

# **ENERGY CONSERVATION AND MANAGEMENT CHAPTER NOTES**



**COMPILED BY  
MR. ANIL KUMAR MANDAL  
DAIRY TECHNOLOGIST VKIDFT  
MANNUTHY KERALA  
(KVASU)**

**Compiled By**  
**Mr. Anil Kumar Mandal**

**Dairy Technologist**  
**VKIDFT Mannuthy Kerala**

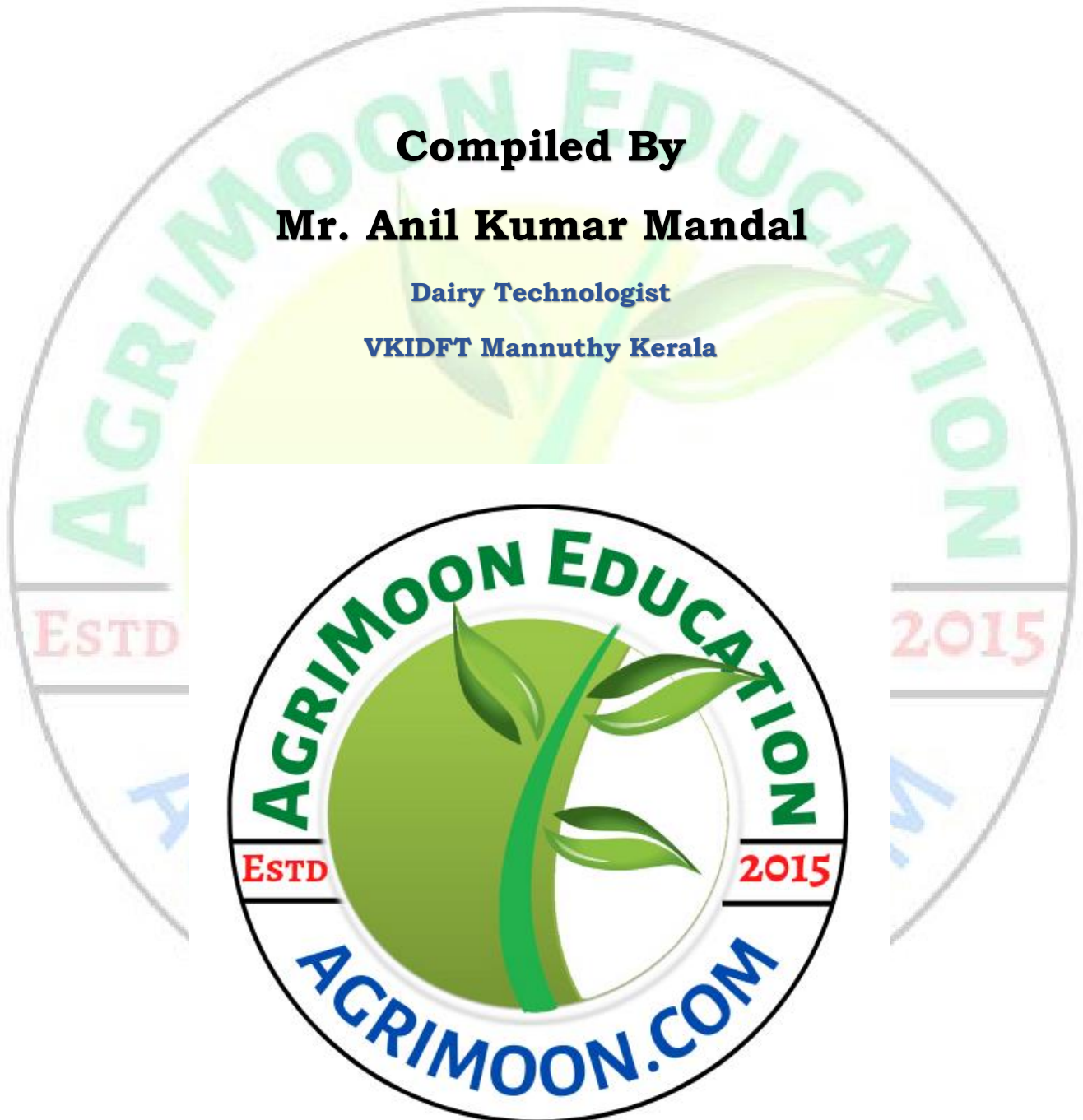



## Index

SN.	Title	Page No.
Lesson 1	Introduction, classification, Present and Past Scenario of Primary Energy Resources in The World, Environmental Aspects Associated with energy utilization	5-10
Lesson 2	Potential and opportunities of industrial energy conservation in dairy and food processing. Energy conservation Act 2001 and its important features, Schemes of Bureau of Energy, Efficiency (BEE). Electricity Act 2003, Integrated energy policy, Electrical load management, Demand management, energy management information systems.	11-21
Lesson 3	Energy management & audit, Definition, energy audit, need, types of energy audit, Energy audit approach-understanding energy costs, bench marking, energy performance, matching energy use to requirement, maximizing system efficiencies, optimizing the input energy requirements, fuel and energy substitution, Energy balances and computation of efficiencies of equipment, instruments and metering for Energy audit.	22-35
Lesson 4	Energy conservation in Refrigeration and AC systems (HVAC), Cooling towers, Pumps and pumping systems, Fans, Blowers, Air compressors, Maintenance and upkeep of Vacuum lines and Compressed air pipe lines, Conservation and reuse of water, water auditing, Energy conservation opportunities in Wastewater treatment.	36-60
Lesson 5	Electrical system, Electrical Billing, Transformers, losses in transformers, Energy savings in transformers Quality of power, Power factor and its improvement, saving controllers and cost saving techniques.	61-69
Lesson 6	Electric motor-selection and application, Energy efficient motors. Variable Speed Drives and Variable Frequency Drives (VFD) and their role in saving electric energy, Industrial Lighting: Quality of light, types of light sources, energy efficiency, Light controls.	70-84
Lesson 7	Energy efficiency and conservation in utilities: High efficiency boilers, improved combustion techniques for energy conservation, Fluidized Bed Combustion and multi fuel capabilities. Application of recuperator to recover energy from flue gases from boiler, DG exhaust, hot air from spray dryer, FBD etc.	85-94
Lesson 8	Energy conservation in steam distribution systems, Thermic fluid heater, efficient piping layouts, protective & insulation coverings in utility pipes, Steam conservation opportunities, Upkeep and maintenance of steam auxiliaries and fittings.	95-100
Lesson 9	Improving efficiency and energy conservation opportunities of thermal processes, improving efficiency and energy conservation opportunities of freezing, improving efficiency and energy conservation in evaporation, Improving Efficiency and Energy Conservation Opportunities in Food Drying. Role of steam traps in energy saving. Energy Savings methods in hot air generator, Steam radiator.	101-122
Lesson 10	Energy conservation in buildings: Concepts of "Green Buildings". Waste-heat recovery and thermal energy storage in food processing facilities, Condensate recovery and reuse.	123-129
Lesson 11	Cleaner energy sources: Introduction to Solar, and Bio-mass Energy; Solar thermal and photo-voltaic energy options for food processing	130-143

**ENERGY CONSERVATION AND MANAGEMENT**

	industries, Carbon credits and carbon trade: Concepts of CDM, economic and societal benefits.	
Lesson 12	Fuel and Oil Conservation, Diesel generating sets, Thermal energy storage and its application, Recuperators Generators, thermocompressor PCM encapsulation.	144-157
Lesson 13	Role of automation in conservation of energy in dairy and food processing: Incorporation of enhanced PLC based computer controls and SCADA.	158-162



## Lesson 1

### Introduction, classification, Present and Past Scenario of Primary Energy Resources in The World, Environmental Aspects Associated with energy utilization

#### Introduction

Energy is one of the major inputs for the economic development of any country. In the case of the developing countries, the energy sector assumes a critical importance in view of the ever-increasing energy needs requiring huge investments to meet them.

Energy is the ability to do work and work is the transfer of energy from one form to another. In practical terms, energy is what we use to manipulate the world around us, whether by exciting our muscles, by using electricity, or by using mechanical devices such as automobiles. Energy comes in different forms - heat (thermal), light (radiant), mechanical, electrical, chemical, and nuclear energy.

**Energy can be classified into several types based on the following criteria:**

1. Primary and Secondary energy
2. Commercial and Non-commercial energy
3. Renewable and Non-Renewable energy

#### 1. Primary and Secondary Energy

Primary energy sources are those that are either found or stored in nature. Common primary energy sources are coal, oil, natural gas, and biomass (such as wood). Other primary energy sources available include nuclear energy from radioactive substances, thermal energy stored in earth's interior, and potential energy due to earth's gravity. The major primary and secondary energy sources are shown in Figure

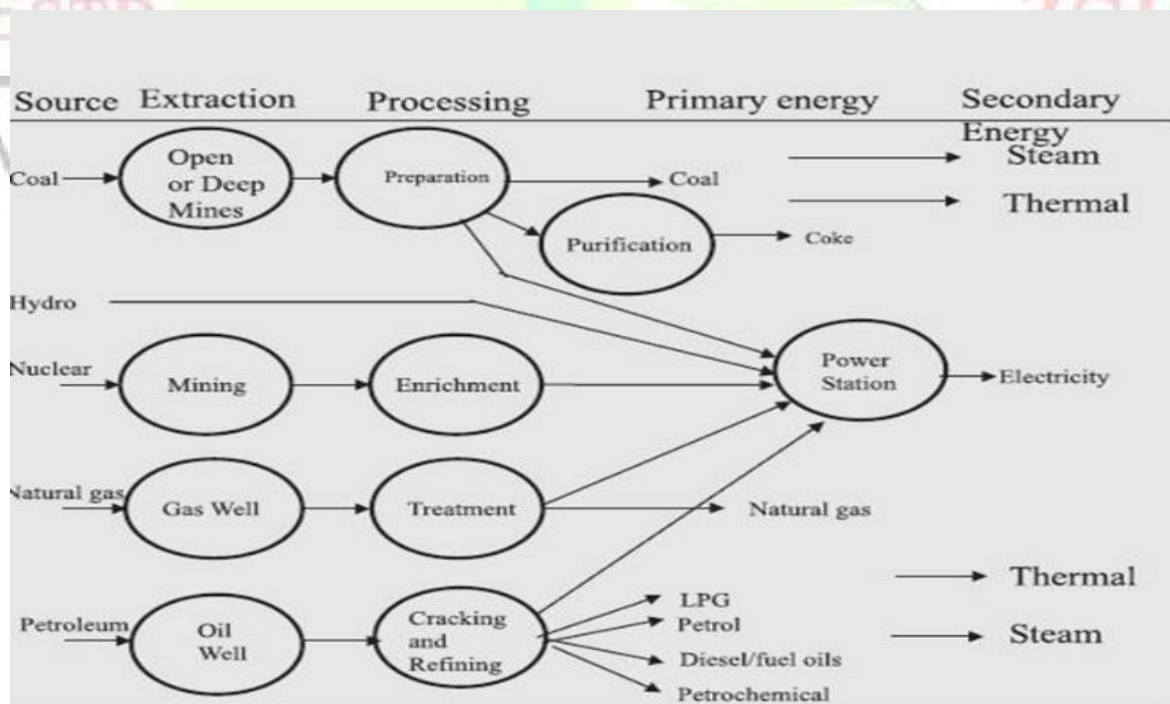

Figure 1.1 Major Primary and Secondary Sources



**2. Commercial Energy and Non-Commercial Energy**

**Commercial Energy**

The energy sources that are available in the market for a definite price are known as commercial energy. By far the most important forms of commercial energy are electricity, coal and refined petroleum products. Commercial energy forms the basis of industrial, agricultural, transport and commercial development in the modern world. In the industrialized countries, commercialized fuels are predominant source not only for economic production, but also for many household tasks of general population.

Examples: Electricity, lignite, coal, oil, natural gas etc.

**Non-Commercial Energy**

The energy sources that are not available in the commercial market for a price are classified as non-commercial energy. Non-commercial energy sources include fuels such as firewood, cattle dung and agricultural wastes, which are traditionally gathered, and not bought at a price used especially in rural households. These are also called traditional fuels. Non-commercial energy is often ignored in energy accounting.

Example: Firewood, agro waste in rural areas; solar energy for water heating, electricity generation, for drying grain, fish and fruits; animal power for transport, threshing, lifting water for irrigation, crushing sugarcane; wind energy for lifting water and electricity generation.

**3. Renewable and Non-Renewable Energy**

Renewable energy is energy obtained from sources that are essentially inexhaustible. Examples of renewable resources include wind power, solar power, geothermal energy, tidal power and hydroelectric power (See Figure 1.2). The most important feature of renewable energy is that it can be harnessed without the release of harmful pollutants.

Non-renewable energy is the conventional fossil fuels such as coal, oil and gas, which are likely to deplete with time.

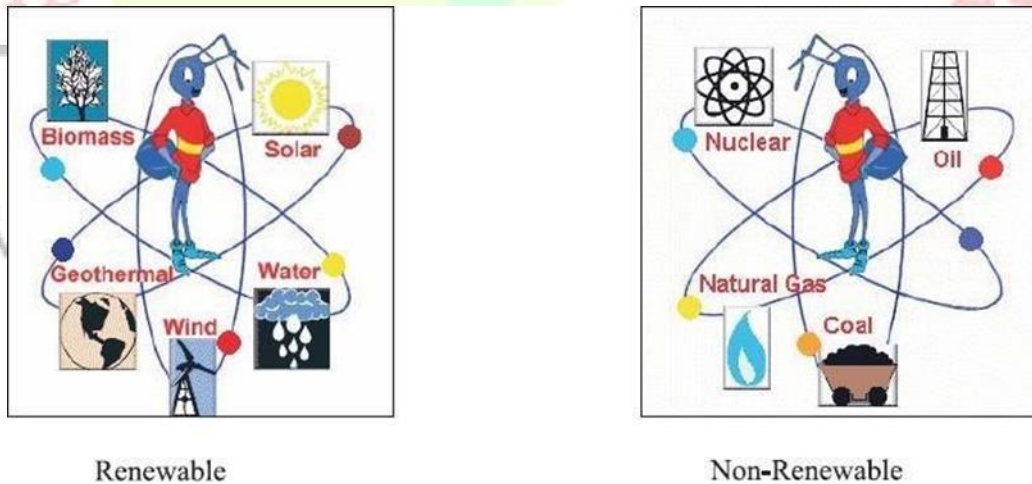

Figure 1.2 Renewable and Non-Renewable Energy

**Energy and Power**

**1. Energy**

Energy is the ability to do a work. Its unit is Joule (J)

$\text{Energy} = \text{force} * \text{Distance}$
--

### 2. Power

Power is defined as the rate of doing work. Its unit is watt (W)

#### 4. Relation Between Energy and Power

$$\text{Energy} = \text{Power} * \text{Time}$$

Example 1

A portable machine requires a force of 200N to move it. How much work is done if the machine is moved 20m and what average power is utilized if the movement takes 25s?

Solution

Work done = force \* distance

$$= 200\text{N} * 20\text{m}$$

$$= 4000 \text{ Nm or } 4 \text{ kJ}$$

$$\text{Power} = \text{work done} / \text{time taken} = 4000 \text{ J} / 25 \text{ s} = 160 \text{ J/s} = 160 \text{ W}$$

#### Present and Past Scenario of Primary Energy Resources in The World

##### 1. Coal

Coal is the most abundant fossil fuel in the world. Coal reserves are available in almost every country in the world. The largest coal reserves are available in the USA followed by Russia, China, Australia and India. The global coal reserve was estimated to be 891.531 billion tones by the end of 2013. But by the end of 2003, it was estimated to be 984.453 billion tones.

##### 2. Crude Oil

The global proven crude oil reserve was estimated to be 1687 billion barrels by the end of 2013. But by the end of 2003, it was estimated to be 1147 billion barrels. Almost 48% of proven oil reserves are in the Middle East countries. Saudi Arabia has the largest share of the reserve with 15.8% followed by Russia and USA.

##### 3. Natural Gas

Natural gas is a gaseous fossil fuel consisting primarily of methane but also includes small quantities of ethane, propane, butane and pentane. Before natural gas can be used as a fuel, it undergoes extensive processing for removing almost all constituents except methane. Natural gas resources are large but they are highly concentrated in few countries. Iran has largest share (18.2%) followed by Russia (16.8%) and Qatar (13.3%). India has only about 0.7% of global natural reserves. The global proven natural gas reserve was estimated to be 176 trillion cubic meters by the end of 2003. But by the end of 2013, it was estimated to be 186 trillion cubic meters.

##### 4. National Energy Consumption Data

The primary energy consumption of some of the countries are given in table. It is seen that India's primary energy consumption is only 4.7% of the world (USA-18%, China-22%).



## ENERGY CONSERVATION AND MANAGEMENT

Country	Million tonnes of oil equivalent ( Mtoe )							% of Share
	Oil	Natural gas	Coal	Nuclear Energy	Hydro-Power	Renewable Energy	Total	
China	507.4	145.5	1925.3	25	206.3	42.9	2852.4	22.4
US	831.0	671.0	455.7	187.9	61.5	58.6	2265.8	17.8
Russia	153.1	372.1	93.5	39.1	41	0.1	699	5.5
India	175.2	46.3	324.3	7.5	29.8	11.7	595.0	4.7
Japan	208.9	105.2	128.6	3.3	18.6	9.4	474.0	3.7
Germany	112.1	75.3	81.3	22.0	4.6	29.7	325.0	2.6
Others	2197.4	1198.3	818	278.4	494	126.9	5519.2	43.3
<b>World</b>	<b>4185.1</b>	<b>3030.4</b>	<b>3826.7</b>	<b>563.2</b>	<b>855.8</b>	<b>279.3</b>	<b>12730.4</b>	<b>100</b>

Source: BP Statistical Review of World Energy, June 2014

### Environmental Aspects Associated with energy utilization

The usage of energy resources in industry leads to environmental damages by polluting the atmosphere. Few of examples of air pollution are sulphur dioxide (SO<sub>2</sub>), nitrous oxide (NO<sub>x</sub>) and carbon monoxide (CO) emissions from boilers and furnaces, chloro-fluro carbons (CFC) emissions from refrigerants use, etc. In chemical and fertilizers industries, toxic gases are released. Cement plants and power plants spew out particulate matter.

#### 1. Air Pollution

In both developed and rapidly industrializing countries, the major historic air pollution problem has typically been high levels of smoke and SO<sub>2</sub> arising from the combustion of sulphur-containing fossil fuels such as coal for domestic and industrial purposes.

In both developed and developing countries, the major threat to clean air is now posed by traffic emissions. Petrol- and diesel-engine motor vehicles emit a wide variety of pollutants, principally carbon monoxide (CO), oxides of nitrogen (NO<sub>x</sub>), volatile organic compounds (VOCs) and particulates, which have an increasing impact on urban air quality.

In addition, photochemical reactions resulting from the action of sunlight on NO<sub>2</sub> and VOCs from vehicles leads to the formation of ozone, a secondary long-range pollutant, which impacts in rural areas often far from the original emission site. Acid rain is another long-range pollutant influenced by vehicle NO<sub>x</sub> emissions.

The principle pollutants produced by industrial, domestic and traffic sources are sulphur dioxide, nitrogen oxides, particulate matter, carbon monoxide, ozone, hydrocarbons, benzene, 1,3-butadiene, toxic organic micro pollutants, lead and heavy metals

#### 2. Climate Change

Human activities, particularly the combustion of fossil fuels, have made the blanket of greenhouse gases (water vapour, carbon dioxide, methane, ozone etc.) around the earth thicker. The resulting increase in global temperature is altering the complex web of systems that allow life to thrive on earth such as rainfall, wind patterns, ocean currents and distribution of plant and animal species.

#### 3. Greenhouse Effect and Carbon Cycle

Life on earth is made possible by energy from the sun, which arrives mainly in the form of visible light. About 30 percent of the sunlight is scattered back into space by outer atmosphere and the balance 70 percent reaches the earth's surface, which reflects it in form of infrared radiation. The



## ENERGY CONSERVATION AND MANAGEMENT

escape of slow-moving infrared radiation is delayed by the greenhouse gases. A thicker blanket of greenhouse gases traps more infrared radiation and increase the earth's temperature

Carbon dioxide is responsible for 60 percent of the "enhanced greenhouse effect". Humans are burning coal, oil and natural gas at a rate that is much faster than the rate at which these fossil fuels were created. This is releasing the carbon stored in the fuels into the atmosphere and upsetting the carbon cycle (a precise balanced system by which carbon is exchanged between the air, the oceans and land vegetation taking place over millions of years). Currently, carbon dioxide levels in the atmospheric are rising by over 10 percent every 20 years.

**The effects of increase in the earth's temperature are as follows:**

4. Severe Storms and Flooding
5. Food Shortages
6. Reduced Freshwater supply
7. Loss of Biodiversity
8. Increased Diseases

### 4. Acid Rain

Acid rain is caused by release of SOX and NOX from combustion of fossil fuels, which then mix with water vapour in atmosphere to form sulphuric and nitric acids respectively.

**The effects of acid rain are as follows:**

9. Acidification of lakes, streams, and soils
10. Direct and indirect effects (release of metals, for example: Aluminium which washes away plant nutrients)
11. Killing of wildlife (trees, crops, aquatic plants, and animals)
12. Decay of building materials and paints, statues, and sculptures
13. Health problems (respiratory, burning- skin and eyes)

### Energy Conservation and its Importance

Coal and other fossil fuels, have taken hundreds of millions of years to form, are likely to deplete soon. In the last two hundred years, we have consumed 60% of all resources. For sustainable development, we need to adopt energy efficiency measures. Today, 85% of India's primary energy comes from non-renewable and fossil sources (coal, oil, etc.). These reserves are continually diminishing with increasing consumption and will not exist for future generations (see Figure).

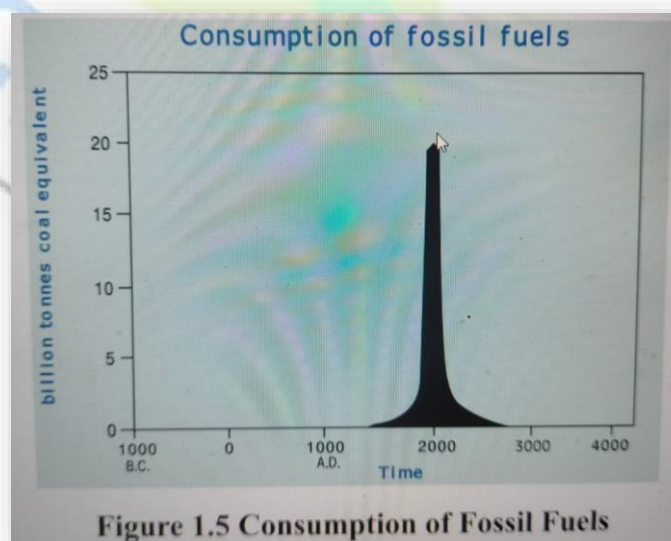

Figure 1.5 Consumption of Fossil Fuels

**What is Energy Conservation?**

Energy Conservation and Energy Efficiency are separate, but related concepts. Energy conservation is achieved when growth of energy consumption is reduced in physical terms. Energy Conservation can, therefore, be the result of several processes or developments, such as productivity increase or technological progress. On the other hand, Energy efficiency is achieved when energy intensity in a specific product, process or area of production or consumption is reduced without affecting output, consumption or comfort levels. Promotion of energy efficiency will contribute to energy conservation and is therefore an integral part of energy conservation promotional policies.

Energy efficiency is often viewed as a resource option like coal, oil or natural gas. It provides additional economic value by preserving the resource base and reducing pollution. For example, replacing Incandescent lamps with LED's means will require 1/8th of the energy to light a room. Pollution levels also reduce by the same amount

(see fig.)

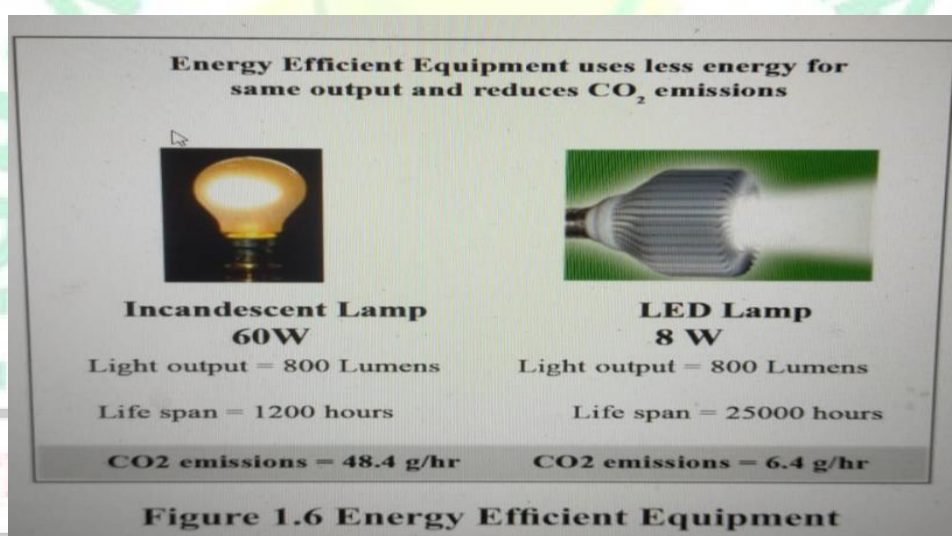

## Lesson 2

**Potential and opportunities of industrial energy conservation in dairy and food processing. Energy conservation Act 2001 and its important features, Schemes of Bureau of Energy, Efficiency (BEE). Electricity Act 2003, Integrated energy policy, Electrical load management, Demand management, energy management information systems.**

### **Introduction to industrial energy conservation in dairy and food Processing**

- Dairy industry is of crucial importance to India.
- The country is the world's largest milk producer, accounting for more than 13% of world's total milk production.
- It is the world's largest consumer of dairy products, consuming almost 100% of its own milk production.
- Dairy products are a major source of cheap and nutritious food to millions of people in India.
- The dairy sector in the India has shown remarkable development in the past decade and India has now become one of the largest producers of milk and value-added milk products in the world.
- The dairy sector has developed through co-operatives in many parts of the States in India.
- Dairy industries always have been energy intensive industries.
- In the course of their activities, companies use electrical energy to drive cooling systems, pumps, fans, compressed air systems and lighting and one or more types of fuel to burn in combustion plants (boilers), for water heating or for steam production (cleaning operations or production processes).
- The increase of people in the major population centers as well as the need to provide food of good quality, in good health and safety condition, makes the supply chain more energy demanding, especially on the refrigeration systems.
- These refrigeration systems are referenced in the food industry as major consumers of energy due to the high number of used systems and required refrigeration power.
- Several studies conducted on this sector, point out that the high consumption of electricity is due to refrigeration systems.
- Sometimes simple energy efficiency measures and good maintenance of the facilities, could help to reduce the energy consumption by 15%.
- The energy audit has been conducted at dairy; it includes chiller, boiler, air compressor and miscellaneous issues.
- Techno economic analysis of boiler, air compressor, chiller and miscellaneous issues has been done.

Major activities in the BEE-SME program are furnished below:

#### **Activity 1: Energy use and technology audit**

- The energy use technology studies would provide information on technology status, best operating practices, gaps in skills and knowledge on energy conservation opportunities, energy saving potential and new energy efficient technologies, etc for each of the sub sector in SMEs.



## ENERGY CONSERVATION AND MANAGEMENT

### Activity 2: Capacity building of stake holders in cluster on energy

#### efficiency

- In most of the cases SME entrepreneurs are dependent on the locally available technologies, service providers for various reasons.
- To address this issue BEE has also undertaken capacity building of local service providers and entrepreneurs/Managers of SMEs on energy efficiency improvement in their units as well as clusters.
- The local service providers will be trained in order to be able to provide the local services in setting up of energy efficient projects in the clusters.

### Activity 3: Implementation of energy efficiency measures

- To implement the technology up-gradation project in the clusters, BEE has proposed to prepare the technology based detailed project reports (DPRs) for a minimum of five technologies in three capacities for each technology.

### Activity 4: Facilitation of innovative financing mechanisms for implementation of energy efficient projects

- The objective of this activity is to facilitate the uptake of energy efficient measures through innovative financing mechanisms without creating market distortion.

## ENERGY CONSERVATION ACT-2001

### Introduction

Energy Conservation Act (EC Act) was enacted by the Government of India in 2001 to provide legal framework and institutional arrangements for enhancing energy efficiency. This Act led to the creation of Bureau of Energy Efficiency (BEE) as the nodal agency at the center and State Designated Agencies (SDAs) at the State level to implement the provisions of the Act. The Central Government, State Government and Bureau of Energy Efficiency have major roles to play in implementation of the Act. The Mission of BEE is to develop policy and strategies based on self-regulation and market principles with the goal of reducing energy intensity of the Indian economy. This will be achieved with active participation of all stakeholders, resulting in rapid and sustained adoption of energy efficiency in all sectors.

### Salient Features of the Energy Conservation Act, 2001 (Amended in 2010)

The Act empowers the Central and State Governments to facilitate and enforce efficient use of energy and its conservation, notify energy-intensive industries, establishments and commercial buildings as designated consumers and prescribe energy consumption norms and standards for designated consumers. The Act was amended in 2010.

The Amendment expanded the scope of energy conservation norms for buildings and tightened the applicability of energy efficiency norms for appliances and equipment. It provided a framework within which savings on energy use can be traded between those industries who are energy efficient and those whose consumption of energy is more than the maximum set by the government. The amendment increased penalties for non-compliance and provided for establishment of appellate tribunal for energy conservation to hear appeals against the orders of the adjudicating officer or the Central Government or the State Government or any other authority under the Energy Conservation Act.

The excerpts of relevant sections of Energy Conservation Act are reproduced below for the benefit of Energy Managers and Energy Auditors. However, the full text of the act is available in BEE website

## ENERGY CONSERVATION AND MANAGEMENT

### Key Definitions as Outlined in the Act

**Building:** "building" means any structure or erection or part of structure or erection after the rules relating to energy conservation building codes have been notified (under clause (p) of section 14 and clause (a) of section 15) and includes any existing structure or erection or part of structure of erection, which is having a connected load of 100 Kilowatt (kW) or contract demand of 120 Kilo-volt Ampere (KVA) and above and is used or intended to be used for commercial purposes.

**Designated agency:** Designated agency means an agency which coordinates, regulates and enforces provisions of this act within a State.

**Designated consumer:** Designated consumer means any user or class of users of energy in a energy intensive industries and other establishments specified in the Schedule as designated consumer.

**Energy:** Energy means any form of energy derived from fossil fuels, nuclear substances or materials, hydro-electricity and includes electrical energy or electricity generated from renewable sources of energy or biomass connected to the grid.

**Energy audit:** Energy audit means the verification, monitoring and analyses of use of energy including submission of technical report containing recommendations for improving energy efficiency with cost benefit analysis and an action plan to reduce energy consumption

**Energy conservation building codes:** It means the norms and standards of energy consumption expressed in terms of per square meter of the area and wherein energy is used and includes location of the building

**Energy consumption standards:** It means norms for process and energy consumption standards (specified under clause (a) of section 14).

Energy savings certificate: "Energy savings certificate" means any energy savings certificate issued to the designated consumers (under sub-section (1) of section 14A).

Equipment or appliance: It means any equipment or appliance which consumes, generates, transmits or supplies energy and includes any device that consumes any form of energy and produces in desired work.

## CHAPTER IV of EC Act

### 1. Powers and Functions of Bureau

13. (1) The Bureau shall, effectively co-ordinate with designated consumers, designated agencies and other agencies, recognize and utilise the existing resources and infrastructure, in performing the functions assigned to it by or under this Act.

(2) The Bureau may perform such functions and exercise such powers as may be assigned to it by or under this Act and in particular, such functions and powers include the function and power to -

(a) recommend to the Central Government the norms for processes and energy consumption standards required to be notified under section 14A;

(aa) recommend to the Central Government for issuing of the energy savings certificate

## CHAPTER V of EC Act

### 2. Power of Central Government to Facilitate and Enforce Efficient Use of Energy and its Conservation

Central Government may, by notification, in consultation with the Bureau, -



## **ENERGY CONSERVATION AND MANAGEMENT**

(a) specify the norms for processes and energy consumption standards for any equipment, appliances which consumes, generates, transmits or supplies energy

(b) specify equipment or appliance or class of equipment's or appliances, as the case may be, for the purposes of this Act;

(c) prohibit manufacture or sale or purchase or import of equipment or appliance specified under clause(b) unless such equipment or appliances conforms to energy consumption standards;

Provided that no notification prohibiting manufacture or sale or purchase or import or equipment or appliance shall be issued within a period of six months from the date of notification;

Provided further that the Central Government may, having regard to the market share and the technological development having impact on equipment or appliance, and for reasons to be recorded in writing, extend the said period of six months referred to in the first proviso by a further period not exceeding six months;

## **CHAPTER VI of EC ACT**

### **3. Power of State Government to facilitate and Enforce Efficient Use of Energy and its Conservation**

The State Government may, by notification, in consultation with the Bureau -

(a) amend the energy conservation building codes to suit the regional and local climatic conditions and may, by rules made by it, specify and notify energy conservation building codes with respect to use of energy in the buildings;

(b) direct every owner or occupier of a building or building complex being a designated consumer to comply with the provisions of the energy conservation building codes,

### **Establishment of Fund by State Government**

(1) The State Government shall constitute a Fund to be called the State Energy Conservation Fund for the purposes of promotion of efficient use of energy and its conservation within the State.

(2) To the Fund shall be credited all grants and loans that may be made by the State Government or, Central Government or any other organization or individual for the purposes of this Act.

(3) The Fund shall be applied for meeting the expenses incurred for implementing the provisions of this Act.

(4) The Fund created shall be administered by such persons or any authority and in such manner as may be specified in the rules made by the State Government.

## **CHAPTER VIII of EC Act**

### **PENALTIES AND ADJUDICATION**

#### **Penalty**

(1) If any person fails to comply with the provisions of clause (c) or clause (d) or clause (h) or clause (i) or clause (k) or clause (1) [xxx] or clause (r) or clause (s) of section 14 or clause (b) or clause (c) or clause (h) of section 15, he shall be liable to a penalty which shall not exceed ten lakh rupees for each such failure and, in the case of continuing failure, with an additional penalty which may extend to ten thousand rupees for every day during which such failure continues:

PROVIDED that no person shall be liable to pay penalty within five years from the date of commencement of this Act.

(1A) If any person fails to comply with the provisions of clause (n) of section 14, he shall be liable to a penalty which shall not exceed ten lakh rupees and, in the case of continuing failure, with an



## **ENERGY CONSERVATION AND MANAGEMENT**

additional penalty which shall not be less than the price of every metric ton of oil equivalent of energy, prescribed under this Act, that is in excess of the prescribed norms.

(2) Any amount payable under this section, if not paid, may be recovered as if it were an arrear of land revenue.

### **Role of State Designated Agencies**

As per Energy Conservation Act 2001, State Governments have been empowered to designate agencies (State Designated Agency, ie. SDA) in consultation with Bureau of Energy Efficiency. Designated Agencies will have the responsibility to implement the Act within the State.

### **Responsibilities**

- Spread awareness on EC Act
- Undertake voluntary initiatives to promote energy conservation.
- Liaison and coordinate with BEE, State Government Departments dealing with energy, industry, planning, regulators, consumer affairs, municipal bodies etc.
- Capacity building of staff employed
- Launch and maintain state specific website addressing the voluntary and mandatory provisions of EC Act
- Undertake energy conservation awareness program for consumers, industrial & commercial sector, school children, farmers etc.
- Arrange interactive meets between energy managers, energy auditors, designated consumers and other, experts

### **Duties**

- Prepare a list of designated consumers
- Compile information received from designated consumers through annual statements on energy consumption, energy audit reports, and action taken on the report of energy audit
- Prepare a state and sectoral energy data base and provide the feedback to designated consumers
- Take all measures necessary to create awareness and disseminate information for efficient use of energy and its conservation
- Arrange and organize training of personnel and specialists in the techniques for efficient use of energy and its conservation
- Take steps to encourage preferential treatment for use of energy efficient equipment or appliances
- Appoint or designate inspecting officer with specified powers as necessary for the purpose of ensuring compliance with energy consumption standards
- Assist State Government in the preparation of Rules under Section 57 of the Energy Conservation Act.
- Establish Energy Conservation Fund for the purposes of promotion of efficient use of energy and its conservation within the State.

### **Schemes of BEE under the Energy Conservation Act-2001**

- Energy Conservation Building Codes (ECBC)
- Standards and Labelling (S & L)
- Demand Side Management (DSM)
- Bachat Lamp Yojana (BLY)
- Promoting Energy Efficiency in Small and Medium Enterprises (SMEs)
- Designated Consumers
- Certification of energy auditors and energy managers

## ENERGY CONSERVATION AND MANAGEMENT

### Electricity Act, 2003

The government has enacted Electricity Act, 2003 which seeks to transform and develop the electricity sector by distancing Government from the task of regulation.

Before enactment of this act, electricity supply in India was governed by Indian Electricity Act, 1910, the Electricity (Supply) Act, 1948 and the Electricity Regulatory Commissions Act, 1998. There was a need to consolidate the provisions of above act and consequently, Electricity Act was introduced in 2003.

#### The objectives of the Act are

- To consolidate the laws relating to generation, transmission, distribution, trading and use of electricity
- To take measures suitable for development of electricity industry
- To promote competition
- To protect interest of consumers and supply of electricity to all areas,
- To ensure transparent policies regarding subsidies
- To promote efficient and environmentally benign policies
- To constitute Central Electricity Authority (CEA), Regulatory Commissions

#### Main features of Electricity Act 2003

- Generation free from licensing
- Captive generation free from control
- Re-structuring of State Electricity Boards
- Mandatory establishment of Regulatory Commissions
- Open access in transmission
- Open access in distribution to be allowed by State Regulators in phased manner
- Recognition of electricity trading as a distinct activity
- Stringent provisions for violation of grid discipline and theft of power
- Supply of electricity to all areas and specific provisions for supply in rural areas
- Rationalization of electricity tariff

#### Role of Government

Central Government will prepare National Electricity Policy and Tariff Policy, focus on rural areas permitting stand-alone systems and non-conventional energy in consultation with States, bulk purchase of power and distribution through Panchayats, Cooperative Societies, non-Government organisations, franchisees etc. The constitution of State Regulatory commission is a mandatory requirement. If subsidy is provided by Central State Government, provision has to be created in the budget.

#### Rural Electrification

Goal of Government is to extend supply of electricity to all village's hamlets. No licence is required for generation and distribution in rural area.

#### Generation

Generation is freed from licensing. Captive Generation is free from controls. Open access is allowed to Captive generating plants subject to availability of transmission facility. However, clearance of CEA for hydro projects is required due to concern of dam safety and inter-State issues. Generation from Non-Conventional Sources/Co-generation will be promoted. Minimum percentage of purchase of power from renewable energy sources may be prescribed by Regulatory Commissions.



## ENERGY CONSERVATION AND MANAGEMENT

### Transmission

- Transmission Utility at the Central as well as State level, to be a Government company with responsibility for planned and coordinated development of transmission network.
- The transmission of electricity is handled by Central and State Transmission utilities (CTU and STU), which have 51% Government equity.
- CTU and STUs will only be carriers and not engage in trading

However, load despatch would be under control of Government as it is critical for grid stability and neutrality. Open access to the transmission lines would be provided to distribution licensees, generating companies. This would promote competitions and lead to gradual cost reduction, Private licensees.

### Distribution

Distribution would be licensed. Distribution licensees would be free to undertake generation and generating companies would be allowed to take up distribution businesses. Open access in distribution would be introduced in phases. Retail tariff would be determined by Regulatory commission. Metering of all electricity supplied would be made mandatory, Private licensees would be allowed in distribution.

### Renewable energy

A significant regulatory impact on renewable energy was made by the Electricity Act, 2003, which provides for the determination of quotas or Renewable Purchase Obligation (RPO) by the State Electricity Regulatory Commissions (SERC). Internationally, this is commonly referred to as the Renewable Portfolio Standard (RPS) The RPS is a policy instrument that ensures that a minimum amount of renewable energy is included in the portfolio of resources

The policy obligates each retail seller of electricity to include in its resource portfolio a certain proportion of power from renewable energy resources, such as wind, solar, small hydro and various forms of biomass energy. The retailer can satisfy this obligation by both owning a renewable energy facility and producing own power or purchasing power from someone's facility.

### Consumer

- Consumer to be given connection within stipulated time
- Penalty in case of failure to give connection
- Ombudsman scheme for consumers grievance redressal
- Regulatory commission to specify Electricity supply code to be followed by licensees

### Integrated Energy Policy

- India's integrated Energy Policy, released in August 2006, is a comprehensive policy on Energy which is drafted to explore alternative technologies and possible synergies that would increase energy system efficiency and meet requirement for energy services.
- The Integrated Energy Policy addresses all aspects of energy, including energy security, access and availability, affordability and pricing, efficiency and the environment.
- The report of the expert committee appointed by the Planning Commission to improve energy efficiency given aims and objectives of India's Integrated Energy Policy.
- The broad vision behind the energy policy is to provide safe and convenient energy at the lowest cost in a technically efficient, economically viable, and environmentally sustainable manner -thereby reliably meeting the demand for energy services of all sectors, including the energy needs of vulnerable households in all parts of the country.

#### **On energy efficiency, the IEP proposes a number of goals:**

- Reduce energy intensity by 20%
- Increase average gross efficiency of power generation from 30.5% to 34%.





### Recommendations of the expert committee

The report of the expert committee appointed by the Planning Commission to improve energy efficiency itself contains the following key recommendations:

1. Coal will remain a primary energy source until 2031-32.
2. Rationalize fuel prices through the Integrated Energy Policy. Promote efficient fuel choices and facilitate substitution.
3. Improve energy efficiency, reduce energy intensity.
4. Augment fossil fuel resources by increased exploration for coal, oil and natural gas.
5. Augment the role of hydro and nuclear power in India.
6. Push for increased renewable
7. Energy in the energy mix

### Aims and Objectives of Integrated Energy Policy

1. Provide appropriate fiscal policies to take care of externalities, independent regulations to address anti-competitive market behavior.
2. Tax and regulatory structures should provide a level playing field for all sectors and all players
3. Taxes should be neutral except in cases specifically intended to counter externalities such as environmental costs
4. Transparent and targeted subsidies
5. Promoting energy efficiency by enforcing standards effectively
6. Promote competitive energy markets in order to promote energy efficiency and leverage investment in the energy sector. Remove entry barriers to new players and imports.
7. Correct pricing of energy, in order to send the right signals to producers and consumers.
8. Incentive for renewable energy production to be linked to output and not just capacity addition (outlay).

### Electric load management

- Electric load management, which is often called simply load management, refers to the systems that match electricity supplies with demand.
- A steady supply of power is generally quite straightforward to produce with a typical coal, gas or nuclear plant - simplifier up the generator and make sure you have a steady supply of fuel.

## ENERGY CONSERVATION AND MANAGEMENT

- However, the demand is not steady: there is more demand during sometimes.
- A power company must be able to supply power at all times.
- The means by which they do this are collectively called load management.
- Load management generally falls into one of three categories: load clipping, load shifting, and valley filling, which are shown in Fig below.

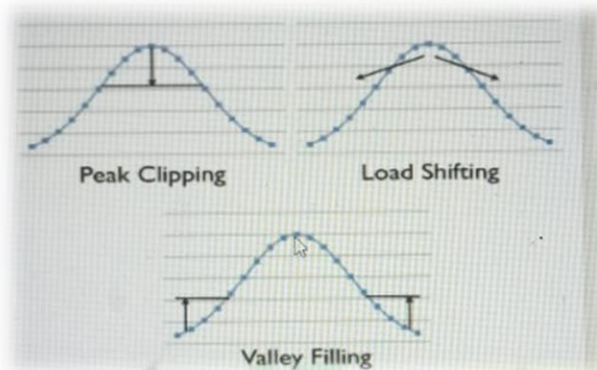

- Most of the strategies described here are load clipping or load shifting strategies.
- This usually means raising energy prices during peak usage times and on high-volume users. Raising rates during peak hours is possible because peak usage is quite predictable, with modern predictions typically within 1%.
- Power companies also sometimes have programs in place in which equipment like water heaters are put under the direct control of the utility, to turn off during particularly high peak times.

## Energy Demand Management

- One of the main goals of energy demand management is convincing customers to reduce energy consumption during peak demand hours or changing energy usage habits to allocate high-energy device use during off-peak periods such as weekends or during late nights.
- While managing consumption and energy usage habits during peak hours may not necessarily decrease overall energy consumption, but it reduces investments in network hardware and power-plant equipment.
- Modern developments in energy demand management have allowed grid operators to coincide renewable energy generation with peak-demand hours.
- Energy usage varies significantly during a day.
- There are peak demand hours and periods of time when demand is really low.
- In order to optimize and improve the process of energy generation and transmission, predicting and planning for such demand fluctuations is vital.
- Things become even more critical when there are changes in demand within short periods of time.
- While traditional energy generation sources can adjust to changes in demand, during the peak-demands and sudden rise in demands they fall short in providing the additional power efficiently.
- This instantaneous response to peak demands has serious environmental and financial setbacks as not only do power plants need to ramp-up their operations within a short span of time; also, there is no efficient pricing system for supply during such peak times.
- Energy demand management systems aim to optimize the demand-supply and optimize energy generation and transmission systems.
- Energy demand systems are automated systems that send signals to the customers to shed load depending on systems conditions.

## ENERGY CONSERVATION AND MANAGEMENT

- It also informs the system supervisors about the coming changes in demand patterns.
- This allows grid supervisors to fine-tune the demand to match the available supply.
- During such peak-durations energy demand systems protect the various generation and transmission systems from overloading.
- Adjustments to demands can be made in a variety of ways.
- Some of the popular modes of demand adjustment are responding to price signals, differential pricing for demand hours, introducing changes in behavioural patterns through home area networks, automated devices such as remotely controlled air-conditioning systems or installing permanent solutions such as appliances with high energy efficiency ratings.
- The goal is to demand consumers the accurate price that reflects the value of utility at that point in time.
- Some of the common arguments against energy demand management include high utility costs for consumers and a reduction in profits for energy providers.
- Another issue with energy demand management is privacy. Since consumers need to provide data about their personal energy consumptions, it provides a window into the patterns of their personal lives. However, this privacy issue is being addressed by collecting.

## Energy management information systems

- An energy management information system (EMIS) is a performance management system that enables individuals and organizations to plan, make decisions and take effective actions to manage energy use and costs.
- An EMIS makes energy performance visible to different levels of the organization by converting energy and utility driver data at energy account centers into energy performance information. It does this by using performance equations that are compared with the organization's energy targets.

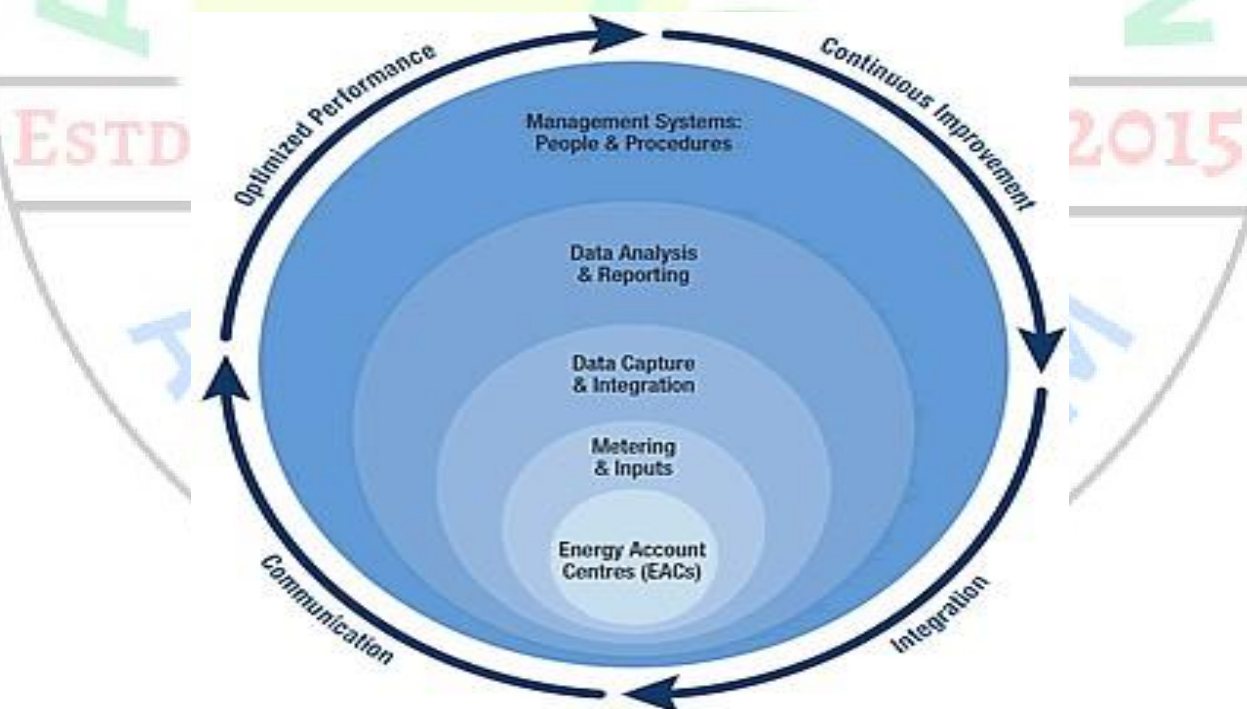

- The EMIS performance management system is illustrated as a continuous cycle of communication, optimised performance, continuous improvement and integration around a core that has Energy Account Centres (EACs) at its centre surrounded by the following consecutive layers:
- Metering & Inputs, Data Capture & Integration, Data Analysis and Reporting, and Management Systems:



## ENERGY CONSERVATION AND MANAGEMENT

- People and Procedures.
- The development of a functioning EMIS system is illustrated in three phases.

### Phase 1: EMIS Audit

- An EMIS audit is an in-depth, eight-step process that will help your organization find out how much energy it is using, identify gaps and make recommendations.
- Critically, it will help you determine whether there is a financial case for implementing EMIS.

### Phase 2: Implementation Plan

- This phase shows you accurate costs for implementing EMIS and details the scope of the project and the resources your organization needs to manage it.
- It also gives you a schedule to implement and manage an EMIS.

### Phase 3: Implementation

- The implementation phase allows your organization to make continuous energy efficiency improvements.
- Once all aspects of your plan are implemented, your EMIS will gather information on energy consumption
  - a) gather information on the useful outputs that result from the consumption of energy
  - b) gather information on any other factors that may affect energy consumption
- contain analysis routines that allow you to compare between energy consumption and utility drivers
- build and display energy performance reports



### Lesson 3

#### Energy Management and Audit

##### Definition and Objectives of Energy Management

The fundamental goal of energy management is to produce goods and provide services with the least cost and least environmental effect. The definition of energy management is:

"The judicious and effective use of energy to maximize profits (minimize costs) and enhance competitive positions" (or)

"The strategy of adjusting and optimizing energy, using systems and procedures so as to reduce energy requirements per unit of output while holding constant or reducing total costs of producing the output from these systems"

##### The objectives of Energy Management include,

- To achieve and maintain optimum energy procurement and utilisation, throughout the organization
- To minimise energy costs/waste without affecting production and quality
- To minimise environmental effects.

Successful energy management must combine an effective strategy with the right practical action. It begins with the key decision makers, and then involves every employee on a day-to-day basis. Many organisations would like to save energy, but to have the most impact and success, they need to give priority to energy management and make it an integral part of company management strategy.

##### Energy Audit Definition

Energy Audit is the key to a systematic approach for decision-making in the area of energy management. It attempts to balance the total energy inputs with its use, and serves to identify all the energy streams in a facility. It quantifies energy usage according to its discrete functions. Industrial Energy Audit is fundamental to a comprehensive energy management programme and is defined in EC Act 2001 as follows:

"Energy Audit" means the verification, monitoring and analysis of use of energy including submission of technical report containing recommendations for improving energy efficiency with cost benefit analysis and an action plan to reduce energy consumption.

##### Objectives of Energy Audit

- To establish the basic relative costs of the various forms of energy and to identify main locations where losses, wastages or inefficiency occurs.
- Identify areas where waste can occur and where scope for improvement.
- It is one of the concepts used in the energy management and it involves methodological examination and comprehensive review of energy use in industries.

##### Energy Auditing

As per the Energy Conservation Act, 2001, Energy Audit is defined as "the verification, monitoring and analysis of use of energy including submission of technical report containing recommendations for improving energy efficiency with cost benefit analysis and an action plan to reduce energy consumption"

##### Need for Energy Audit

. In any industry, the three top operating expenses are often found to be energy (both electrical and thermal), labour and materials. If one were to relate to the manageability of the cost or

## ENERGY CONSERVATION AND MANAGEMENT

potential cost savings in each of the above components, energy would invariably emerge as a top ranker, and thus energy management function constitutes a strategic area for cost reduction. Energy Audit will help to understand more about the ways energy and fuel are used in any industry, and help in identifying the areas where waste can occur and where scope for improvement exists.

The Energy Audit would give a positive orientation to the energy cost reduction, preventive maintenance and quality control programmes which are vital for production and utility activities. Such an audit programme will help to keep focus on variations which occur in the energy costs, availability and reliability of supply of energy, decide on appropriate energy mix, identify energy conservation technologies, retrofit for energy conservation equipment etc.

In general, Energy Audit is the translation of conservation ideas into realities, by lending technically feasible solutions with economic and other organizational considerations within a specified time frame.

The primary objective of Energy Audit is to determine ways to reduce energy consumption per unit of product output or to lower operating costs. Energy Audit provides a "bench-mark" (Reference point) for managing energy in the organization and also provides the basis for planning a more effective use of energy throughout the organization.

### Types of Energy Audit and Approach

The type of energy audit to be performed depends on the type of industry, the depth to which final audit is needed, and the potential and magnitude of cost reduction desired. Thus, energy audit can be classified into the following types: **Preliminary Audit, Targeted Energy Audits and Detailed Audit.**

#### 1. Preliminary Energy Audit

Preliminary energy audit, which is also known as Walk-Through Audit and Diagnostic Audit, is a relatively quick exercise and uses existing, or easily obtained data. The scope of preliminary energy audit is to:

- Establish energy consumption in the organization (sources: energy bills and invoices)
- Obtain related data such as production for relating with energy consumption
- Estimate the scope for energy savings
- Identify the most likely and the easiest areas for attention (e.g. unnecessary lighting, higher temperature settings, leakage etc.)
- Identify immediate (especially no-/low-cost) improvements/ savings
- Set up a baseline or reference point for energy consumption
- Identify areas for more detailed study/measurement Some example of no-cost energy management measures is:
  - Arresting leaks (steam, compressed air)
  - Controlling excess air by adjusting fan damper Some examples of low-cost energy management measures are:
    - Shutting equipment when not needed (e.g. idle running of motors)
    - Replacement with appropriate lamps and luminaires Areas for detailed study/measurement are:
      - Converting from direct to indirect steam heated equipment and recovery of condensate
      - Installing/upgrading insulation on equipment
      - Modifying process to reduce steam demand
      - Investigating scheduling of process operations to reduce peak steam or water demands
      - Evaluating waste heat streams for potential waste heat recovery

#### 2. Targeted Energy Audits



## ENERGY CONSERVATION AND MANAGEMENT

Targeted energy audits often result from preliminary audits. They provide data and detailed analysis on specified target projects. For example, an organization may target its lighting system or boiler system or steam system or compressed air system with a view of effecting energy savings. Targeted audits therefore involve detailed surveys of the target subjects and analysis of the energy flows and cost associated with the targets. Final outcome is the recommendations regarding actions to be taken.

### 3. Detailed Energy Audit

Detailed energy audit is a comprehensive audit and results in a detailed energy project implementation plan for a facility, since it accounts for the energy use of all major equipment. It considers the interactive effects of various projects and offers the most accurate estimate of energy savings and cost. It includes detailed energy cost saving calculations and project implementation costs.

One of the key elements in a detailed energy audit is the energy balance. This is based on an inventory of energy-using systems, assumptions of current operating conditions, measurements and calculations of energy use.

Detailed energy auditing is carried out in three phases: a) Pre-Audit Phase b) Audit Phase and c) Post Audit Phase. A comprehensive ten-step methodology for conducting detailed energy audit is suggested as follows. However, methodology is flexible and can be adapted depending upon the industry concerned.

#### Understanding Energy Costs

- Understanding energy cost is vital factor for awareness creation and saving calculation.
- In many industries sufficient meters may not be available to measure all the energy used.
- In such cases, invoices for fuels and electricity will be useful.
- The annual company balance sheet is the other sources
- where fuel cost and power are given with production related information.
- Energy invoices can be used for the following purposes:
  - They provide a record of energy purchased in a given year, which gives a base-line for future reference?
  - Energy invoices may indicate the potential for savings when related to production requirements or to air conditioning requirements/space heating etc.
  - When electricity is purchased on the basis of maximum
  - demand tariff, they can suggest where savings are most likely
  - to be made.
  - In later years invoices can be used to quantify the energy and
  - cost savings made through energy conservation measures

#### Benchmarking

- Benchmarking can be a useful tool for understanding energy consumption patterns in the industrial sector and also to take requisite measures for improving energy efficiency.

##### Factors Involved:

1. Scale of operation
2. use of technology
3. Raw material specifications and quality
4. Product specifications and quality

#### Benchmarking for Energy Performance

- Internal Benchmarking
- Historical and trend analysis
- External Benchmarking

## ENERGY CONSERVATION AND MANAGEMENT

- Across similar industries
- Scale of operation, use of technology, raw material specification and quality and product specification and quality

### **Bench Marking Energy Performance**

- Quantification of fixed and variable energy consumption trends vis-à-vis production levels
- Comparison of the industry energy performance w.r.t. various production levels (capacity utilization)
- Identification of best practices (based on the external benchmarking data)
- Scope and margin available for energy consumption and cost reduction
- Basis for monitoring and target setting exercises

### **Matching Energy Usage to Requirement:**

- Mismatch between equipment capacity and user requirement often leads to inefficiencies due to part load operations, wastages etc.
- Electrical systems are built to continuously match the supply of electricity to customer demand.
- To meet these changes in demand, the electrical system must have enough capacity to supply energy exactly when it is needed.
- As well, there needs to be enough stored energy to meet upcoming needs for future demand.
- Electricity generation is measured via two related but different measures: energy and capacity.
- Energy is a measure of power used over time and represents the “work” that could be done.
- Capacity is a measure of the ability of a given power source to produce power, typically measured in watts (“W”), kilowatts (“kW”), or megawatts (“MW”).
- The energy is what we consume to do work and capacity is the assurance that the energy we want to use is instantly available when energy is required.

### **Maximising System Efficiency:**

- Once the energy usage and sources are matched properly, the next step is to operate the equipment efficiently through best practices in operation and maintenance as well as judicious technology adoption.

### **Optimising the Input Energy Requirements:**

- Consequent upon fine-tuning the energy use practices, attention is accorded to considerations for minimizing energy input requirements.

#### **The range of measures could include:**

1. Shuffling of compressors to match needs.
2. Periodic review of insulation thickness
3. Identify potential for heat exchanger networking and process integration.
4. Optimisation of transformer operation with respect to load.

### **Fuel and Energy Substitution:**

- Substituting existing fossil fuel with more efficient and less cost/less polluting fuel such as natural gas, biogas and locally available agro-residues.
- Energy is an important input in the production.
- There are two ways to reduce energy dependency; energy conservation and substitution.
- Fuel substitution has taken place in all the major sectors of the Indian economy. Kerosene and Liquefied Petroleum Gas (LPG) have substituted soft coke in residential use.
- **Few examples of fuel substitution**
  - a) Natural gas is increasingly the fuel of choice as fuel and feedstock in the fertilizer, petrochemicals, power and sponge iron industries.

## ENERGY CONSERVATION AND MANAGEMENT

- b) Replacement of coal by coconut shells, rice husk etc.
- c) Replacement of LDO by LSHS
- **Few examples of energy substitution**
- a) Replacement of electric heaters by steam heaters
- b) Replacement of steam based hot water by solar

### Energy Balances

- Energy takes many forms, such as heat, kinetic energy, chemical energy, potential energy but because of interconversions it is not always easy to isolate separate constituents of energy balances.
- In many heat balances in which other forms of energy are insignificant; in some chemical situations mechanical energy is insignificant.
- Energy balances can be calculated on the basis of external energy used per kilogram of product, or raw material processed, or on dry solids or some key component.
- The energy consumed in food production includes direct energy which is fuel and electricity used on the farm, and in transport and in factories, and in storage, selling, etc.; and indirect energy which is used to actually build the machines, to make the packaging, to produce the electricity and the oil and so on.
- Food itself is a major energy source, and energy balances can be determined for animal or human feeding; food energy input can be balanced against outputs in heat and mechanical energy and chemical synthesis.
- The most common important energy form is heating energy and the conservation of this can be illustrated by considering operations such as heating and drying.

### Summary

1. Energy balances can be worked out quantitatively knowing the amounts of materials entering into a process, and the nature of the process.
2. Energy balances take the basic form  $\text{Content of inputs} = \text{content of products} + \text{wastes/losses} + \text{changes in stored materials}$ .
3. In continuous processes, a time balance must be established.
4. Energy includes heat energy (enthalpy), potential energy (energy of pressure or position), kinetic energy, work energy, chemical energy. It is the sum over all of these that is conserved



**Energy Audit -Methodology**

A comprehensive ten-step methodology for conduct of Energy Audit at field level is presented below. Energy Manager and Energy Auditor may follow these steps to start with and add/change as per their needs and industry types

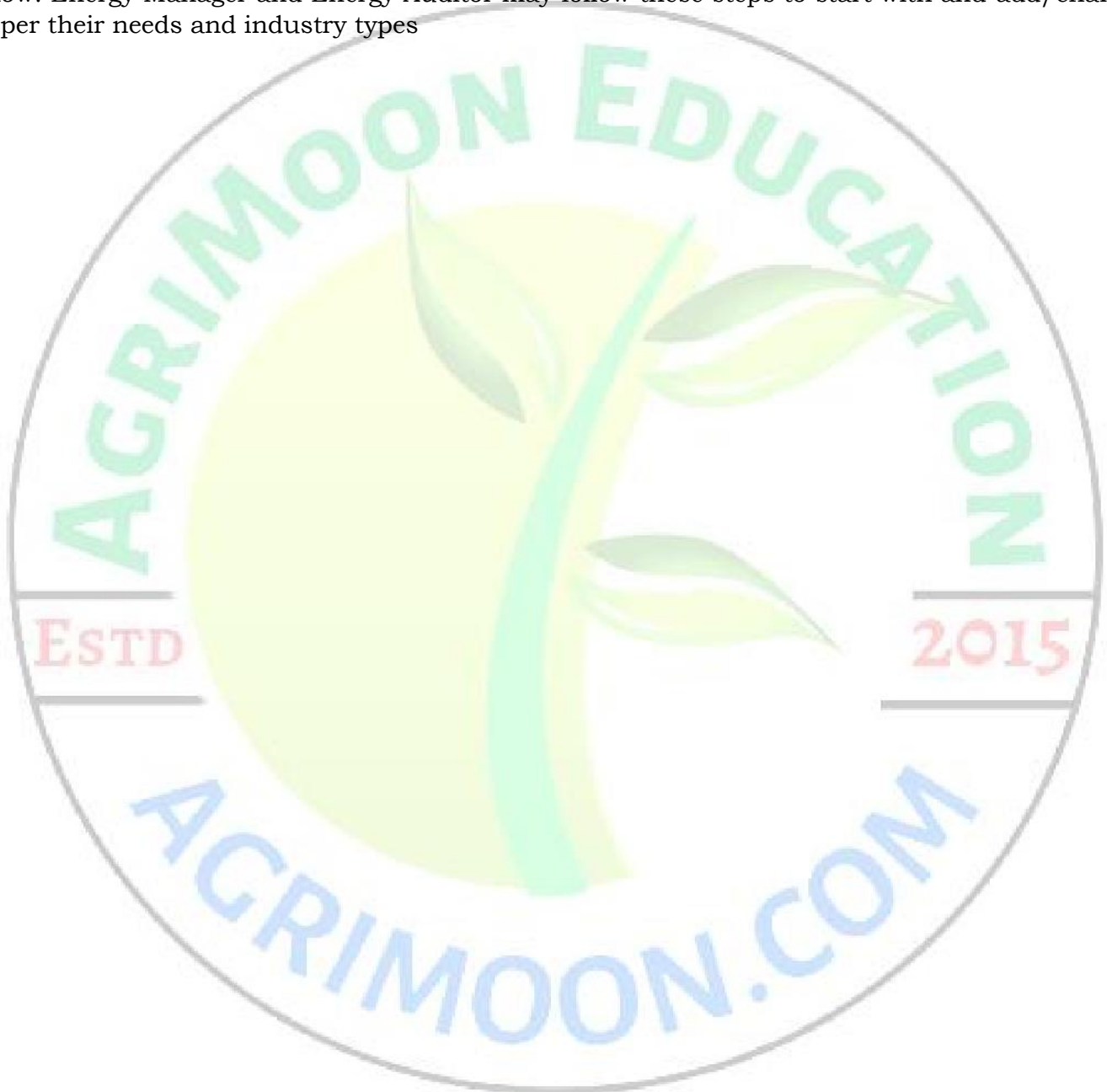

## Ten Steps Methodology for Detailed Energy Audit

Step No	PLAN OF ACTION	PURPOSE / RESULTS
	<u>Phase I—Pre Audit Phase</u>	
Step 1	<ul style="list-style-type: none"> <li>Plan and organise</li> <li>Walk through Audit</li> <li>Informal Interview with Energy Manager, Production / Plant Manager</li> </ul>	<ul style="list-style-type: none"> <li>Resource planning, Establish/organize a Energy audit team</li> <li>Organize Instruments &amp; time frame</li> <li>Macro Data collection (suitable to type of industry.)</li> <li>Familiarization of process/plant activities</li> <li>First hand observation &amp; Assessment of current level operation and practices</li> </ul>
Step 2	<ul style="list-style-type: none"> <li>Conduct of brief meeting / awareness programme with all divisional heads and persons concerned (2-3 hrs.)</li> </ul>	<ul style="list-style-type: none"> <li>Building up cooperation</li> <li>Issue questionnaire for each department</li> <li>Orientation, awareness creation</li> </ul>
	<u>Phase II—Audit Phase</u>	
Step 3	<ul style="list-style-type: none"> <li>Primary data gathering, Process Flow Diagram, &amp; Energy Utility Diagram</li> </ul>	<ul style="list-style-type: none"> <li>Historic data analysis, Baseline data collection</li> <li>Prepare process flow charts</li> <li>All service utilities system diagram (Example: Single line power distribution diagram, water, compressed air &amp; steam distribution.</li> <li>Design, operating data and schedule of operation</li> <li>Annual Energy Bill and energy consumption pattern (Refer manual, log sheet, name plate, interview)</li> </ul>
Step 4	<ul style="list-style-type: none"> <li>Conduct survey and monitoring</li> </ul>	<ul style="list-style-type: none"> <li>Measurements : Motor survey, Insulation, and Lighting survey with portable instruments for collection of more and accurate data. Confirm and compare operating data with design data.</li> </ul>
Step 5	<ul style="list-style-type: none"> <li>Conduct of detailed trials /experiments for selected energy guzzlers</li> </ul>	<ul style="list-style-type: none"> <li>Trials/Experiments: <ul style="list-style-type: none"> <li>24 hours power monitoring (MD, PF, kWh etc.).</li> <li>Load variations trends in pumps, fan compressors etc.</li> </ul> </li> </ul>

## ENERGY CONSERVATION AND MANAGEMENT

Step6	<ul style="list-style-type: none"> <li>• Analysis of energy use</li> </ul>	<ul style="list-style-type: none"> <li>- Boiler/Efficiency trials for (4 – 8 hours)</li> <li>- Furnace Efficiency trials Equipments Performance experiments etc</li> <li>• Energy and Material balance &amp; energy loss/waste analysis</li> </ul>
Step 7	<ul style="list-style-type: none"> <li>• Identification and development of Energy Conservation (ENCON) opportunities</li> </ul>	<ul style="list-style-type: none"> <li>• Identification &amp; Consolidation ENCON measures</li> <li>• Conceive, develop, and refine ideas</li> <li>• Review the previous ideas suggested by unit personal</li> <li>• Review the previous ideas suggested by energy audit if any</li> <li>• Use brainstorming and value analysis techniques</li> <li>• Contact vendors for new/efficient technology</li> </ul>
Step 8	<ul style="list-style-type: none"> <li>• Cost benefit analysis</li> </ul>	<ul style="list-style-type: none"> <li>• Assess technical feasibility, economic viability and prioritization of ENCON options for implementation</li> <li>• Select the most promising projects</li> <li>• Prioritise by low, medium, long term measures</li> </ul>
Step9	<ul style="list-style-type: none"> <li>• Reporting &amp; Presentation to the Top Management</li> </ul>	<ul style="list-style-type: none"> <li>• Documentation, Report Presentation to the top Management.</li> </ul>
Step10	<p><u>Phase III –Post Audit phase</u></p> <ul style="list-style-type: none"> <li>• Implementation and Follow-up</li> </ul>	<p>Assist and Implement ENCON recommendation measures and Monitor the performance</p> <ul style="list-style-type: none"> <li>• Action plan, Schedule for implementation</li> <li>• Follow-up and periodic review</li> </ul>

### 1.10 Barriers to Energy Conservation

Traditional energy prices are understated because they do not include the health, social, and environmental costs of using fuels. For example, gasoline prices do not consider the costs associated with military requirements to protect access to oil sources, global warming, acid rain, and adverse health effects. This is an institutional barrier to increasing energy efficiency. Some of the key barriers to achieving increased efficiency are listed below.



## ENERGY CONSERVATION AND MANAGEMENT

### **Lack of Objective Consumer Information**

Efficiency claims in the market place are often made by competing manufacturers, without an objective third party to evaluate the actual efficiency claims.

### **Failure of Consumers to Make Optimal Energy-Efficiency Decisions**

Consumers often choose the least expensive appliance, rather than the appliance that will save them money over the long term; consumers are also often confused about efficiency ratings and efficiency improvements.

### **Replacement Market Decisions Based on Availability Rather Than Efficiency**

Decisions concerning replacement of worn out or broken equipment are made without energy efficiency as a high priority. Usually, the primary concern for the consumer is restoring service as quickly as possible. This requires buying whatever equipment the plumbing or heating contractor may have on hand.

### **Energy Prices do not consider the Full Environmental or Societal Costs**

External costs associated with public health, energy production, global warming, acid rain, air pollution, energy security, or reliability of supply are usually ignored.

### **Competition for Capital to Make Energy-Efficiency Investments**

Energy-efficiency investments in the commercial and industrial sectors often must compete with other business investments; therefore, efficiency investments with a payback of more than 3 years are avoided.

### **The Separation of Building Ownership from Utility Bill Responsibility**

Renters will rarely make energy-efficiency investments in buildings that they do not own, especially when the utilities are included in the rent.

### **Commercial Buildings and Retail Space are Usually Built on Speculation with Low First-Cost a Priority**

The building's long-term operation cost, which is usually paid by the tenant(s) rather than the owner, is not important to the speculator/builder.

### **Instruments and Metering for Energy Audit**

The requirement for an energy audit is to identify and quantify where energy is being used necessitates measurements. These measurements require the use of instruments. The basic instruments used in energy audit work are listed below. These instruments are portable, durable, easy to operate and relatively inexpensive.

### **Key Performance Parameters for Energy Audit**

Basic Electrical Parameters in AC & DC systems Voltage (V), Current (I), Power factor, Active power (kW), Maximum demand (kVA), Reactive power (kVAr), Energy consumption (kWh), Frequency (Hz), Harmonics, etc.

Parameters of importance other than electrical such as Temperature and Heat Flow, Radiation, Air and Gas Flow, Liquid Flow, RPM, Air Velocity, Noise and Vibration, Dust Concentration, TDS, PH, Moisture Content, Relative Humidity, Flue Gas Analysis CO<sub>2</sub>, O<sub>2</sub>, CO, SO<sub>x</sub>, NO<sub>x</sub>, Combustion Efficiency etc.

Some of the instruments commonly used in an energy audit are described as follows.

### **Energy Audit Instruments**

#### **Electrical Measuring Instruments:**

## ENERGY CONSERVATION AND MANAGEMENT



These are instruments for measuring major electrical parameters such as kVA, kW, PF, Hertz, kVA, Amps and Volts. In addition, some of these instruments also measure harmonics.



These instruments are applied on-line i.e on running motors without any need to stop the motor. Instant measurements can be taken with hand-held meters, while more advanced ones facilitate cumulative readings with print outs at specified intervals.

### Combustion analyser:

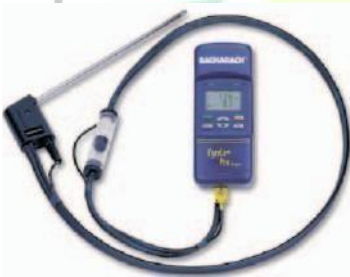

This instrument has in-built chemical cells which measure various gases such as O<sub>2</sub>, CO, NO<sub>x</sub> and SO<sub>x</sub>.

### Fuel Efficiency Monitor:



This measures oxygen and temperature of the flue gas. Calorific values of common fuels are fed into the microprocessor which calculate the combustion efficiency.

### Fyrite

## ENERGY CONSERVATION AND MANAGEMENT



A hand bellow pump draws the flue gas sample into the solution inside the fyrite. A chemical reaction changes the liquid volume revealing the amount of gas. A separate fyrite can be used for O<sub>2</sub> and CO<sub>2</sub> measurement.

### **Contact thermometer:**

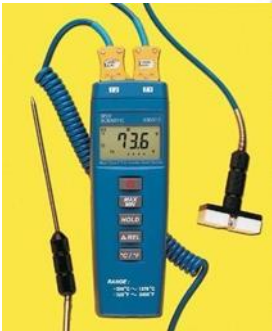

These are thermocouples which measures for example flue gas, hot air, hot water temperatures by insertion of probe into the stream.

For surface temperature, a leaf type probe is used with the same instrument.

### **Non-contact Infrared Thermometer:**



This is a non-contact type measurement which when directed at a heat source directly gives the temperature read out. This instrument is useful for measuring hot spots in furnaces, surface temperatures etc.

### **Pitot Tube and manometer:**





## ENERGY CONSERVATION AND MANAGEMENT

Air velocity in ducts can be measured using a pitot tube and inclined manometer for further calculation of flows.

### Ultrasonic Water flow meter:



This non-contact flow measuring device using Doppler effect / Ultra sonic principle. There is a transmitter and receiver which are positioned on opposite sides of the pipe. The meter directly gives the flow. Water and other fluid flows can be easily measured with this meter.

### Speed Measurements:



Stroboscope

#### Tachometer

In any audit exercise speed measurements are critical as they may change with frequency, belt slip and loading.

A simple tachometer is a contact type instrument which can be used where direct access is possible.

More sophisticated and safer ones are non-contact instruments such as stroboscopes.

### Leak Detectors:



## ENERGY CONSERVATION AND MANAGEMENT

Ultrasonic instruments are available which can be used to detect leaks of compressed air and other gases which are normally not possible to detect with human abilities.

### Lux meters:



### Lux Meters:

A light sensitive cell measures the incident light (all light in the visible spectrum is measured) and evaluates that against the human daylight sensitivity curve. The resulting value is the measurement result in lux. This works well but it requires a different correction factor for every light spectrum.

The much more expensive lux meters with one cell are optimized and tuned with optical filters and lenses such that the sensitivity of this set of lenses and the cell itself directly matches the eye's light sensitivity curve (so only one correction value needed for light of any spectral content).

### Smart Energy Meters



The term smart meter usually refers to electric meters which keep detailed statistics on usage, but it can be used for fuels or water applications as well performing the same job. The primary purpose of smart meters is to provide information on how end users use their electricity on a real-time basis. The smart energy meters use a wireless communication to help track the electricity consumption and thus save both electricity and money. It can be easily installed and gives an accurate reading of electricity consumption which can also be monitored/controlled through mobile or internet.

### Psychrometer:

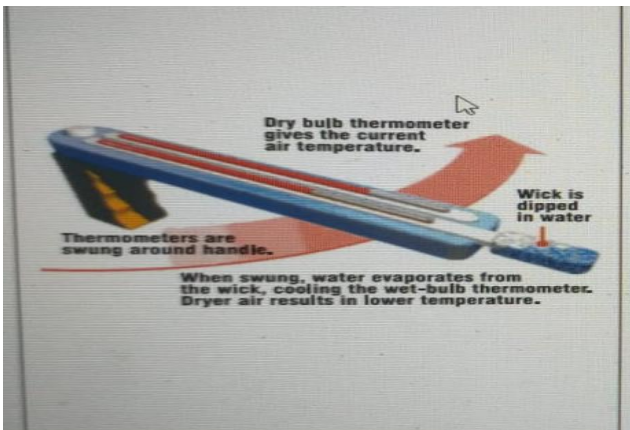

A sling psychrometer - consists of two thermometers mounted together with a handle. One thermometer is ordinary and measures the dry bulb temperature. The other has a wet cloth wick, over its bulb and is called a wet-bulb thermometer. When a reading is to be taken the psychrometer is whirled around. The water evaporates from the wick, cooling the wet-bulb thermometer. Then the temperatures of both thermometers are read. If the surrounding air is dry, more moisture evaporates from the wick, cooling the wet-bulb thermometer more, so there is a greater difference between the temperatures of the two thermometers. By using these temperatures, the humidity is computed.

### Thermography



Infra-red thermal monitoring and imaging (non-contact type) measures thermal energy radiation from hot/cold surfaces of an object and provides input for assessing health of equipment and predictive maintenance.

The thermal camera unit converts electromagnetic thermal energy (IR) radiated from an object into electronic video signals. These signals are amplified and transmitted via interconnected cable to a display monitor where the resulting image is analysed and interpreted for hot/cold spots.



**Lesson 4**

**HVAC AND REFRIGERATION SYSTEM**

**Introduction**

The Heating, Ventilation and Air Conditioning (HVAC) and refrigeration system transfers the heat energy from or to the products, or building environment. Energy in form of electricity or heat is used to power mechanical equipment designed to transfer heat from a colder, low-energy level to a warmer, high-energy level.

**REFRIGERATION**

Refrigeration deals with the transfer of heat from a low temperature level at the heat source to a high temperature level at the heat sink by using a low boiling refrigerant.

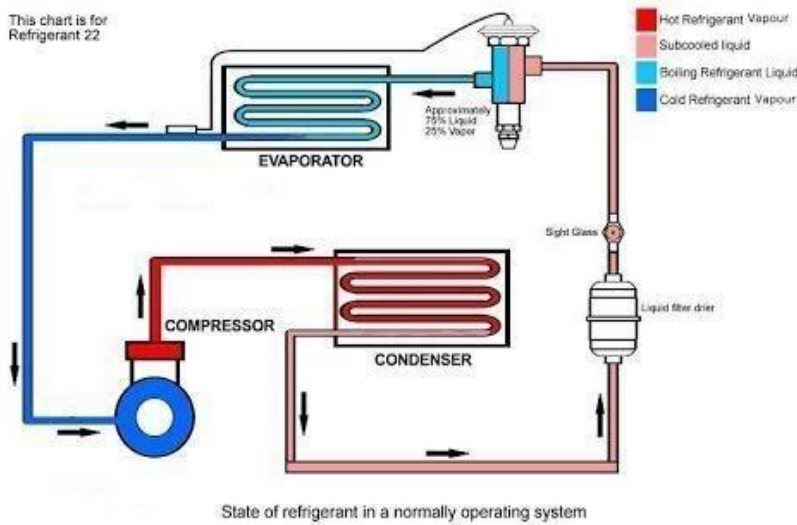

State of refrigerant in a normally operating system

There are several heat transfer loops in refrigeration system as described below:

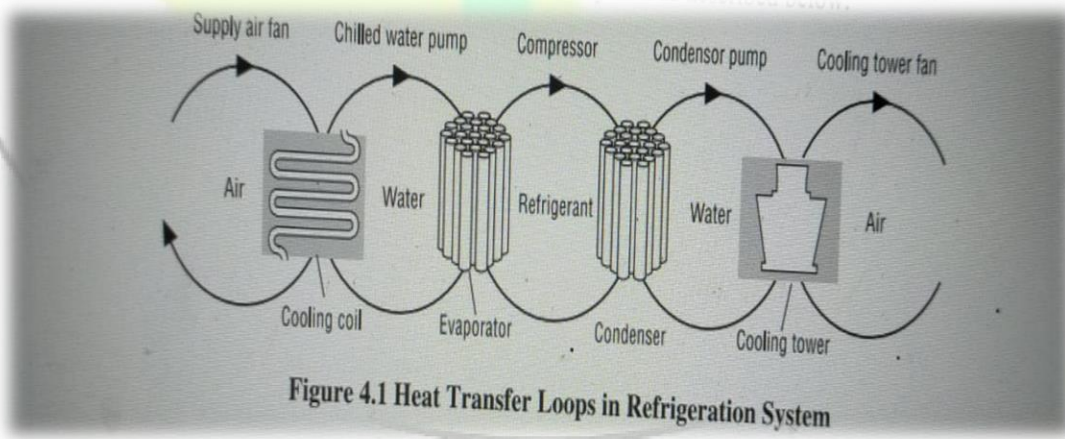

Figure 4.1 Heat Transfer Loops in Refrigeration System

In the Figure, thermal energy moves from left to right as it is extracted from the space and expelled into the outdoors through five loops of heat transfer:

**Indoor air loop.** In the leftmost loop, indoor air is driven by the supply air fan through a cooling coil, where it transfers its heat to chilled water. The cool air then cools the building space.

**Chilled water loop.** Driven by the chilled water pump, water returns from the cooling coil to the chiller's evaporator to be re-cooled.

## ENERGY CONSERVATION AND MANAGEMENT

**Refrigerant loop.** Using a phase-change refrigerant, the chiller's compressor pumps heat from the chilled water to the condenser water.

**Condenser water loop.** Water absorbs heat from the chiller's condenser, and the condenser water pump sends it to the cooling tower.

**Cooling tower loop.** The cooling tower's fan drives air across an open flow of the hot condenser water, transferring the heat to the outdoors.

### Factors Affecting Performance & Energy Efficiency of Refrigeration Plants

- Design of Process Heat Exchangers
- Maintenance of Heat Exchanger Surfaces
- Multi-Staging for Efficiency
- Capacity Control and Energy Efficiency
- Multi-level Refrigeration for Plant Needs
- Chilled Water Storage
- System Design Features

### Rules of Thumb for Refrigeration

- Refrigeration capacity reduces by 6% for every 3.5 °C increase in condensing temperature.
- Reducing condensing temperature by 5.5 °C results in a 20–25 % decrease in compressor power consumption.
- A reduction of 0.55 °C in cooling water temperature at condenser inlet reduces compressor power consumption by 3 percent.
- 1 mm scale build-up on condenser tubes can increase energy consumption by 40 percent.
- 5.5 °C increase in evaporator temperature reduces compressor power consumption by 20–25%

### Air-Conditioning Systems

Depending on applications, there are several options / combinations, which are available for use as given below:

- Air Conditioning (for comfort/machine)
- Split air conditioners
- Fan coil units in a larger system
- Air handling units in a larger system

### Refrigeration Systems (for processes)

- Refrigeration process is used in chilled water, brine for processes, ice plants, air conditioning, humidification – moisture removal etc
- Small capacity modular units of direct expansion type similar to domestic refrigerators, small capacity refrigeration units.
- Centralized chilled water plants with chilled water as a secondary coolant for temperature **range over 5 °C typically**. They can also be used for ice bank formation.
- **Brine plants, which use brines as lower temperature**, secondary coolant, for typically sub-zero temperature applications, which come as modular unit capacities as well as large centralized plant capacities.
- **The plant capacities up to 50 TR are usually considered as small capacity, 50-250 TR as medium capacity and over 250 TR as large capacity units.**

A large industry may have a bank of such units, often with common chilled water pumps, condenser water pumps, cooling towers, as an offsite utility.

The same industry may also have two or three levels of refrigeration & air conditioning such as:



## ENERGY CONSERVATION AND MANAGEMENT

- Comfort air conditioning (20-25 °C)
- Chilled water system (8-10°C)
- Brine system (sub-zero applications)

Two principle types of refrigeration plants found in industrial use are: Vapour Compression Refrigeration (VCR) and Vapour Absorption Refrigeration (VAR). VCR uses mechanical energy as the driving force for refrigeration, while VAR uses thermal energy as the driving force for refrigeration.

### Types of Refrigeration System

#### 1. Vapour Compression Refrigeration

Heat flows naturally from a hot to a colder body. In refrigeration system the opposite must occur i.e. heat flows from a cold to a hotter body. This is achieved by using a substance called a refrigerant, which absorbs heat and hence boils or evaporates at a low pressure to form a gas. This gas is then compressed to a higher pressure, such that it transfers the heat it has gained to ambient air or water and turns back (condenses) into a liquid. In this way heat is absorbed, or removed, from a low temperature source and transferred to a higher temperature source.

The refrigeration cycle can be broken down into the following stages (see Figure):

**1-2** Low pressure liquid refrigerant in the evaporator absorbs heat from its surroundings, usually air, water or some other process liquid. During this process it changes its state from a liquid to a gas, and at the evaporator exit is slightly superheated.

**2-3** The superheated vapour enters the compressor where its pressure is raised. There will also be a big increase in temperature, because a proportion of the energy input into the compression process is transferred to the refrigerant.

**3-4** The high pressure superheated gas passes from the compressor into the condenser. The initial part of the cooling process (3-3a) de super heats the gas before it is then turned back into liquid (3a 3b). The cooling for this process is usually achieved by using air or water. A further reduction in temperature happens in the pipe work and liquid receiver (3b-4), so that the refrigerant liquid is sub-cooled as it enters the expansion device.

**4-1** The high-pressure sub-cooled liquid passes through the expansion device, which both reduces its pressure and controls the flow into the evaporator.

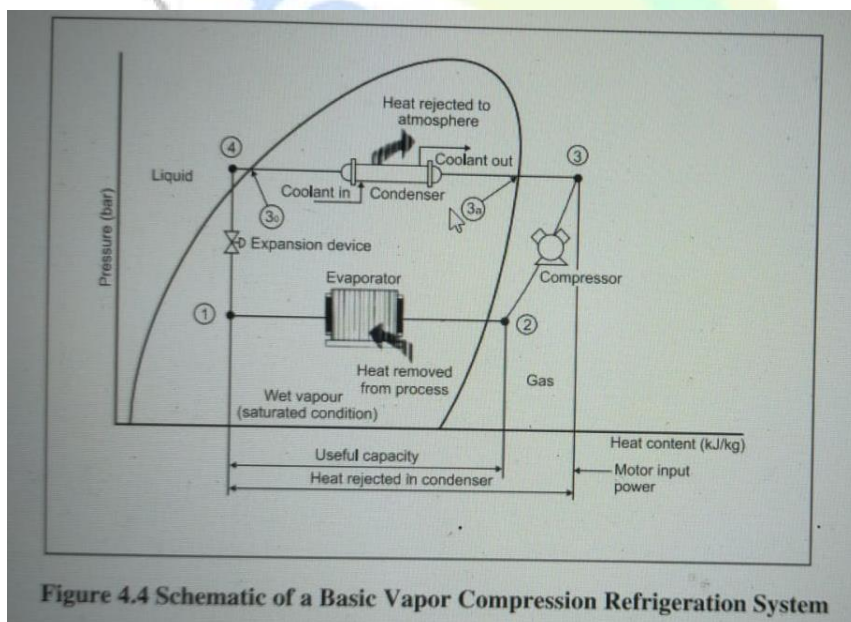



## ENERGY CONSERVATION AND MANAGEMENT

### 2. Absorption Refrigeration

The absorption chiller is a machine, which produces chilled water by using heat such as steam, hot water, gas, oil etc. Chilled water is produced by the principle that liquid (refrigerant), which evaporates at low temperature, absorbs heat from surrounding when it evaporates. Pure water is used as refrigerant and lithium bromide solution is used as absorbent

Heat for the vapour absorption refrigeration system can be provided by waste heat extracted from process, diesel generator sets etc. Absorption systems require electricity to run pumps only. Depending on the temperature required and the power cost, it may even be economical to generate heat / steam to operate the absorption system.

### 3. Evaporative Cooling

There are occasions where air conditioning, which stipulates control of humidity up to 50% for human comfort or for process, can be replaced by a much cheaper and less energy intensive evaporative cooling.

The concept is very simple and is the same as that used in a cooling tower. Air is brought in close contact with water to cool it to a temperature close to the wet bulb temperature. The cool air can be used for comfort or process cooling. The disadvantage is that the air is rich in moisture. Nevertheless, it is an extremely efficient means of cooling at very low cost. Large commercial systems employ cellulose filled pads over which water is sprayed. The temperature can be controlled by controlling the airflow and the water circulation rate. The possibility of evaporative cooling is especially attractive for comfort cooling in dry regions. This principle is practiced in textile industries for certain processes.

### Energy Conservation Opportunities in Refrigeration Systems

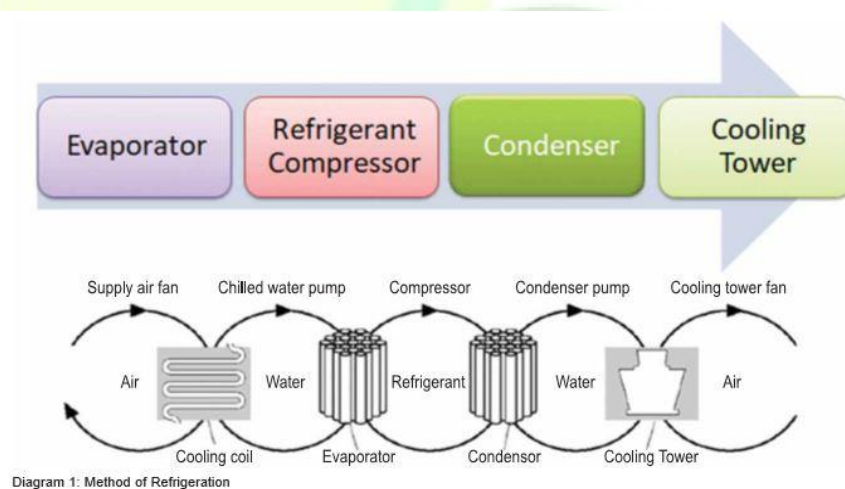

### Energy Conservation opportunities in Chillers

- Use water-cooled condensers rather than air-cooled condensers.
- Challenge the need for refrigeration, particularly, for old batch recesses.
- Avoid oversizing – match the connected load.
- Consider gas-powered refrigeration equipment to minimize electrical demand charges.
- Use free cooling to allow chiller shutdown in cold weather.
- Use refrigerated water loads in series if possible. Convert firewater or other tanks to thermal storage.
- Don't assume that the old way is still the best – particularly, for energy intensive low temperature systems.
- Correct inappropriate brine or glycol concentration that adversely affects heat transfer and/or pumping energy.

## ENERGY CONSERVATION AND MANAGEMENT

- If it sweats, insulate it, but if it is corroding, replace it first.
  - Adjust minimize hot gas bypass operation.
  - Inspect moisture/liquid indicators.
  - Consider change of refrigerant type if it will improve efficiency.
  - Check for correct refrigerant charge level.
  - Inspect the purge for air and water leaks.
  - Establish a refrigeration efficiency maintenance program. Start with an energy audit and follow-up, then make a refrigeration efficiency-maintenance program a part of your continuous energy management program.
- Increase the chilled water temperature set point if possible. Use the lowest temperature condenser water available that the chiller can handle. (Reducing condensing temperature by 5.5 0C, results in a 20 – 25 per cent decrease in compressor power consumption)
- Increase the evaporator temperature (5.50C increase in evaporator temperature reduces compressor power consumption by 20 – 25 per cent)
- Clean heat exchangers when fouled. (1 mm scale build-up on condenser tubes can increase energy consumption by 40 per cent)
- Optimise condenser water flow rate and refrigerated water flow rate.
- Replace old chillers or compressors with new higher-efficiency models.
- Use water-cooled rather than air-cooled chiller condensers.
- Use energy-efficient motors for continuous or near-continuous operation.
- Specify appropriate fouling factors for condensers.
- Do not overcharge oil.
- Install a control system to coordinate multiple chillers.
- Study part-load characteristics and cycling costs to determine the most efficient mode for operating multiple chillers.
- Run the chillers with the lowest energy consumption. It saves energy cost, fuels a base load.
- Avoid oversizing – match the connected load.
- Isolate off-line chillers and cooling towers.
- Establish a chiller efficiency maintenance program. Start with an energy audit and follow-up, then make a chiller efficiency-maintenance program a part of your continuous energy management program

## HVAC Systems

HVAC System consists of a chain of components designed to cool or heat, ventilate a specific area while maintaining a defined environmental cleanliness level. Purpose of HVAC system is to Control/ Maintain Temperature – Heating,

To Purify the Air – Ventilation and

To Control/Maintain Humidity – Air Conditioning.

- Optimum Design (Heat Load and Air Flow Requirements)
- Monitoring & Control
- Automation
- Effective Preventive Maintenance
- Minimisation of Heat Energy Losses
- Minimisation of Leakage Losses
- Energy Efficient HVAC Components
- Waste Heat Recovery
- Tune up the HVAC control system.
- Consider installing a building automation system (BAS) or energy management system (EMS) or restoring an out-of-service one.

## ENERGY CONSERVATION AND MANAGEMENT

- Balance the system to minimise flows and reduce blower or fan or pump power requirements.
- Eliminate or reduce reheat whenever possible. Use appropriate HVAC thermostat setback.
- Use morning pre-cooling in summer and pre-heating in winter (i.e. Before electrical peak hours).
- Use building thermal lag to minimise HVAC equipment operating time.
- In winter during unoccupied periods, allow temperatures to fall as low as possible without freezing water lines or damaging stored materials.
- In summer during unoccupied periods, allow temperatures to rise as high as possible without damaging stored materials.
- Improve control and utilisation of outside air.
- Use air-to-air heat exchangers to reduce energy requirements for heating and cooling of outside air.
- Reduce HVAC system operating hours (e.g. – night, weekend).
- Optimize ventilation.
- Ventilate only when necessary.
- To allow some areas to be shut down when unoccupied, install dedicated HVAC systems on continuous loads (e.g. – computer rooms).
- Provide dedicated outside air supply to kitchens, cleaning rooms, combustion equipment, etc to avoid excessive exhausting of conditioned air.
- Use evaporative cooling in dry climates.
- Reduce humidification or dehumidification during unoccupied periods.
- Establish an HVAC efficiency maintenance program. Start with an energy audit and follow-up, then make an HVAC efficiency-maintenance program a part of your continuous energy management program.
- Use atomisation rather than steam for humidification where possible.
- Clean HVAC unit coils periodically and combs mashed fins.
- Upgrade filter banks to reduce pressure drop and thus lower fan power requirements.
- Check HVAC filters on a schedule (at least monthly) and clean/change if appropriate.
- Check pneumatic controls air compressors for proper operation, cycling, and maintenance.
- Isolate air-conditioned loading dock areas and cool storage areas using high-speed doors or clear PVC strip curtains.
- Install ceiling fans to minimise thermal stratification in high-bay areas.
- Relocate air diffusers to optimum heights in areas with high ceilings.
- Consider reducing ceiling heights.
- Eliminate obstructions in front of radiators, baseboard heaters, etc.
- Check reflectors on infrared heaters for cleanliness and proper beam direction.
- Use professionally-designed industrial ventilation hoods for dust and vapor control.
- Use local infrared heat for personnel rather than heating the entire area.
- Use spot cooling and heating (e.g. — use ceiling fans for personnel rather than cooling the entire area).
- Purchase only high-efficiency models for HVAC window units.
- Put HVAC window units on timer control.
- Don't oversize cooling units. (Oversized units will short cycle which results in poor humidity control.)
- Install multi-fuelling capability and run with the cheapest fuel available at the time.
- Consider dedicated make-up air for exhaust hoods. (Why exhaust the air conditioning or heat if you don't need to?)
- Minimise HVAC fan speeds.
- Consider desiccant drying of outside air to reduce cooling requirements in humid climates.
- Consider ground source heat pumps.
- Seal leaky HVAC ductwork.
- Seal all leaks around coils.
- Repair loose or damaged flexible connections (including those under air handling units).



## ENERGY CONSERVATION AND MANAGEMENT

- Eliminate simultaneous heating and cooling during seasonal transition periods.
- Zone HVAC air and water systems to minimize energy use.
- Inspect, clean, lubricate, and adjust damper blades and linkages

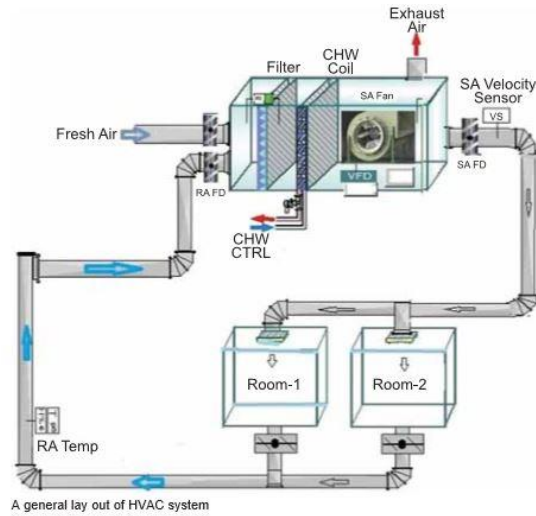

System	AHU with 100% Fresh Air requirements
Capacity	10000 CFM / 25 TR
Ambient Air Temperature	35°C
Room Temperature Requirement	25°C
Exhaust Air Requirement	27°C
Reduction in Fresh Air Temperature by heat transfer between exhaust air & fresh air	30 – 32 °C
% Reduction in Heat Load by Utilization of heat in Exhaust Air	8.5% - 10 %

## Energy Efficient System Design & Selection

The greatest opportunities for energy efficiency exist at the design stage for HVAC system. HVAC Design should not be tailor made as its operating cost and performance is totally depended on local environmental condition, optimum capacity by considering season variation as well as energy efficiency is the most important part of any pharmaceutical HVAC systems.

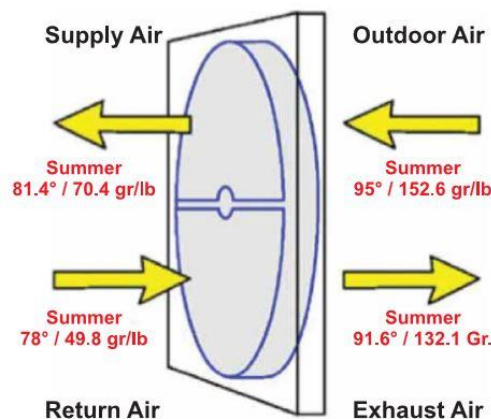

## Whole Building Approach in HVAC

1. Reduce cooling load by controlling unwanted heat gain
2. System interactions

## ENERGY CONSERVATION AND MANAGEMENT

3. Expand the comfort envelope with reduced radiant heat load, increased air flow, less insulated furniture, more casual dress where appropriate
4. Apply non-vapor compression cooling techniques
5. Serve the remaining load with high efficiency refrigerative cooling
6. Optimize the delivery system
7. Improve controls
8. Determining loads

## Energy Saving Opportunities

- Cold Insulation
- Building Envelope
- Building Heat Loads Minimisation
- Process Heat Loads Minimisation
- At the Refrigeration A/C Plant Area

## Energy Monitoring & Control System

An energy monitoring and control system supports the operation of HVAC system by monitoring, controlling and tracking system energy consumption. Such system continuously manages and optimises HVAC System energy Figures of Waste heat recovery and saving energy consumption and identifying potential technical problem in HVAC system.

Example: For monitoring and control of HVAC, BMS System should be preferred along with configuration of current or power measurement HVAC System also for maintaining room pressure motorised damper should be installed to maintain the required parameter with energy efficiency.

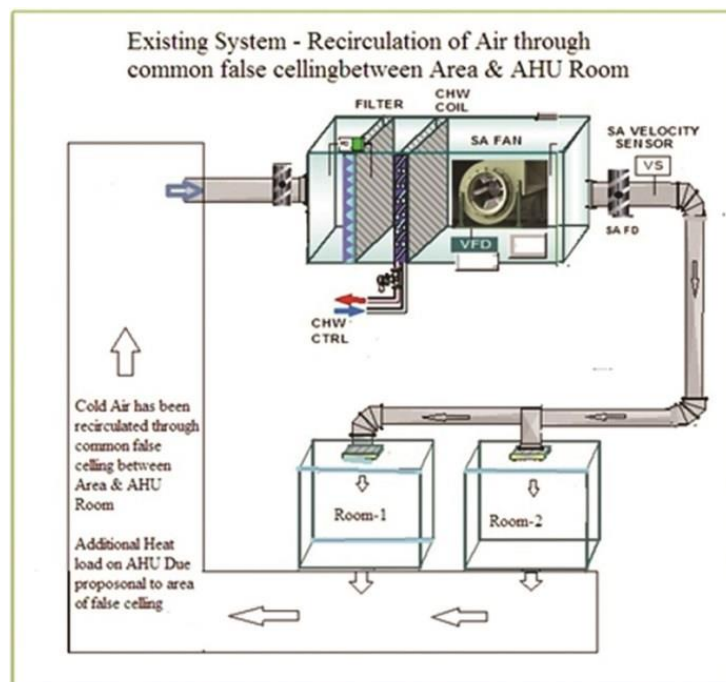

## ENERGY CONSERVATION AND MANAGEMENT

### Automation and Loss Minimisations

- Installation of VFDs for Air Blower Modulation accordingly air flow requirements will reduce energy consumption at part load operations.
- Installation of 2-way or 3-way valves will modulate chilled water flow as per indoor environmental condition which reduce load on chiller.
- Heat energy losses from leakages through door and windows lead to lowering energy efficiency in HVAC systems.

### Waste Heat Recovery

Utilisation of heat energy available in exhaust air by reducing fresh air temperature through heat transfer between fresh air and exhaust air.

- If existing return air is through common false ceiling area between AHU room and conditioned area, additional load (of above false ceiling area) approximately 15 to 18 per cent has been added in actual requirement of HVAC System.
  - Appropriate size of return air duct required which is to be connected with AHU inlet with provision of fresh air duct with damper on both return air as well as fresh air duct.
  - Fresh air damper and return air damper open or close position to be set accordingly temperature of return air temperature and fresh air temperature.
  - Lower temperature air intake rate to be increased by setting damper accordingly
  - Provision of return duct in place of return through false ceiling for recirculation Type HVAC System.

### Evaporative Cooling System

#### Objective

- Utilisation of ETP/ STP treated water to maintain zero discharge condition and simultaneously utilisation of treated water for fresh air-cooling media.

#### Principal of Operation

After being cooled by Cooling Tower Treated Water has been recirculated in fresh air-cooling unit to reduce the Inlet Air Temperature (Ambient). Air Cooled by Fresh Air-Cooling System has been supplied to main HVAC Systems instead of taking fresh air directly at ambient temperature HVAC System have inlet air with reduced temperature than ambient air which in turns reduction of reduction of heat load on chilled water-cooling coil, ultimately, saving in power consumption of chilling plant.



$$\text{Pump efficiency} = \frac{\text{Hydraulic power, } P_h}{\text{Power input to the pump shaft}} \times 100$$

Where,

$$\text{Hydraulic power } P_h(\text{kW}) = Q \times (h_d - h_s) \times \rho \times g / 1000$$

Q = Volume flow rate (m<sup>3</sup> / s), ρ = density of the fluid (kg/m<sup>3</sup>), g = acceleration due to gravity (m/s<sup>2</sup>), (h<sub>d</sub> - h<sub>s</sub>) = Total head in metres

- Ensure adequate NPSH at site of installation
- Ensure availability of basic instruments at pumps like pressure gauges, flow meters.
- Operate pumps near best efficiency point.
- Modify pumping system and pumps losses to minimize throttling.
- Adapt to wide load variation with variable speed drives or sequenced control of multiple units.
- Stop running multiple pumps - add an auto-start for an on-line spare or add a booster pump in the problem area.
- Use booster pumps for small loads requiring higher pressures.
- Increase fluid temperature differentials to reduce pumping rates in case of heat exchangers.
- Repair seals and packing to minimize water loss by dripping.
- Balance the system to minimize flows and reduce pump power requirements.
- Avoid pumping head with a free-fall return (gravity); Use siphon effect to advantage:
- Conduct water balance to minimize water consumption
- Avoid cooling water re-circulation in DG sets, air compressors, refrigeration systems, cooling towers feed water pumps, condenser pumps and process pumps.
- In multiple pump operations, carefully combine the operation of pumps to avoid throttling
- Provide booster pump for few areas of higher head
- Replace old pumps by energy efficient pumps
- In the case of over designed pump, provide variable speed drive, or downsize / replace impeller or replace with correct sized pump for efficient operation.
- Optimize number of stages in multi-stage pump in case of head margins
- Reduce system resistance by pressure drop assessment and pipe size optimization.

### **pumps and pumping systems**

- Pump is a device used to move fluid such as liquids, gases or slurries.
- It increases the mechanical energy of the fluid. The additional energy can be used to increase, Velocity (flow rate), Pressure, Elevation

#### **Pump Tips to Save Energy on Pumping Systems.**

##### **1.Select the most efficient pump type for the application**

##### **2.Right-size the pump**

- Right-sizing the pump represents a significant economic opportunity to reduce energy consumption.
- Oversizing of the pump causes higher energy and maintenance costs.

##### **3.Trim the impeller**

## ENERGY CONSERVATION AND MANAGEMENT

- The impeller should not be trimmed any smaller than the minimum diameter shown on the manufacturer's pump curve.
- In practice, impeller trimming is typically used to avoid throttling losses associated with control valves.

### **4.Minimize system pressure drop**

- A key way to reduce pressure drop is through pipe-sizing optimization.
- Hydraulic friction loss creates a reduction in pressure from one end of a straight pipe to another.
- Factors such as the flow rate, pipe size, overall pipe length, pipe characteristics and properties of the fluid being pumped all influence the system pressure drop.

### **5.Implement proper control valves**

- Control valves are typically used to control flow and/or pressure.
- They can help to reduce energy losses over non-controlled systems such as irrigation systems with a fixed-speed pump and multiple locations with different distances and elevations.
- The main functions of control valves are throttling flow or for bypassing flow.
- Throttling reduces the flow but increases the pressure. You can minimize excess pressure by bypassing excess flow back to the reservoir or another location.

### **6.Implement variable speed drives (VSDs)**

### **7.Maintain pumping systems effectively**

- Regular maintenance may reveal deteriorations in efficiency and capacity, which can occur long before a pump fails.
- Most maintenance activities can be classified as either preventive or predictive.
- Preventive maintenance addresses routine system needs such as lubrication, periodic adjustments, and removal of contaminants.
- Predictive maintenance focuses on tests and inspections that detect deteriorating conditions.

### **8.Use higher efficiency/proper pump seals**

- Leaks from static and dynamic seals waste fluid and can contaminate the environment.
- Leaks between the pump suction to the pump discharge reduce pump volumetric efficiency.
- Dynamic seals consume energy from the mechanical friction between the static and moving parts.
- Potential sealing system savings can exceed the energy savings obtained from switching to variable frequency drives, trimming impellers, or re-sizing pumps in many applications.

### **9.Use multiple pumps**

## ENERGY CONSERVATION AND MANAGEMENT

- When multiple pumps operate as part of a parallel pumping system, there are opportunities for significant energy savings.
- A multiple pump parallel system works best when each pump is run individually, not concurrently, most or all of the time.

### 10. Eliminate unnecessary uses

- One of the simplest measures to save energy is to eliminate unnecessary use.
- Pumping system efficiency measures include shutting down unnecessary pumps and using pressure switches to control the number of pumps in service when flow-rate requirements vary.
- Each pump system is different and there are many opportunities to save energy.

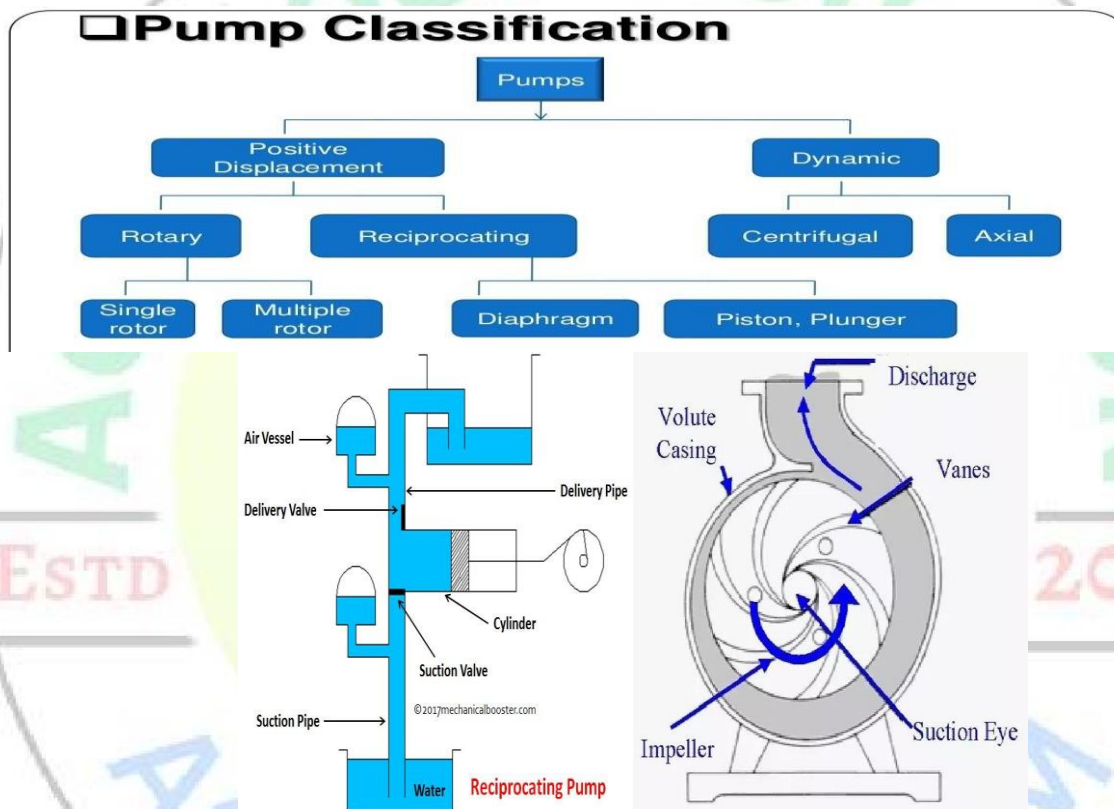

### Energy Efficiency / Saving Measures in Fans & Blowers

1. Minimizing excess air level in combustion systems to reduce FD fan and ID fan load.
2. Minimizing air in-leaks in hot flue gas path to reduce ID fan load, especially in case of kilns, boiler plants, furnaces, etc. Cold air in-leaks increase ID fan load tremendously, due to density increase of flue gases and in-fact choke up the capacity of fan, resulting as a bottleneck for boiler / furnace itself.
3. In-leaks / out-leaks in air conditioning systems also have a major impact on energy Efficiency and fan power consumption and need to be minimized.

**The findings of performance assessment trials will automatically indicate potential areas for improvement, which could be one or a more of the following:**

1. Change of impeller by a high efficiency impeller along with cone.
2. Change of fan assembly as a whole, by a higher efficiency fan
3. Impeller de-rating (by a smaller dia impeller)



## ENERGY CONSERVATION AND MANAGEMENT

4. Change of metallic / Glass reinforced Plastic (GRP) impeller by the more energy Efficient hollow FRP impeller with aerofoil design, in case of axial flow fans, where significant savings have been reported

5. Fan speed reduction by pulley dia modifications for derating

6. Option of two speed motors or variable speed drives for variable duty conditions

7. Option of energy efficient flat belts, or, cogged raw edged V belts, in place of conventional V belt systems, for reducing transmission losses.

8. Adopting inlet guide vanes in place of discharge damper control

9. Minimizing system resistance and pressure drops by improvements in duct system

Equipment	Specific ratio	Pressure rise (mm Wg)
Fans	Up to 1.11	1136
Blowers	1.11- 1.20	1136-2066

## TYPES OF FANS AND BLOWERS

Depending on the direction of the air flow Fans are classified into,

### 1) Centrifugal flow fan

- Air flow changes its direction twice
- Radial fans, Forward curved fans, Backward inclined fans

### 2) Axial flow fan

- Air enter and exit without change in direction of flow
- Tube axial fans, Vane axial fans, Propeller fans

Major blower types are,

### 1) Centrifugal blower

Similar to centrifugal fan but can achieve high pressure

### 2) Positive displacement blower

Provides constant volume of air

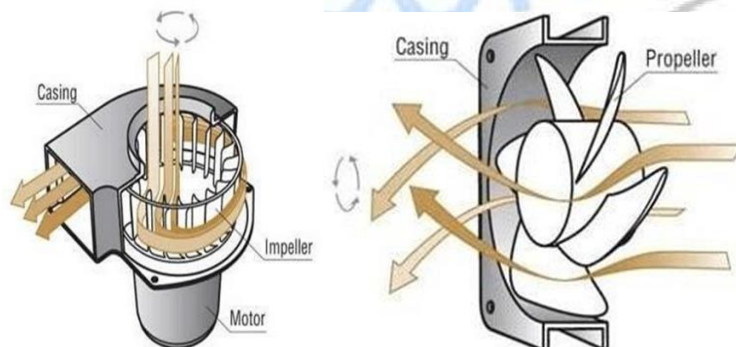

**A. Centrifugal Fans:-**

- Rotating impeller increases air velocity.
- Air speed is converted to pressure.
- This fans produces High Pressure which ranges from 550 mmwc to 1400 mmwc.
- Efficiency varies from 60-83 %.
- Used for Dirty air stream condition and material handling application

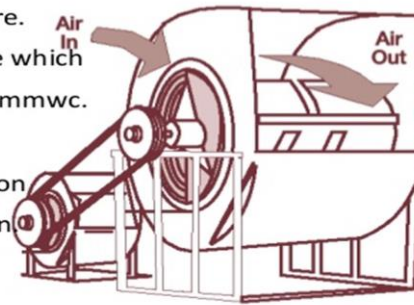

Fig. Centrifugal Fans

It categorized by blade shapes,

- 1.Radial
- 2.Forward curved
- 3.Backward curved

**B. Axial Fans**

- Air is pressurized by blades which creating aerodynamic lift.
- Typically provide large air volumes at relatively low pressures pressure ranges from 250mmwc to 500mmwc.
- Efficiency varies from 45% - 85%.
- Popular with industry as compact, low cost and light weight.
- Axial fans are frequently used in exhaust applications where airborne particulate size is small, such as dust streams, smoke, and steam.

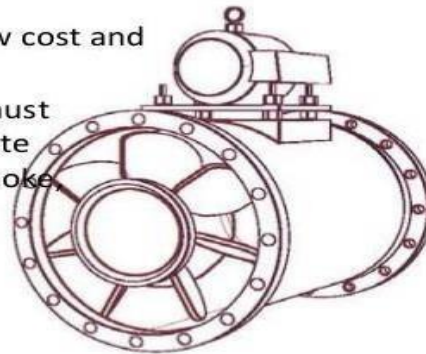
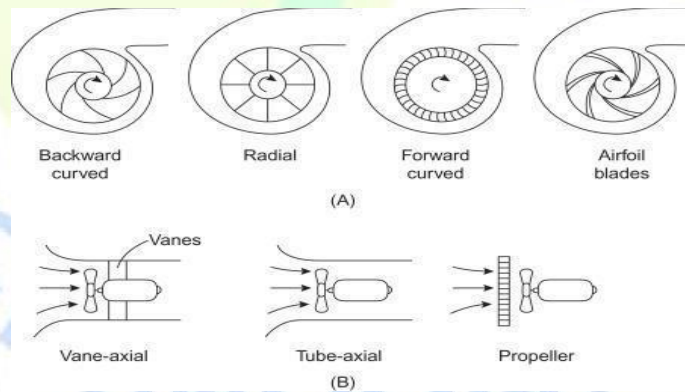

Fig. Axial Fan

- It categorized as,
- 1.Propellor Axial Fan
  - 2.Tube Axial Fan
  - 3.Vane Axial Fan



**BLOWER**

- Blower can achieve much higher pressure than fans, as high as 1.20 kg/cm<sup>2</sup>
- The impeller is typically gear driven and rotates as fast as 15000 rpm
- They are also used to produce negative pressures for industrial vacuum systems

**1.Centrifugal blowers**

- Typically operates against pressures of 0.35 to 0.70 Kg/cm<sup>2</sup>
- They are most often used in applications that are not prone to clogging

**2.Positive displacement blower**

## ENERGY CONSERVATION AND MANAGEMENT

- They are especially suitable for applications prone to clogging,
- Since they can produce enough pressure up to 1.25 g/cm<sup>2</sup> to Blow clogging material free

### Energy Efficiency / Saving Measures in Compressed Air System

- Ensure air intake to compressor is not warm and humid by locating compressors in well ventilated area or by drawing cold air from outside. Every 4°C rise in air inlet temperature will increase power consumption by 1 percent.
- Clean air-inlet filters regularly. Compressor efficiency will be reduced by 2 percent for every 250 mm WC pressure drop across the filter.
- Keep compressor valves in good condition by removing and inspecting once every six months. Worn-out valves can reduce compressor efficiency by as much as 50 percent.
- Install manometers across the filter and monitor the pressure drop as a guide to replacement of element.
- Minimize low-load compressor operation; if air demand is less than 50 percent of compressor capacity, consider change over to a smaller compressor or reduce compressor speed appropriately (by reducing motor pulley size) in case of belt driven compressors.
- Consider the use of regenerative air dryers, which uses the heat of compressed air to remove moisture.
- Fouled inter-coolers reduce compressor efficiency and cause more water condensation in air receivers and distribution lines resulting in increased corrosion. Periodic cleaning of intercoolers must be ensured.
- Compressor free air delivery test (FAD) must be done periodically to check the present operating capacity against its design capacity and corrective steps must be taken if required.
- If more than one compressor is feeding to a common header, compressors must be operated in such a way that only one small compressor should handle the load variations whereas other compressors will operate at full load.
- The possibility of heat recovery from hot compressed air to generate hot air or water for process application must be economically analysed in case of large compressors.
- Consideration should be given to two-stage or multistage compressor as it consumes less power for the same air output than a single stage compressor.

### Energy Efficiency / Saving Measures in Refrigeration System

#### a) Cold Insulation

Insulate all cold lines / vessels using economic insulation thickness to minimize heat gains; and choose appropriate (correct) insulation.

#### b) Building Envelope

Optimize air conditioning volumes by measures such as use of false ceiling and segregation of critical areas for air conditioning by air curtains.

#### c) Building Heat Loads Minimization

Minimize the air conditioning loads by measures such as roof cooling, roof painting, efficient lighting, pre-cooling of fresh air by air- to-air heat exchangers, variable volume air system, optimal Thermo static setting of temperature of air-conditioned spaces, sun film applications, etc.

#### e) Process Heat Loads Minimization

Minimize process heat loads in terms of TR capacity as well as refrigeration level, i.e., temperature required, by way of:

- i) Flow optimization



## ENERGY CONSERVATION AND MANAGEMENT

- ii) Heat transfer area increase to accept higher temperature coolant
  - iii) Avoiding wastages like heat gains, loss of chilled water, idle flows.
  - iv) Frequent cleaning / de-scaling of all heat exchangers
- f) At the Refrigeration A/C Plant Area
- i) Ensure regular maintenance of all A/C plant components as per manufacturer guidelines.
  - ii) Ensure adequate quantity of chilled water and cooling water flows, avoid bypass flows by closing valves of idle equipment.
  - iii) Minimize part load operations by matching loads and plant capacity on line; adopt variable speed drives for varying process load.
  - iv) Make efforts to continuously optimize condenser and evaporator parameters for minimizing specific energy consumption and maximizing capacity.
  - v) Adopt VAR system where economics permit as a non-CFC solution.

### **Energy Efficiency / Saving Measures in A/C**

- Ensure air intake to compressor is not warm and humid by locating compressors in well ventilated area or by drawing cold air from outside. Every 4°C rise in air inlet temperature will increase power consumption by 1 percent.
- Clean air-inlet filters regularly. Compressor efficiency will be reduced by 2 percent for every 250 mm WC pressure drop across the filter.
- Keep compressor valves in good condition by removing and inspecting once every six months. Worn-out valves can reduce compressor efficiency by as much as 50 percent.
- Install manometers across the filter and monitor the pressure drop as a guide to replacement of element.
- Minimize low-load compressor operation; if air demand is less than 50 percent of compressor capacity, consider change over to a smaller compressor or reduce compressor speed appropriately (by reducing motor pulley size) in case of belt driven compressors.
- Consider the use of regenerative air dryers, which uses the heat of compressed air to remove moisture.
- Fouled inter-coolers reduce compressor efficiency and cause more water condensation in air receivers and distribution lines resulting in increased corrosion. Periodic cleaning of intercoolers must be ensured.
- Compressor free air delivery test (FAD) must be done periodically to check the present operating capacity against its design capacity and corrective steps must be taken if required.
- If more than one compressor is feeding to a common header, compressors must be operated in such a way that only one small compressor should handle the load variations whereas other compressors will operate at full load.
- The possibility of heat recovery from hot compressed air to generate hot air or water for process application must be economically analyze in case of large compressors.
- Consideration should be given to two-stage or multistage compressor as it consumes less power for the same air output than a single stage compressor.
- If pressure requirements for processes are widely different (e.g. 3 bar to 7 bar), it is advisable to have two separate compressed air systems.
- Reduce compressor delivery pressure, wherever possible, to save energy.
- Provide extra air receivers at points of high cyclic-air demand which permits operation without extra compressor capacity.
- Retrofit with variable speed drives in big compressors, say over 100 kW, to eliminate the 'unloaded' running condition altogether.

## ENERGY CONSERVATION AND MANAGEMENT

- Keep the minimum possible range between load and unload pressure settings.
- Automatic timer-controlled drain traps waste compressed air every time the valve opens. So, frequency of drainage should be optimized.
- Check air compressor logs regularly for abnormal readings, especially motor current cooling water flow and temperature, inter-stage and discharge pressures and temperatures and compressor load-cycle.
- Compressed air leakage of 40 – 50 percent is not uncommon. Carry out periodic leak tests to estimate the quantity of leakage.

### Energy Saving Opportunities in Cooling Towers

- **Reject heat to atmosphere**
- **Hot water from heat exchanger is sent to the cooling tower, water cools and exits the cooling tower and is sent back to the exchanger of other units for further cooling**
- Optimize cooling tower fan blade angle on a seasonal and/or load basis.
- Correct excessive and/or uneven fan blade tip clearance and poor fan balance.
- On old counter-flow cooling towers, replace old spray type nozzles with new square spray ABS practically non-clogging nozzles.
- Replace splash bars with self-extinguishing PVC cellular film fill.
- Install new nozzles to obtain a more uniform water pattern
- Periodically clean plugged cooling tower distribution nozzles.
- Balance flow to cooling tower hot water basins.
- Cover hot water basins to minimize algae growth that contributes to fouling.
- Optimize blow down flow rate, as per COC limit.
- Replace slat type drift eliminators with low pressure drop, self-extinguishing, PVC cellular units.
- Restrict flows through large loads to design values.
- Monitor L/G ratio, CW flow rates w.r.t. design as well as seasonal variations. It would help to increase water load during summer and times when approach is high and increase air flow during monsoon times and when approach is narrow.
- Monitor approach, effectiveness and cooling capacity for continuous optimization efforts, as per seasonal variations as well as load side variations.
- Consider COC improvement measures for water savings.
- Consider energy efficient FRP blade adoption for fan energy savings.
- Consider possible improvements on CW pumps with respect to efficiency improvement.
- Control cooling tower fans based on leaving water temperatures especially in case of small units.
- Optimize process CW flow requirements, to save on pumping energy, cooling load, evaporation losses (directly proportional to circulation rate) and blow down losses.

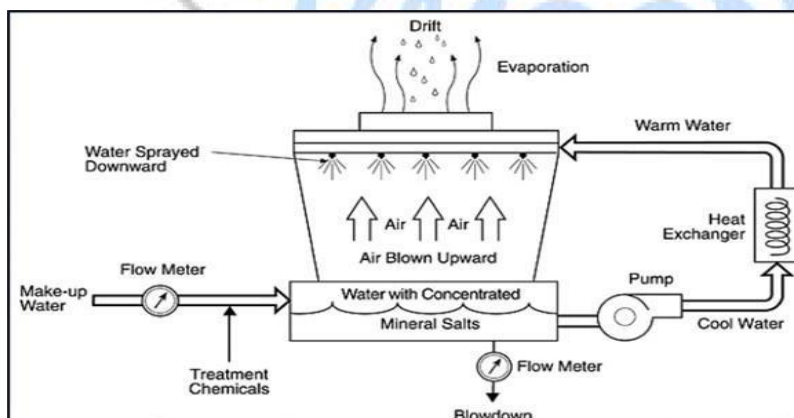

## ENERGY CONSERVATION AND MANAGEMENT

### Two main categories;

1. Natural draft; large concrete chimneys to introduce air through the media
2. Mechanical draft; large fans to force or suck air through circulated water

### COMPONENTS OF A COOLING TOWER

- Frame and casing
- Fill
- Cold wash basin
- Drift eliminator
- Air inlet
- Louvers
- Nozzles
- Fans

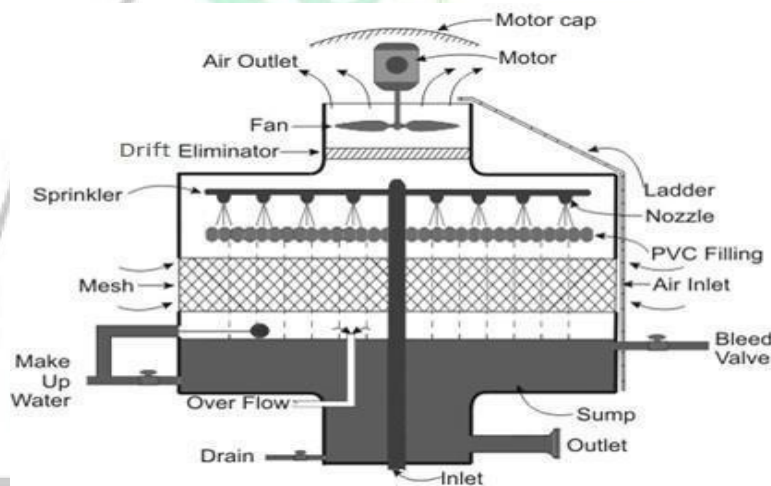

### Maintenance and upkeep of Vacuum lines and Compressed air pipe lines.

#### Vacuum pipeline maintenance

Neglecting vacuum pipelines can lead to a cascade of problems:

1. Clogged lines
2. Reduced suction
3. Increased energy consumption
4. Unpleasant odors



## ENERGY CONSERVATION AND MANAGEMENT

### Regular cleaning

- Schedule regular cleaning of inlets and pipelines to remove debris buildup.

### Filter replacements:

- Replace filters in separation units as per the manufacturer's recommendations to maintain optimal airflow and prevent dust buildup.

### Lubrication:

- Regularly lubricate moving parts like bearings and valves to prevent wear and tear

### Leak detection and repair:

- Leaks in pipelines or connections can significantly reduce suction and waste energy. Regularly inspect for leaks and repair them promptly.

### Power unit maintenance

- Follow the manufacturer's recommendations for maintaining the power unit, including regular inspections, oil changes, and belt replacements.

### Documentation:

- Keep a log of all maintenance activities performed on the system for future reference and to track potential issues.

## Importance of pipeline maintenance

Neglecting compressed air pipelines can lead to a cascade of problems:



### Regular inspection

- Visual inspection
- Leak detection
- Internal inspection

### Preventative maintenance

- Drain condensate
- Clean filters
- Lubricate joints

### Repairs and replacements

- Address leaks promptly:
- Repair or replace damaged sections
- Upgrade outdated equipment:

## Conservation and reuse of water

### CONSERVATION

- Conservation is the method that implies preserving resources in a managed time period for future use.
- Conservation is planned management of a natural resource to prevent exploitation, destruction, or neglect of the resource.
- It may more specifically be used for preserving biodiversity, environment or natural resources.
- It is done so that future generations can also have the advantage of the resources

### CONSERVATION OF WATER

## **ENERGY CONSERVATION AND MANAGEMENT**

- Water conservation refers to the preservation, management, and protection of water and its resources.
- It is a system that was put in place to manage freshwater, minimize waste, and protect water and its resources to reduce and avoid shortages.
- The key activities to conserve water are as follows:

(i) any beneficial reduction in water loss, use and waste of resources

(ii) avoiding any damage to water quality

(iii) improving water management practices that (reduce the use or enhance the beneficial use of water.

- Technology solutions exist for households, commercial and agricultural applications.
- Water conservation programs involved in social solutions are typically initiated at the local level, by either municipal water utilities or regional governments.

### **STRATEGIES**

- The key activities to conserve water are as follows:
- Any beneficial reduction in water loss, use and waste of resources. [3]
- Avoiding any damage to water quality.
- Improving water management practices that reduce the use or enhance the beneficial use of water.

(I) Rain water harvesting: Digging ponds, lakes, canals, expanding the water reservoir, and installing rain water catching ducts and filtration systems on homes are different methods of harvesting rain water.

(II) Protecting groundwater resources: When precipitation occurs, some infiltrates the soil and goes underground.

- Water in this saturation zone is called groundwater.
- Contamination of groundwater decreases the replenishment of available freshwater so taking preventative measures by protecting groundwater resources from contamination is an important aspect of water conservation.

(III) Practicing sustainable methods of utilizing groundwater resources:

- Excess pumping of groundwater leads to a decrease in groundwater levels and if continued it can exhaust the resource.
- Ground and surface waters are connected and overuse of groundwater can reduce and, in extreme examples, diminish the water supply of lakes, rivers, and streams.
- Sustainable use of groundwater is essential in water conservation.

(IV) Judicious and wise use of water for washing, and cleaning purposes.

(VI) Avoid unnecessary usage of water by ensuring that all the taps are tightly closed and no water is dripping.

(VII) Close the tap while brushing your teeth.

(VIII) Check for leaks of faucets, taps, and pipes regularly to get them repaired as soon as possible.

(IX) Do not water plants during the rainy season as plants can then absorb moisture from the air

### **REUSE OF WATER**

- Water reuse generally refers to the process of using treated wastewater (reclaimed water) for beneficial purposes such as agricultural and landscape irrigation, industrial processes, nonportable urban applications (such as toilet flushing, street washing, and fire protection), groundwater recharge, recreation, and direct or undirected water supply.



## ENERGY CONSERVATION AND MANAGEMENT

- Its increased application has been facilitated by modern wastewater treatment processes that have advanced substantially during the twentieth century.
- These processes can now effectively remove biodegradable materials, nutrients, and pathogens, so the treated water has a wide range of potential applications.

### What Water Can We Reuse?

<b>RAINWATER</b>	From rain or snow collected directly from roof surfaces	
<b>STORMWATER</b>	From rain or snow that falls on and runs off the land	
<b>GRAYWATER</b>	From showers, bathroom sinks, and washing machines	
<b>WASTEWATER</b>	From toilets & kitchen sinks in homes and businesses. Usually includes gray water and can include industrial water.	
<b>Industrial &amp; Commercial</b>	From building foundation collection systems, food processing, and other industrial sources.	

Sources & Attributions: Adapted from Minnesota Dept. Of Health. IAN Image Library  
<http://icons.iconarchive.com> (Rainwater), <http://moziru.com> (Stormwater),  
<http://icons.iconarchive.com> (gray, wastewater, industry)

### What Water Can We Reuse?

<b>RAINWATER</b>	From rain or snow collected directly from roof surfaces	
<b>STORMWATER</b>	From rain or snow that falls on and runs off the land	
<b>GRAYWATER</b>	From showers, bathroom sinks, and washing machines	
<b>WASTEWATER</b>	From toilets & kitchen sinks in homes and businesses. Usually includes gray water and can include industrial water.	
<b>Industrial &amp; Commercial</b>	From building foundation collection systems, food processing, and other industrial sources.	

Sources & Attributions: Adapted from Minnesota Dept. Of Health. IAN Image Library  
<http://icons.iconarchive.com> (Rainwater), <http://moziru.com> (Stormwater),  
<http://icons.iconarchive.com> (gray, wastewater, industry)

## WAYS TO USE REUSE OF WASTE WATER

### (I). Agricultural Wastewater Reuse:

- Wastewater can be used for agricultural purposes like watering landscaped gardens and lawns.
- But then, irrigation must still be done according to the WHO (1989) guidelines for the safe use of wastewater in agriculture by monitoring the water contaminant levels of wastewater.

Otherwise, humans and animals may consume contaminants from the crops, which is not good for health.

### (II) Trap Rainwater:



## ENERGY CONSERVATION AND MANAGEMENT

- Collecting rainwater is equally part of water reuse that many people do not recognize. Installing gutters for diverting rainwater to where it can be stored does the work.
- After collection, the water can be used in the garden to water plants, car-washing, for laundry, and for many other purposes, as rainwater is considered clean and safe compared to other types of used water, such as greywater.

(III) Reuse water used to wash fruits and vegetables:

- This used water from washing fruits and veggies can be collected and reused for watering potted plants and gardens. Similarly, rinse water from utensils can also be saved and used for cleaning sinks, floors, and toilets.

(V) Collect rainwater when it rains:

- Collecting and using rainwater will help refill earth's depleting ground water reservoirs

## Water Auditing

- Water auditing is a method of quantifying water flows and quality in simple or complex systems, with a view to reducing water usage and often saving money on otherwise unnecessary water use.
- There is an increasing awareness around the globe of the centrality of water to our lives.
- This awareness crosses political and social boundaries. In many places people have difficult access to drinking water. Often it is polluted. Water auditing is a mechanism for conserving water, which will grow in significance in the future as demand for water increases.
- There is a strong relationship of water auditing with associated activities like environmental auditing, environmental management systems, resource conservation, flow measurement, water quality and legal frameworks.
- Typical applications (arenas) in which water auditing are conducted include buildings (interior and exterior), landscape, external commercial applications requiring irrigation, aquatic centres, material transport by water, cooling systems and non-metal manufacturing (e.g. paper manufacture).

## Tips for Reducing Energy Consumption in Food Manufacturing

### 1. Automate, monitor and control.

The food and beverage industry can use existing automating, monitoring and controlling processes to conserve energy, such as:

1. Setting specific energy goals. This step alone will lead to a reduction in energy consumption in different areas of the business
2. Using new technology to monitor kilowatt consumption, optimize equipment utilization and build a robust control process to synchronize the system with plant operations

### 2. Improve efficiency of refrigeration and temperature controlled systems.

Refrigeration and chilling can account for between 30 and 80 percent of energy use. Specific ways to improve efficiencies in this area include:

1. Using more efficient heat exchangers
2. Using the most suitable refrigerant system with the highest efficiency rating
3. Implementing a robust maintenance system to include leak detection, cleaning and optimal thermal set points

### 3. Consider using variable speed drives (VSD) and motors.

### 4. Use alternative energy systems and sources where possible.

## ENERGY CONSERVATION AND MANAGEMENT

The use of low power factor equipment and other devices that provide sustainable power to plant operations can result in huge savings. Think fuel cell technologies, solar panels and wind power.

### 5. Employ energy-efficient lighting systems.

- LED lighting consumes less, requires less maintenance and is cooler and brighter. Such systems are becoming more attractive in cost while increasing efficiency.

### 6. Implement a culture of energy efficiency.

- Conduct training sessions to discuss best energy practices and educate operators about how to make better decisions.
- Educate all stakeholders about the importance of energy conservation and provide specific steps about how they can integrate these best practices into their daily routines

## Energy conservation opportunity in wastewater treatment

### Introduction

- Treating wastewater is an energy-intensive and costly process, and a large source of both direct and indirect greenhouse gas emissions through energy use and release of methane and other gases.
- Wastewater treatment plants (WWTPs) are also custodians of a biological process that can produce renewable energy, in some cases sufficient to supply all of a plant's energy needs
- Energy prices rising and the cost of electricity for WWTPs a significant portion of a plant's total operating costs (typically 25–50%)
- Typical wastewater-treatment plants — both industrial and municipal — consume large amounts of energy, which can represent 50% or more of the facility's variable operating and maintenance costs.
- Most employ biological processes that rely on energy-intensive aeration systems whose energy consumption is approximately 0.5 kWh per m<sup>3</sup> of effluent treated.
- The specific energy-conservation options available are
  - Optimize aeration and oxygen transfer
  - Use variable frequency drives (VFDs) to adjust the speed of electric motors to meet process demand
  - Replace old electric motors with more-energy-efficient ones
  - Maximize the production and use of biogas as a fuel

### Potential energy cost savings in WWTP

Up to 90% of energy consumption in WWTPs occurs in these three processes: There are three main ways to reduce energy costs at WWTPs:

1. Reduce overall energy consumption through efficiency
2. Generate power on site (e.g. using solar photovoltaics [PV] or biogas)
3. Better manage energy supply and demand (e.g. power factor correction).

### Reduce your electricity costs



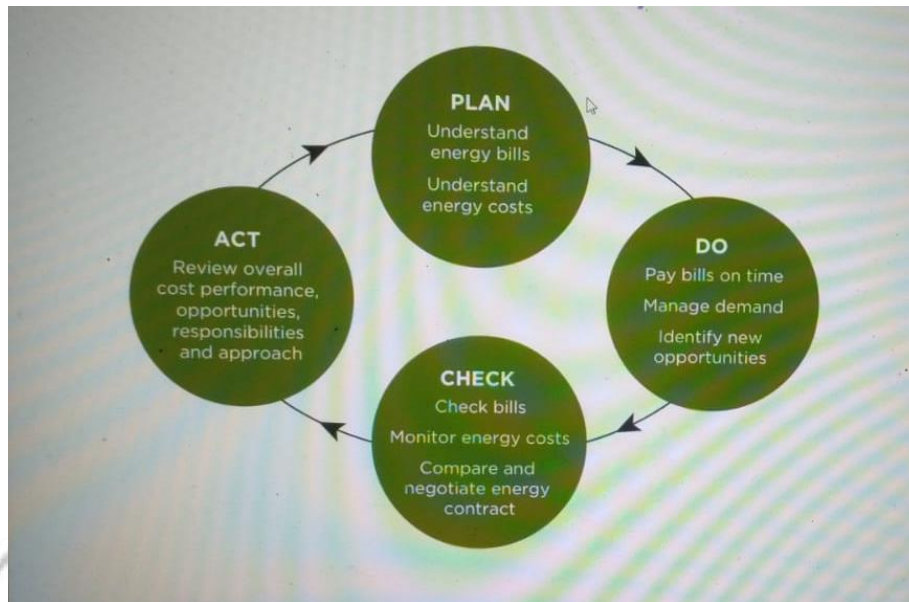

### Optimise aeration and blower system

- The main purpose of aeration is to provide oxygen to biological processes in activated sludge systems.
- Three components: airflow generation by blowers, airflow distribution, and aeration tanks categorised as surface or sub-surface systems.
- The sub-surface systems include coarse-bubble and fine-bubble diffusion or jet aeration. Surface systems include fixed or floating surface aerators and a range of paddle-type (e.g. 'brush') aerators

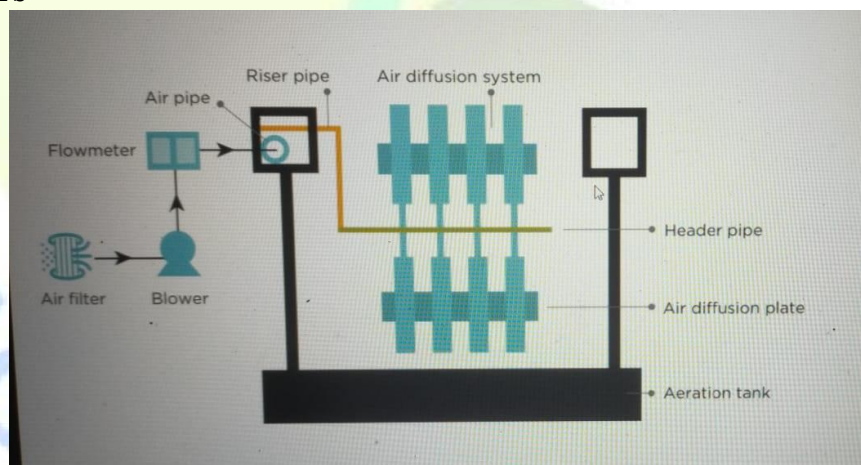

### Optimise pumping

- Pumping systems at WWTPs can typically account for 30–50% of total energy consumption.
- Factors—the difference between pump inlet and outlet pressure, flow rate, operating hours and overall efficiency.

PDCA framework:



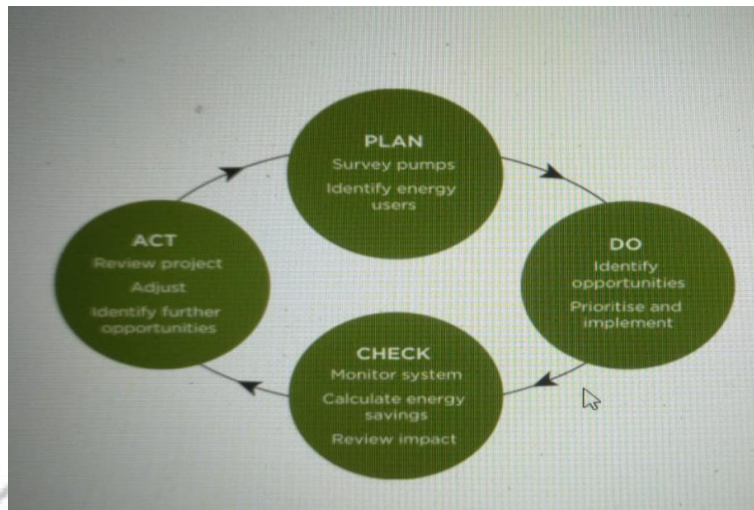

### Generate heat and power from biosolids

Biogas, produced by anaerobic digestion of biosolids, is a valuable source of energy

#### Benefits

- Disposal of wet biosolids no longer required<sup>27</sup>
- Onsite generation of renewable power, with significantly lower greenhouse gas emissions<sup>28</sup>
- Reduced dependency on electrical power from the network (and exposure to retail price fluctuations)
- The biosolids 'ash' may be a valuable fertiliser – an additional revenue source

## Lesson 5

## ELECTRICAL SYSTEM

## Introduction to Electric Power Supply Systems

Electric power supply system comprises of generating units that produce electricity; high voltage transmission lines that transport electricity over long distances; distribution lines that deliver the electricity to consumers; substations that connect the pieces to each other, and energy control centers to coordinate the operation of the components.

The Figure 1.1 shows a simple electric supply system with Generating Station, Power transmission and distribution network and linkages from electricity sources to end-user.

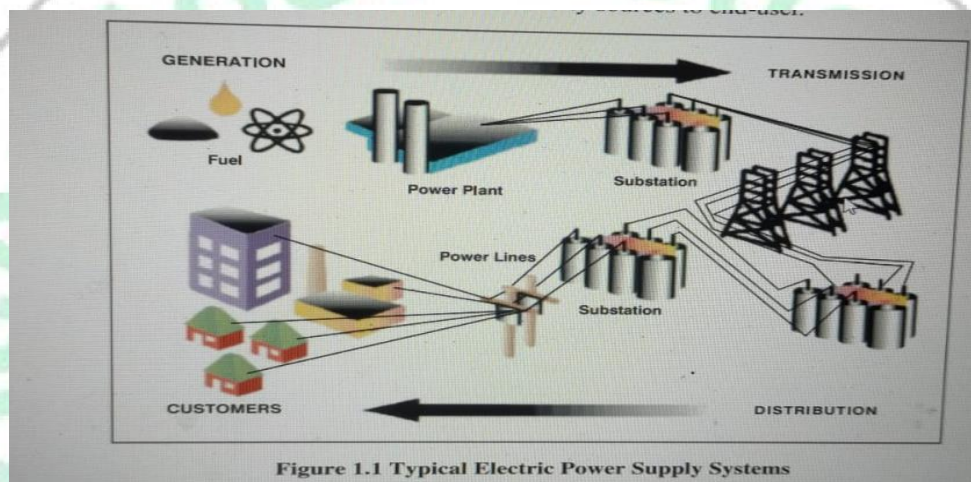

Figure 1.1 Typical Electric Power Supply Systems

## Power Generation Plant

The fossil fuels such as coal, oil and natural gas, nuclear energy, and falling water (hydel) are commonly used energy sources in the power generating plant. A wide and growing variety of unconventional generation technologies and fuels have also been developed, including cogeneration, solar energy, wind generators, and waste materials.

About 70% of power generating capacity in India is from coal based thermal power plants. The principle of coal-fired power generation plant is shown in Figure. Energy stored in the coal is converted into electricity in a thermal power plant. Coal is pulverized to the consistency of talcum powder. Then powdered coal is blown into the water wall boiler where it is burned at temperature higher than  $1300^{\circ}\text{C}$ . The heat in the combustion gas is transferred into steam. This high-pressure steam is used to spin the steam turbine. Finally, turbine rotates the generator to produce electricity.

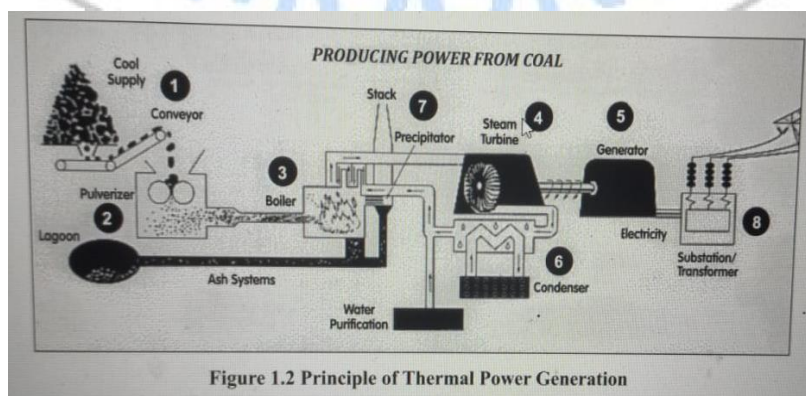

Figure 1.2 Principle of Thermal Power Generation



## ENERGY CONSERVATION AND MANAGEMENT

In India, for the coal-based power plants, the overall efficiency ranges from 28% to 35% depending upon the size, operational practices, fuel quality and capacity utilization. Where fuels are the source of generation, a common term used is the "HEAT RATE" which reflects the efficiency of generation. "HEAT RATE" is the heat input in kilo Calories or kilo Joules, for generating 'one' kilo Watt-hour of electrical output. One kilo Watt hour of electrical energy being equivalent to 860 kilo Calories of thermal energy or 3600 kilo Joules of thermal energy. The "HEAT RATE" is inversely proportional to efficiency of power generation i.e., lower the heat rate, higher is the generation efficiency.

### Transmission and Distribution Lines:

A The power plants typically produce 50 cycle/second (Hertz), alternating-current (AC) electricity with voltages between 11kV and 33kV. At the power plant site, the 3-phase voltage is stepped up to a higher voltage for transmission on cables strung on cross- country towers. High voltage (HV) and extra high voltage (EHV) transmission is the next stage from power plant to transport A.C. power over long. distances at voltages like; 220 kV & 400 kV (Figure). Where transmission is over 1000 KM, high voltage direct current transmission is also favoured to minimize the losses.

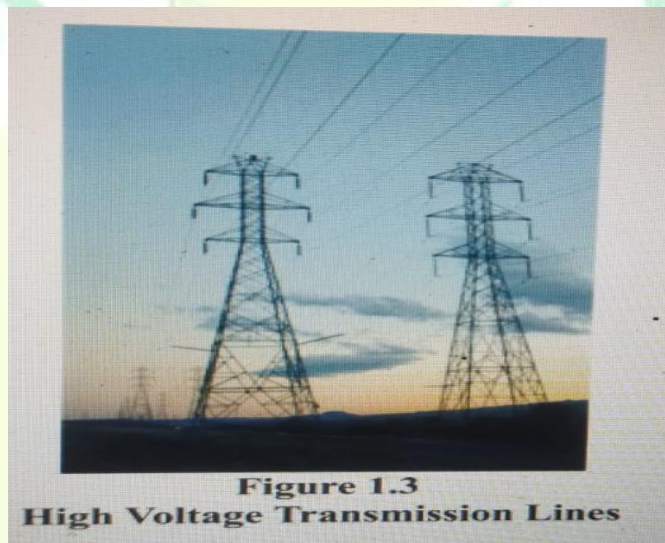

### Electricity Billing - HT Supply

The electricity billing by utilities for medium & large enterprises, in High Tension (HT) category, is often done on two-part tariff structure, i.e. one part for capacity (or demand) drawn and the second part for actual energy drawn during the billing cycle. Capacity or demand is in kVA (apparent power) or kW terms. The reactive energy (i.e.) kVArh drawn by the service is also recorded and billed for in some utilities, because this would affect the load on the utility.

Accordingly, utility charges for maximum demand, active energy and reactive power drawn (as reflected by the power factor) in its billing structure. In addition, other fixed and variable expenses are also levied.

### The Tariff Structure of HT Electricity Billing

The tariff structure of HT supply generally includes the following components:

#### a) Maximum demand Charges

These charges relate to maximum demand registered during month/billing period and corresponding rate of utility.

#### b) Energy Charges

These charges relate to energy (kilowatt hours) consumed during month / billing period and corresponding rates, often levied in slabs of use rates. Some utilities now charge on the basis of apparent energy (kVAh), which is a vector sum of kWh and kVArh.



## ENERGY CONSERVATION AND MANAGEMENT

### c) **Power factor**

Power factor penalty or bonus rates, as levied by most utilities, are to contain reactive power drawn from grid.

### d) **Fuel cost**

Fuel cost adjustment charges as levied by some utilities are to adjust the increasing fuel expenses over a base reference value.

### e) **Electricity duty charges**

Electricity duty charges levied w.r.t units consumed.

### f) **Meter rentals**

### g) **Lighting and fan power consumption**

Lighting and fan power consumption is often at higher rates, levied sometimes on slab basis or on actual metering basis.

### h) **Time of Day (TOD)**

Time of Day (TOD) rates like peak and non-peak hours are also prevalent in tariff structure provisions of some utilities.

### i) **Penalty for exceeding contract demand**

#### **Electricity Billing - LT Supply**

The electricity billing by utilities for LT category, is often done on one-part tariff structure, i.e. billing is done for actual energy drawn during the billing cycle.

#### **The Tariff Structure of LT Electricity Billing**

The tariff structure of LT supply generally includes the following components:

### a) **Energy Charges**

These charges relate to energy (kilowatt hours) consumed during month / billing period and corresponding rates, often levied in slabs of use rates. Some utilities now charge on the basis of apparent energy (kVAh), which is a vector sum of kWh and kVArh.

### b) **Meter rentals**

### c) **Surcharge if metering is at LT side in some of the utilities**

#### **Transformers**

A transformer can accept energy at one voltage and deliver it at another voltage. This permits electrical energy to be generated at relatively low voltages and transmitted at high voltages and low currents, thus reducing line losses and voltage drop (see Figure).



Figure View of a Transformer

Transformers consist of two or more coils that are electrically insulated, but magnetically linked. The primary coil is connected to the power source and the secondary coil connects to the load. The turn's ratio is the ratio between the number of turns on the secondary to the turns on the primary (See Figure).

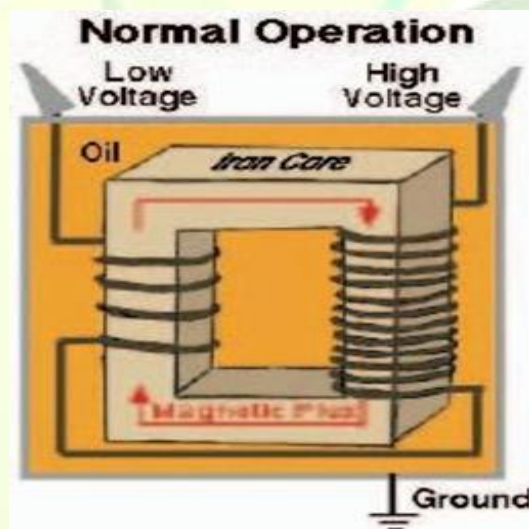

Figure Transformer Coil

The secondary voltage is equal to the primary voltage times the turn's ratio. Ampere-turns are calculated by multiplying the current in the coil times the number of turns. Primary ampere- turns are equal to secondary ampere-turns. Voltage regulation of a transformer is the percent increase in voltage from full load to no load.

### Types of Transformers

Transformers are classified as two categories: power transformers and distribution transformers.

Power transformers are used in transmission network of higher voltages, deployed for step-up and step-down transformer application (400 kV, 200 kV, 110 kV, 66 kV, 33kV)

Distribution transformers are used for lower voltage distribution networks as a means to end user connectivity. (11kV, 6.6 kV, 3.3 kV, 440V, 230V)

### Rating of Transformer

Rating of the transformer is calculated based on the connected load and applying the diversity factor on the connected load, applicable to the particular industry and arrive at the kVA rating of the Transformer. Diversity factor is defined as the ratio of overall maximum demand of the plant to the sum of individual maximum demand of various equipment's. Diversity factor varies from

## ENERGY CONSERVATION AND MANAGEMENT

industry to industry and depends on various factors such as individual loads, load factor and future expansion needs of the plant. Diversity factor will always be less than one.

### Location of Transformer

Location of the transformer is very important as far as distribution loss is concerned. Transformer receives HT voltage from the grid and steps it down to the required voltage. Transformers should be placed close to the load centre, considering other features like optimization needs for centralized control, operational flexibility etc. This will bring down the distribution loss in cables.

### Transformer Losses and Efficiency

The efficiency varies anywhere between 96 to 99 percent. The efficiency of the transformers not only depends on the design, but also, on the effective operating load.

Transformer losses consist of two parts: No-load loss and Load loss

**1.No-load loss (also called core loss)** is the power consumed to sustain the magnetic field in the transformer's steel core. Core loss occurs whenever the transformer is energized; core loss does not vary with load. Core losses are caused by two factors: hysteresis and

eddy current losses. Hysteresis loss is that energy lost by reversing the magnetic field in the core as the magnetizing AC rises and falls and reverses direction. Eddy current loss is a result of induced currents circulating in the core.

**2.Load loss (also called copper loss)** is associated with full-load current flow in the transformer windings. Copper loss is power lost in the primary and secondary windings of a transformer due to the ohmic resistance of the windings. Copper loss varies with the square of the load current. ( $P = I^2R$ ).

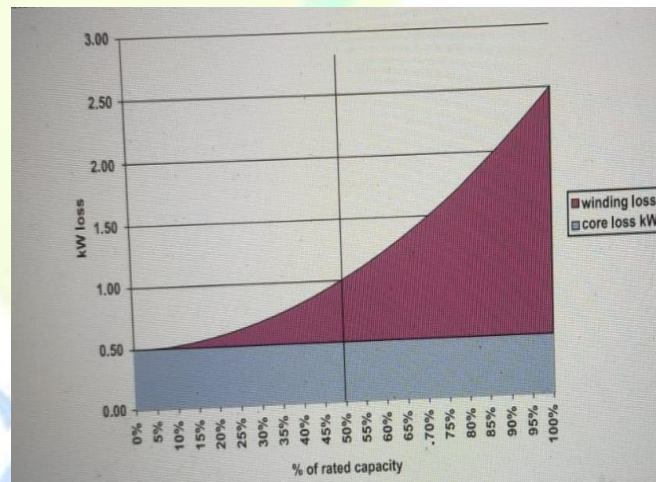

Transformer loss vs %Load

For a given transformer, the manufacturer can supply values for no-load loss, PNO-LOAD, and load loss, PLOAD the total transformer loss, PTOTAL, at any load level can then be calculated from:

$$PTOTAL = PNO-LOAD + (\% \text{ Load} / 100)^2 \times PLOAD$$

Where transformer loading is known, the actual transformers loss at given load can be computed as:

$$= \text{No load loss} + (\text{KVA load} / \text{Rated KVA})^2 \times (\text{Full load loss})$$



## ENERGY CONSERVATION AND MANAGEMENT

### Parallel Operation of Transformers

The design of Power Control Centre (PCC) and Motor Control Centre (MCC) of any new plant should have the provision of operating two or more transformers in parallel. Additional switchgears and bus couplers should be provided at design stage.

Whenever two transformers are operating in parallel, both should be technically identical in all aspects and more importantly should have the same impedance level. This will minimize the circulating current between transformers.

Where the load is fluctuating in nature, it is preferable to have more than one transformer running in parallel, so that the load can be optimized by sharing the load between transformers. The transformers can be operated close to the maximum efficiency range by this operation.

For operating transformers in parallel, the transformers should have the following principal characteristics.

The same phase angle difference between the primary and secondary terminals.

- Same voltage ratio
- Same percentage impedance
- Same polarity
- Same phase sequence

### Energy Efficient Transformers

Most energy loss in dry-type transformers occurs through heat or vibration from the core. The new high-efficiency transformers minimize these losses. The conventional transformer is made up of a silicon alloyed iron (grain oriented) core. The iron loss of any transformer depends on the type of core used in the transformer. However, the latest technology is to use amorphous material - a metallic glass alloy for the core (see Figure). The expected reduction in core loss over conventional (Si Fe core) transformers is roughly **around 70%**, which is quite significant. By using an amorphous core- with unique physical and magnetic properties- these new types of **transformers have increased efficiency even at low loads - 98.5% efficiency at 35% load.**

Electrical distribution transformers made with amorphous metal cores provide excellent opportunity to conserve energy right from the installation. Though these transformers are a little costlier than conventional iron core transformers, the overall benefit towards energy savings will compensate for the higher initial investment.



Figure 1.17 1600 kVA Amorphous Core Transformer

**Assessment of Transmission and Distribution (T&D) Losses in Power Systems**

For an electric utility (DISCOMs) the distribution losses which are more predominant, can be categorized as

- i) Technical Losses
- ii) Commercial Losses

**Technical Losses:**

The technical losses primarily take place due to the following factors

- Transformation Losses (at various transformation levels)
- High FR losses in distribution lines due to inherent resistance and poor power factor in the electrical network

Normative Technical loss limits in Indian Transmission and Distribution network are shown in Table 1.6.

Table 1.6 Normative Technical loss limits in Transmission and Distribution network in Indian Context

System Component	Loss Limit %	
	Min	Max
STEP-UP Transformers & EHV Transmission System	0.5	1.0
Transmission to intermediate voltage level, transmission system & Step-down to sub transmission Voltage level	1.5	3.0
Sub transmission System & step down to distribution voltage level	2.0	4.5
Distribution lines and Service connections	3.0	7.0
<b>Total Losses</b>	<b>7.0</b>	<b>15.5</b>

**Estimation of Technical Losses in Distribution System**

The first and important step in reduction of energy losses is to carry out energy audit of power distribution system. There are two methods of determining the energy losses namely direct method and indirect method.

**The Direct method** involves placement of energy meters at all locations starting from the input point of the feeder to the individual consumers. The difference between input energy and sum of all consumers over a specific duration is accounted as distribution loss of the network. This calls for elaborate and accurate metering and collection of simultaneous data.

**The Indirect method** essentially involves:

- Energy metering at critical locations in the system such as substation and feeders.
- Compiling the network information, such as length of the line/feeders, conductor size, DTR details, capacitor details etc.
- Conducting load flow studies (all electrical parameters) on peak load durations as well as normal load durations.
- Application of suitable software to assess the system losses.

This software can also be used for system simulation, identifying improvements and network optimization.



**Power Factor Improvement and Benefits****1. Power factor Basics**

In all industrial electrical distribution systems, the major loads are resistive and inductive. Resistive loads are incandescent lighting and resistance heating. In case of pure resistive loads, the voltage (V), current (I), resistance (R) relations are linearly related, i.e.

$$V = I \times R \quad \text{and} \quad \text{Power (kW)} = V \times I$$

Typical inductive loads are A.C. Motors, induction furnaces, transformers and ballast- type lighting. Inductive loads require two kinds of power: a) active (or working) power to perform the work and b) reactive power to create and maintain electro-magnetic fields.

Active power is measured in kW (Kilo Watts). Reactive power is measured in kVAr (Kilo Volt-Amperes Reactive).

The vector sum of the active power and reactive power make up the total (or apparent) power used. This is the power generated by the SEBs for the user to perform a given amount of work. Total Power is measured in kVA (Kilo Volts-Amperes) (See Figure).

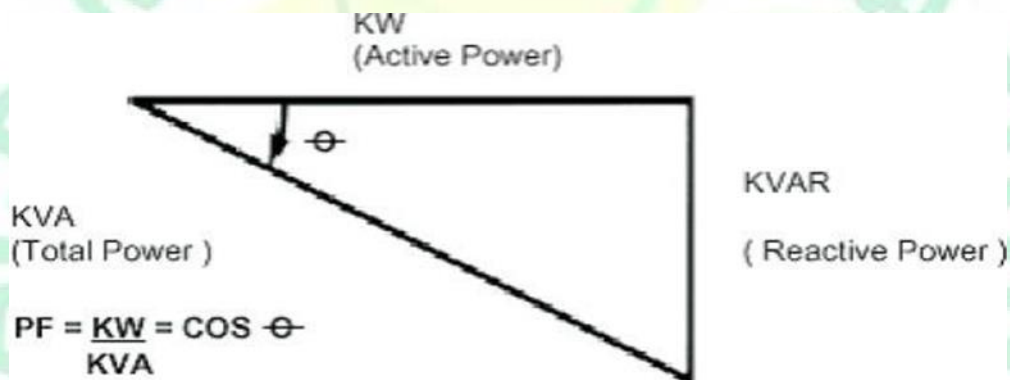

Fig Power Triangle

The active power (shaft power required or true power required) in kW and the reactive power required (kVA) are 90° apart vectorially in a pure inductive circuit i.e., reactive power kVA lagging the active kW. The vector sum of the two is called the apparent power or kVA, as illustrated above and the kVA reflects the actual electrical load on distribution system.

The ratio of kW to kVA is called the power factor, which is always less than or equal to unity. Theoretically, when electric utilities supply power, if all loads have unity power factor, maximum power can be transferred for the same distribution system capacity. However, as the loads are inductive in nature, with the power factor ranging from 0.2 to 0.9, the electrical distribution network is stressed for capacity at low power factors.

**2. Improving Power Factor**

The solution to improve the power factor is to add power factor correction capacitors to the plant power distribution system. They act as reactive power generators, and provide the needed reactive power to accomplish kW of work. This reduces the amount of reactive power, and thus total power, generated by the utilities.

**3. The advantages of PF improvement by capacitor addition**

- Reactive component of the network is reduced and so also the total current in the system from the source end.
- $I^2R$  power losses are reduced in the system because of reduction in current.
- Voltage level at the load end is increased.



## ENERGY CONSERVATION AND MANAGEMENT

- kVA loading on the source generators as also on the transformers and lines up to the capacitors reduces giving capacity relief. A high-power factor can help in utilizing the full capacity of your electrical system.

### 4. Cost benefits of PF improvement

While costs of PF improvement are in terms of investment needs for capacitor addition the benefits to be quantified for feasibility analysis are:

- Reduced kVA (Maximum demand) charges in utility bill
- Reduced distribution losses (KWH) within the plant network
- Better voltage at motor terminals and improved performance of motors
- A high-power factor eliminates penalty charges imposed when operating with a low power factor
- Investment on system facilities such as transformers, cables, switchgears etc for delivering load is reduced.

### 5. Direct relation for capacitor sizing

$$\text{kVAr Rating} = \text{kW} [\tan \Phi_1 - \tan \Phi_2]$$

Where kVAr rating is the size of the capacitor needed, kW is the average power drawn,  $\tan \phi_1$  is the trigonometric ratio for the present power factor, and  $\tan \phi_2$  is the trigonometric ratio for the desired PF.

$$\Phi_1 = \text{Existing (Cos-1 PF1)} \quad \text{and} \quad \Phi_2 = \text{Improved (Cos-1 PF2)}$$

### 6. Location of Capacitors

The primary purpose of capacitors is to reduce the maximum demand. Additional benefits are derived by capacitor location. The indicates typical capacitor locations. Maximum benefit of capacitors is derived by locating them as close as possible to the load. At this location, its kVAr are confined to the smallest possible segment, decreasing the load current. This, in turn, will reduce power losses of the system substantially. Power losses are proportional to the square of the current. When power losses are reduced, voltage at the motor increases; thus, motor performance also increases.

From energy efficiency point of view, capacitor location at receiving substation only helps the utility in loss reduction. Locating capacitors at tail end will help to reduce loss reduction within the plant's distribution network as well and directly benefit the user by reduced consumption. Reduction in the distribution loss % in kWh when tail end power factor is raised from PF1 to a new power factor PF2, will be proportional to

$$\left[ 1 - \left( \frac{\text{PF}_1}{\text{PF}_2} \right)^2 \right] \times 100$$

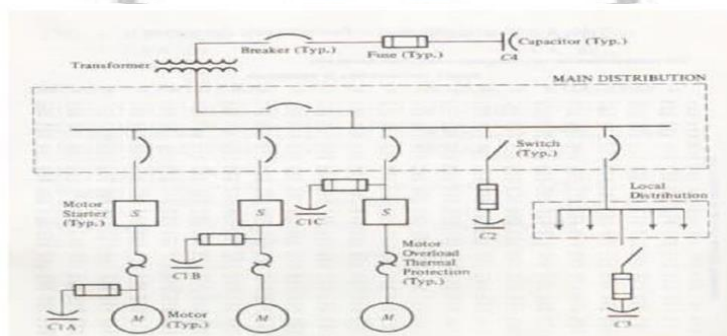

## Lesson 6

### ELECTRIC MOTORS

#### Introduction

Motors convert electrical energy into mechanical energy by the interaction between the magnetic fields set up in the stator and rotor windings. Industrial electric motors can be broadly classified as induction motors, direct current motors or synchronous motors. All motor types have the same four operating components, stator (stationary windings), rotor (rotating windings), bearings, and frame (enclosure)

#### Motor Types

##### 1. Induction Motors

An AC induction motor (Figure) has a fixed outer portion, called the stator and a rotor that spins inside with a carefully engineered air gap between the two.

If a 3-phase supply is fed to the stator windings of a 3-phase motor, a magnetic flux of constant magnitude, rotating at synchronous speed is set up. At this point, the rotor is stationary. The rotating magnetic flux passes through the air gap between the stator & rotor and sweeps past the stationary rotor conductors. This rotating flux, as it sweeps, cuts the rotor conductors, thus causing an emf to be induced in the rotor conductors. As per the Faraday law of electromagnetic induction, it is this relative motion between the rotating magnetic flux and the stationary rotor conductors, which induces an e.m.f on the rotor conductors. Since the rotor conductors are shorted and form a closed circuit, the induced e.m.f produces a rotor current whose direction is given by **Lenz's Law**, is such as to oppose the cause producing. In this case, the cause which produces the rotor current is the relative motion between the rotating magnetic flux and the stationary rotor conductors. Thus, to reduce the relative speed, the rotor starts to rotate in the same direction as that of the rotating flux on the stator windings, trying to catch it up. The frequency of the induced e.m.f is same as the supply frequency

The magnetic field produced in the rotor because of the induced voltage is alternating in nature. To reduce the relative speed, with respect to the stator, the rotor starts running in the same direction as that of the stator flux and tries to catch up with the rotating flux. However, in practice, the rotor never succeeds in **"catching up"** to the stator field. The rotor runs slower than the speed of the stator field.

The ends of the rotor bars are shorted together by rings at each end of the rotor. There is no external electrical connection to the rotor. The bar and ring structure look like an exercise wheel for a pet squirrel.



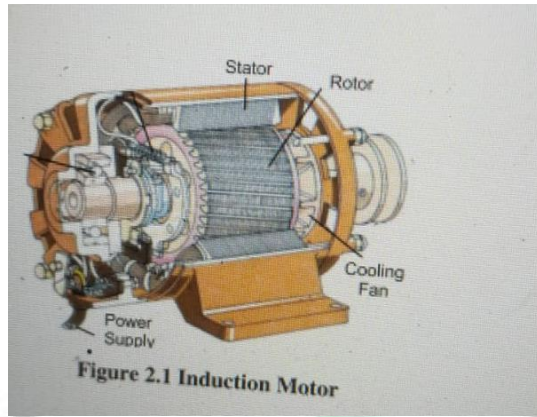

## 2.Slip-ring motor

The slip-ring motor or wound-rotor motor is a variation of the squirrel cage induction motor. While the stator is the same as that of the squirrel cage motor, the rotor of a slip-ring motor is wound with wire coils. The ends of the windings are connected to slip rings so that resistors or other circuitry can be inserted in series with the rotor coils through carbon brushes that slide on the slip-rings allowing an electrical connection with the rotating coils. This basically is the difference in construction between a squirrel cage and slip-ring motors. These are helpful in adding external resistors and contactors. The slip necessary to generate the maximum torque (pull-out torque) is directly proportional to the rotor resistance. In the slip-ring motor, the effective rotor resistance is increased by adding external resistance through the slip rings. Thus, it is possible to get higher slip and hence, the pull-out torque at a lower speed. A particularly high resistance can result in the pull-out torque occurring at almost zero speed, providing a very high pull-out torque at a low starting current. As the motor accelerates, the value of the resistance can be reduced, altering the motor characteristic to suit the load requirement. Once the motor reaches the base speed, external resistors are removed from the rotor. This means that now the motor is working as the standard induction motor.

This motor type is ideal for very high inertia loads, where it is required to generate the pull-out torque at almost zero speed and accelerate to full speed in the minimum time with minimum current draw.

Modifying the speed torque curve by altering the rotor resistors, the speed at which the motor will drive a particular load can be altered. At full load the speed can be reduced effectively to about 50% of the motor synchronous speed, particularly when driving variable torque/variable speed loads, such as printing presses, compressors, conveyer belts, hoists and elevators. Reducing the speed below 50%, results in very low efficiency due to higher power dissipation in the rotor resistances. This type of motor is used in applications for driving variable torque/ variable speed loads. **3.Direct-Current Motors**

Direct-Current motors, as the name implies, use direct-unidirectional, current. Direct current motors are used in special applications- where high torque starting or where smooth acceleration over a broad speed range is required.

## 4.Synchronous Motors

AC power is fed to the stator of the synchronous motor. The rotor is fed by DC from a separate source. The rotor magnetic field locks onto the stator rotating magnetic field and rotates at the same speed. The speed of the rotor is a function of the supply frequency and the number of magnetic poles in the stator. While induction motors rotate with a slip, i.e., rpm is less than the synchronous speed, the synchronous motor rotate with no slip, i.e., the RPM is same as the synchronous speed governed by supply frequency and number of poles. The slip energy is provided by the D.C. excitation power.



**Motor Characteristics****1. Motor Speed**

The speed of a motor is the number of revolutions in a given time frame, typically revolutions per minute (RPM). The speed of an AC motor depends on the frequency of the input power and the number of poles for which the motor is wound. The synchronous speed in RPM is given by the following equation, where the frequency is in hertz or cycles per second:

$$\text{Synchronous Speed (RPM)} = 120 \times \text{Frequency} / \text{No. of Poles}$$

Indian motors have synchronous speeds like 3000/1500/1000/750/600/500/375 RPM corresponding to no. of poles being 2, 4, 6, 8, 10, 12, 16 (always even) and given the mains frequency of 50 cycles/sec.

The actual speed, with which the motor operates, will be less than the synchronous speed. The difference between synchronous and full load speed is called slip and is measured in percent. It is calculated using this equation:

$\text{Slip (\%)} = (\text{Synchronous Speed} - \text{Full Load Rated Speed}) \times 100 / \text{Synchronous Speed}$  As per relation stated above, the speed of an AC motor is determined by the number of motor poles and by the input frequency. It can also be seen that theoretically speed of an AC motor can be varied infinitely by changing the frequency. Manufacturer's guidelines should be referred for practical limits to speed variation. With the addition of a Variable Frequency Drive (VFD), the speed of the motor can be decreased as well as increased.

**2. Power Factor**

The power factor of the motor is given as:  $\text{Power Factor} = \cos \Phi = kW/kVA$

As the load on the motor comes down, the magnitude of the **active current reduces**. However, there is no corresponding reduction in the **magnetizing current**, which is proportional to supply voltage with the result that the motor power factor reduces, with a reduction in applied load. Induction motors, especially those operating below their rated capacity, are the main reason for low power factor in electric systems.

**3. Motor Efficiency**

Two important attributes relating to efficiency of electricity use by **A.C. Induction motors are efficiency ( $\eta$ )**, defined as the ratio of the mechanical energy delivered at the rotating shaft to the electrical energy input at its terminals, and power factor (PF). Motors, like other inductive loads, are characterized by power factors less than one. As a result, the total current draw needed to deliver the same real power is higher than for a load characterized by a higher PF. An important effect of operating with a PF less than one is that resistance losses in wiring upstream of the motor will be higher, since these are proportional to the square of the current. Thus, both a high value for  $\eta$  and a PF close to unity are desired for efficient overall operation in a plant.

Squirrel cage motors are normally more efficient than slip-ring motors, and higher-speed motors are normally more efficient than lower-speed motors. Efficiency is also a function of motor temperature. Totally-enclosed, fan-cooled (TEFC) motors are more efficient than screen protected, drip-proof (SPDP) motors. Also, as with most equipment, motor efficiency increases with the rated capacity.

The efficiency of a motor is determined by intrinsic losses that can be reduced only by changes in motor design. Intrinsic losses are of two types: **fixed losses**- independent of motor load, and **variable losses dependent on load**.

**4.Fixed losses** consist of magnetic core losses and friction and windage losses. Magnetic core losses (sometimes called iron losses) consist of eddy current and hysteresis losses in the stator. They vary with the core material and geometry and with input voltage.

## ENERGY CONSERVATION AND MANAGEMENT

Friction and windage losses are caused by friction in the bearings of the motor and aerodynamic losses associated with the ventilation fan and other rotating parts.

**5.Variable losses** consist of resistance losses in the stator and in the rotor and miscellaneous stray losses. Resistance to current flow in the stator and rotor result in heat generation, that is proportional to the resistance of the material and the square of the current (IR). Stray losses arise from a variety of sources and are difficult to either measure directly or to calculate, but are generally proportional to the square of the rotor current.

**Field Tests for Determining Efficiency**

The efficiency of the motor is given by

$$\eta = \frac{P_{out}}{P_{in}} = 1 - \frac{P_{loss}}{P_{in}}$$

Where  $P_{out}$  = Output power of the motor  
 $P_{in}$  = Input power of the motor  
 $P_{loss}$  = Losses occurring in motor

The various losses in the motor are determined as follows:

**No Load Test:** The motor is run at rated voltage and frequency without any shaft load. Input power, current, frequency and voltage are noted. The no load P.F. is quite low and hence low PF watt meters are required. From the input power, stator I<sup>2</sup>R losses under no load are subtracted to give the sum of Friction and Windage (F&W) and core losses. To separate core and F & W losses, test is repeated at variable voltages. It is useful to plot no-load input kW versus Voltage; the intercept is Friction & Windage kW loss component.

F&W and core losses = No load power (Watts) – (No load current)<sup>2</sup> × Stator resistance

**Stator and Rotor I<sup>2</sup>R Losses:**

The stator winding resistance is directly measured by a bridge or volt amp method. The resistance must be corrected to the operating temperature. For modern motors, the operating temperature is likely to be in the range of 100°C to 120°C and necessary correction should be made. Correction to 75°C may be inaccurate. The correction factor is given as follows:

$$\frac{R_2}{R_1} = \frac{235 + t_2}{235 + t_1}, \text{ where, } t_1 = \text{ambient temperature, } ^\circ\text{C} \text{ \& } t_2 = \text{operating temperature, } ^\circ\text{C.}$$

The rotor resistance can be determined from locked rotor test, but rotor I<sup>2</sup>R losses are measured from measurement of rotor slip.

$$\text{Rotor I}^2\text{R losses} = \text{Slip} \times (\text{Stator Input} - \text{Stator I}^2\text{R Losses} - \text{Core Loss})$$

Accurate measurement of slip is possible by stroboscope or non-contact type tachometer. Slip also must be corrected to operating temperature.

**Stray Load Losses:**

These losses are difficult to measure with any accuracy. IEEE Standard 112 gives a complicated method, which is rarely used on shop floor. IS and IEC standards take a fixed value as 0.5 % of input. The actual value of stray losses is likely to be more. IEEE – 112 specifies values from 0.9 % to 1.8 % (see Table 2.1.)

## Motor Selection

The primary technical consideration defining the motor choice for any particular application is the torque required by the load, especially the relationship between the maximum torque generated by the motor (break-down torque) and the torque requirements for start-up (locked rotor torque) and during acceleration periods.

- The duty/load cycle determines the thermal loading on the motor. One consideration with totally enclosed fan cooled (TEFC) motors is that the cooling may be insufficient when the motor is operated at speeds below its rated value.
- Ambient operating conditions affect motor choice, special motor designs are available for corrosive or dusty atmospheres, high temperatures, restricted physical space, etc.
- An estimate of the switching frequency (usually dictated by the process), whether automatic or manually controlled, can help in selecting the appropriate motor for the duty cycle.
- The demand a motor will place on the balance of the plant electrical system is another consideration - if the load variations are large, for example as a result of frequent starts and stops of large components like compressors, the resulting large voltage drops could be detrimental to other equipment.



## ENERGY CONSERVATION AND MANAGEMENT

- Reliability is of prime importance - in many cases, however, designers and process engineers seeking reliability will grossly oversize equipment, leading to sub-optimal energy performance. Good knowledge of process parameters and a better understanding of the plant power system can aid in reducing over sizing with no loss of reliability.
- Inventory is another consideration - Many large industries use standard equipment, which can be easily serviced or replaced, thereby reducing the stock of spare parts that must be maintained and minimizing shut-down time. This practice affects the choice of motors that might provide better energy performance in specific applications. Shorter lead times for securing individual motors from suppliers would help reduce the need for this practice.
- Price is another issue - Many users are first-cost sensitive, leading to the purchase of less expensive motors that may be more, costly on a lifecycle basis because of lower efficiency. For example, energy efficient motors or other specially designed motors typically save within a few years an amount of money equal to several times the incremental cost for an energy efficient motor, over a standard- efficiency motor. **Few of salient selection issues are given below:**
- In the selection process, the power **drawn at 75% of loading** can be a meaningful indicator of energy efficiency.
- Reactive power drawn (kVAr) by the motor.
- Indian Standard 325 for standard motors allows 15% tolerance on efficiency for motors up to 50 kW rating and 10% for motors over 50 kW rating.
- The Indian Standard IS 8789 addresses technical performance of Standard Motors while IS 12615 addresses the efficiency criteria of High Efficiency Motors. Both follow IEC 34-2 test methodology where in, stray losses are assumed as 0.5% of input power. By the IEC test method, the losses are understated and if one goes by IEEE test methodology, the motor efficiency values would be further lowered.
- It would be prudent for buyers to procure motors based on test certificates rather than labeled values.
- The energy savings by motor replacement can be worked out by the simple relation. kW savings = kW output  $\times [1/\eta_{1/n} - 1/\eta_{2/n}]$  where  $\eta_1$  and  $\eta_2$  are the existing and proposed motor efficiency values.
- The cost benefits can be worked out on the basis of premium required for high efficiency vs. worth of annual savings.

### Energy Efficient Motors

Energy-efficient motors (EEM), are the ones in which, design improvements are incorporated specifically to increase operating efficiency over motors of standard design (see figure). Design improvements focus on reducing intrinsic motor losses. Improvements include the use of lower-loss silicon steel, a longer core (to increase active material), thicker wires (to reduce resistance), thinner laminations, smaller air gap between stator and rotor, copper instead of aluminium bars in the rotor, superior bearings and a smaller fan, etc.

Energy-efficient motors now available in India operate with efficiencies that are typically 3 to 4 percentage points higher than standard motors. In keeping with the stipulations of the BIS, energy-efficient motors are designed to operate without loss in efficiency at loads between 75 % and 100 % of rated capacity. This may result in major benefits in varying load applications. The power factor is about the same or may be higher than for standard motors. Furthermore, energy-efficient motors have lower operating temperatures and noise levels, greater ability to accelerate higher-inertia loads, and are less affected by supply voltage fluctuations.



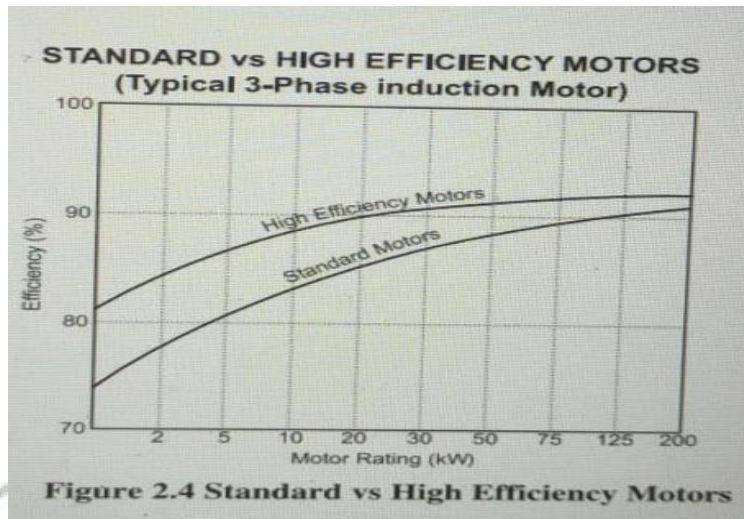

### Minimising Watts Loss in Motors

Improvements in motor efficiency can be achieved without compromising motor performance - at higher cost - within the limits of existing design and manufacturing technology. From the Table it can be seen that any improvement in motor efficiency must result from reducing the Watts losses. In terms of the existing state of electric motor technology, a reduction in watts losses can be achieved in various ways.

**Table Energy Efficient Motors**

Power Loss Area	Efficiency Improvement
1. Iron	Use thinner gauge, lower loss core steel reduces eddy current losses. Longer core adds more steel to the design, which reduces losses due to lower operating flux densities.
2. Stator $I^2R$	Use of more copper and larger conductors increases cross sectional area of stator windings. This lowers resistance (R) of the windings and reduces losses due to current flow (I).
3. Rotor $I^2R$	Use of larger rotor conductor bars increases size of cross section, lowering conductor resistance (R) and losses due to current flow (I).
4. Friction & Windage	Use of low loss fan design reduces losses due to air movement.
5. Stray Load Loss	Use of optimized design and strict quality control procedures minimizes stray load losses.

### Losses in Induction Motors

#### 1. Stator and Rotor $I^2R$ Losses

These losses are major losses and typically account for 55% to 60% of the total losses.  $I^2R$  losses are heating losses resulting from current passing through stator and rotor conductors.  $I^2R$  losses are the function of a conductor resistance, the square of current. Resistance of conductor is a function of conductor material, length and cross-sectional area. The suitable selection of copper conductor size will reduce the resistance. Reducing the motor current is most readily accomplished by decreasing the magnetizing component of current. This involves lowering the operating flux density and possible shortening of air gap. Rotor  $I^2R$  losses are a function of the rotor conductors (usually aluminium) and the rotor slip. Utilisation of copper conductors will reduce the winding resistance. Motor operation closer to synchronous speed will also reduce rotor  $I^2R$  losses.

**2. Core Losses**

Core losses are those found in the stator-rotor magnetic steel and are due to hysteresis effect and eddy current effect during 50 Hz magnetization of the core material. These losses are independent of load and account for 20 – 25 % of the total losses.

The hysteresis losses which are a function of flux density, are be reduced by utilizing low loss grade of silicon steel laminations. The reduction of flux density is achieved by suitable increase in the core length of stator and rotor. Eddy current losses are generated by circulating current within the core steel laminations. These are reduced by using thinner laminations.

**3. Friction and Windage Losses**

Friction and windage losses result from bearing friction, windage and circulating air through the motor and account for 8 – 12 % of total losses. These losses are independent of load. The reduction in heat generated by stator and rotor losses permit the use of smaller fan. The windage losses also reduce with the diameter of fan leading to reduction in windage losses.

**4. Stray Load-Losses**

These losses vary according to square of the load current and are caused by leakage flux induced by load currents in the laminations and account for 4 to 5 % of total losses. These losses are reduced by careful selection of slot numbers, tooth/slot geometry and air gap.

**Factors Affecting Energy Efficiency & Minimizing Motor Losses in Operation**

Motor performance is affected considerably by the quality of input power, that is the actual volts and frequency available at motor terminals vis-à-vis rated values as well as voltage and frequency variations and voltage unbalance across the three phases. Motors in India must comply with standards set by the Bureau of Indian Standards (BIS) for tolerance to variations in input power quality. The BIS standards specify that a motor should be capable of delivering its rated output with a voltage variation of +/- 6 % and frequency variation of +/- 3 %. Fluctuations much larger than these are quite common in utility-supplied electricity in India. Voltage fluctuations can have detrimental impacts on motor performance. Voltage unbalance, the condition where the voltages in the three phases are not equal, can be still more detrimental to motor performance and motor life. Unbalance typically occurs as a result of supplying single-phase loads disproportionately from one of the phases. It can also result from the use of different sizes of cables in the distribution system.

Example 1:

A three phase, 10 kW motor has the name plate details as 415 V, 18.2 amps and 0.9 PF. Actual input measurement shows 415 V, 12 amps and 0.7 PF which was measured with power analyzer during motor running. Determine the motor loading?

Rated output at full load = 10 kW

$$\text{Rated input at full load} = \sqrt{3} \times V \times I \times \text{Cos}\Phi = 1.732 \times 0.415 \times 18.2 \times 0.9 = 11.8 \text{ kW}$$

The rated efficiency of motor at full load =  $(10 \times 100) / 11.8 = 85\%$

Measured (Actual) input power =  $1.732 \times 0.415 \times 12 \times 0.7 = 6.0 \text{ kW}$

$$\text{Motor loading \%} = \frac{\text{Measured kW}}{\text{Rated kW}} \times 100 = \frac{6.0}{11.8} \times 100 = 51.2\%$$

Example 2:

A 400-Watt mercury vapor lamp was switched on for 10 hours per day. The supply volt is 230

V. Find the power consumption per day? (Volt = 230 V, Current = 2 amps, PF = 0.8)

## ENERGY CONSERVATION AND MANAGEMENT

Electricity consumption (kWh) =  $V \times I \times \cos\Phi \times \text{No of Hours}$

$$= 0.230 \times 2 \times 0.8 \times 10 = 3.7 \text{ kWh or Units}$$

Example 3:

An electric heater of 230 V, 5 kW rating is used for hot water generation in an industry. Find electricity consumption per hour (a) at the rated voltage (b) at 200 V.

(a) Electricity consumption (kWh) at rated voltage =  $5 \text{ kW} \times 1 \text{ hour} = 5 \text{ kWh}$ .

(b) Electricity consumption at 200 V (kWh) =  $(200 / 230)^2 \times 5 \text{ kW} \times 1 \text{ hour} = 3.78 \text{ kWh}$ .

Example 4

The utility bill shows an average power factor of 0.72 with an average KW of 627. How much kVAR is required to improve the power factor to .95?

Using formula

$$\cos \Phi 1 = 0.72, \tan \Phi 1 = 0.963$$

$$\cos \Phi 2 = 0.95, \tan \Phi 2 = 0.329$$

$$\text{kVAR required} = P (\tan \Phi 1 - \tan \Phi 2)$$

$$= 627 (0.964 - 0.329)$$

$$= 398 \text{ kVAR}$$

### Motor Efficiency Computation

Example:2

Motor Specifications

Rated power = 34 kW/45 HP Voltage = 415 Volt

Current = 57 Amps Speed = 1475 rpm Insulation class = F Frame = LD 200 L Connection = Delta

No load test Data

Voltage, V = 415 Volts Current, I = 16.1 Amps Frequency, F = 50 Hz

Stator phase resistance at 30°C = 0.264 Ohms No load power, P<sub>nl</sub> = 1063.74 Watts

- Calculate iron plus friction and windage losses
- Calculate stator resistance at 120°C
$$R_2 = R_1 \times \frac{235 + t_2}{235 + t_1}$$
- Calculate stator copper losses at operating temperature of resistance at 120°C
- Calculate full load slip(s) and rotor input assuming rotor losses are slip times rotor input.
- Determine the motor input assuming that stray losses are 0.5 % of the motor rated power
- Calculate motor full load efficiency and full load power factor

**Solution**

- Let Iron plus friction and windage loss, P<sub>i</sub> + f<sub>w</sub>  
No load power, P<sub>nl</sub> = 1063.74 Watts



## ENERGY CONSERVATION AND MANAGEMENT

Stator Copper loss,  $P_{st-30^{\circ}\text{C}}$  (Pst.cu)

$$= 3 \times (16.1 / \sqrt{3})^2 \times 0.264$$

$$= 68.43 \text{ Watts}$$

$$P_i + f_w = P_{nl} - P_{st.cu}$$

$$= 1063.74 - 68.43$$

$$= 995.3 \text{ W}$$

b) Stator Resistance at  $120^{\circ}\text{C}$ ,

$$R_{120^{\circ}\text{C}} = 0.264 \times \frac{120 + 235}{30 + 235}$$

$$= 0.354 \text{ ohms per phase}$$

c) Stator copper losses at full load,  $P_{st.cu}$   $120^{\circ}\text{C}$

$$= 3 \times (57 / \sqrt{3})^2 \times 0.354$$

$$= 1150.1 \text{ Watts}$$

d) Full load slip

$$S = (1500 - 1475) / 1500$$

$$= 0.0167$$

$$\begin{aligned} \text{Rotor input, } P_r &= P_{\text{output}} / (1-S) \\ &= 34000 / (1-0.0167) \\ &= 34577.4 \text{ Watts} \end{aligned}$$

e) Motor full load input power,  $P_{\text{input}}$

$$\begin{aligned} &= P_r + P_{st.cu} \text{ } 120^{\circ}\text{C} + (P_i + f_w) + P_{\text{stray}} \\ &= 34577.4 + 1150.1 + 995.3 + (0.005^* \times 34000) \\ &= 36892.8 \text{ Watts} \end{aligned}$$

\*where, stray losses = 0.5% of rated output (assumed)

f) Motor efficiency at full load

$$\begin{aligned} \text{Efficiency} &= \frac{P_{\text{output}}}{P_{\text{input}}} \times 100 \\ &= \frac{34000}{36892.8} \times 100 \\ &= 92.2 \% \end{aligned}$$

## Variable speed drives (VSDs)

- A VSD controls the speed and torque of an AC motor by converting fixed frequency and voltage input to a variable frequency and voltage output.
- VSD motor control is one of the main areas where energy savings can be achieved. Savings will depend on the nature and variability of the load and total operating hours. Where process output requirements vary by 30% or more, matching the load with a VSD can reduce energy use significantly.
- Motor systems fitted with VSDs can bring **the following benefits**:
- reduction in maximum power demand and associated charges
  - a) Reduced stress on system components
  - b) Accurate system control of parameters such as pressure, flow and temperature
  - c) Improved workplace safety and amenity, through reduced heat and noise levels

## ENERGY CONSERVATION AND MANAGEMENT

- d) Ability to interface VSDs to wider process control systems such as building management systems (BMS)
- e) Precise flow control without the energy losses of throttling and ensures the system isn't running at full speed when not necessary.
- Depending on the application, mechanical and hydraulic VSDs can suffer from inherent losses and are therefore not as energy-efficient as electronic controls.

### Application of Variable Speed Drives (VSD)

Although there are many methods of varying the speeds of the driven equipment such as hydraulic coupling, gear box, variable pulley etc., the most possible method is one of varying the motor speed itself by varying the frequency and voltage by a variable frequency drive.

#### Variable frequency drives

- Modern electronic VSDs are also known as variable frequency drives (VFDs) as they work by varying the AC electrical input frequency to control drive speed technology has widespread uptake and application with AC induction motors.
- VFDs are increasingly favoured by industry due to their versatility and control where speeds can be accurately varied from zero rpm to over 100% of the rated speed.
- VFDs also enable motor control in either direction.
- VFDs may be of little benefit where precise motor speed control does not assist the production process or where hours of reduced demand are few.
- VFDs are also not recommended for applications in which slowing down the machine causes operating problems, such as insufficient torque or poor cooling

#### Concept of Variable Frequency Drive

The speed of an induction motor is proportional to the frequency of the AC voltage applied to it, as well as the number of poles in the motor stator. This is expressed by the equation:

$$\text{RPM} = (f \times 120) / p$$

Where  $f$  is the frequency in Hz, and  $p$  is the number of poles in any multiple of 2.

Therefore, if the frequency applied to the motor is changed, the motor speed changes in direct proportion to the frequency change. The control of frequency applied to the motor is the job given to the VSD.

The VSD's basic principle of operation is to convert the electrical system frequency and voltage to the frequency and voltage required to drive a motor at a speed other than its rated speed. The two most basic functions of a VSD are to provide power conversion from one frequency to another, and to enable control of the output frequency.

#### VSD Power Conversion

As illustrated by Figure, there are two basic components, a rectifier and an inverter, to accomplish power conversion.

The rectifier receives the 50-Hz AC voltage and converts it to direct current (DC) voltage. A DC bus inside the VSD functions as a "parking lot" for the DC voltage. The DC bus energizes the inverter, which converts it back to AC voltage again. The inverter can be controlled to produce an output frequency of the proper value for the desired motor shaft speed.

#### Factors for Successful Implementation of Variable Speed Drives

##### a) Load Type for Variable Frequency Drives

The main consideration is whether the variable frequency drive application requires a **variable torque or constant torque** drive. If the equipment being driven is centrifugal, such as a fan or

## ENERGY CONSERVATION AND MANAGEMENT

pump, then a variable torque drive will be more appropriate. Energy savings are usually the primary motivation for installing variable torque drives for centrifugal applications. For example, a fan needs less torque when running at 50% speed than it does when running at full speed. Variable torque operation allows the motor to apply only the torque needed, which results in reduced energy consumption.

Conveyors, positive displacement pumps, punch presses, extruders, and other similar type applications require constant level of torque at all speeds. In which case, constant torque variable frequency drives would be more appropriate for the job. A constant torque drive should have an overload **current capacity of 150%** or more for one minute. Variable torque variable frequency drives need only an overload current capacity of 120% for one minute since centrifugal applications rarely exceed the rated current.

**If tight process control is needed**, then you may need to utilize a sensor less vector, or flux vector variable frequency drive, which allow a high level of accuracy in controlling speed, torque, and positioning.

### b) Motor Information

The following motor information will be needed to select the proper variable frequency drive:

**Full Load Amperage Rating.** Using a motor's horsepower is an inaccurate way to size variable frequency drives.

**Speed Range.** Generally, a motor should not be run at any speed less than 20% of its specified maximum speed allowed. If it is run at a speed less than this without auxiliary motor cooling, the motor will overheat. Auxiliary motor cooling should be used if the motor must be operated at very slow speeds.

**Multiple Motors.** To size a variable frequency drive that will control more than one motor, add together the full-load amp ratings of each of the motors. All motors controlled by a single drive must have an equal voltage rating.

### c) Efficiency and Power Factor

The variable frequency drive should have an efficiency rating of 95% or better at full load.

Variable frequency drives should also offer a true system power factor of 0.95 or better across the operational speed range, to save on demand charges, and to protect the equipment (especially motors).

### d) Protection and Power Quality

Motor overload Protection for instantaneous trip and motor over current.

**Additional Protection:** Over and under voltage, over temperature, ground fault, control or microprocessor fault. These protective circuits should provide an orderly shutdown of the VFD, provide indication of the fault condition, and require a manual reset (except under voltage) before restart. Under voltage from a power loss shall be set to automatically restart after return to normal. The history of the previous three faults shall remain in memory for future review.

**If a built-up system is required**, there should also be externally-operated short circuit protection, door-interlocked fused disconnect and circuit breaker or motor circuit protector (MCP)

## Information needed to Evaluate Energy Savings for Variable Speed Application

### 1. Method of flow control to which adjustable speed is compared:

- output throttling (pump) or dampers (fan)
- recirculation (pump) or unrestrained flow (fan)



## ENERGY CONSERVATION AND MANAGEMENT

- adjustable-speed coupling (eddy current coupling)
- inlet guide vanes or inlet dampers (fan only)
- two-speed motor.

### 2. Pump or fan data:

- head v's flow curve for every different type of liquid (pump) or gas (fan) that is handled
- Pump efficiency curves.

### 3. Process information:

- specific gravity (for pumps) or specific density of products (for fans)
- system resistance head/flow curve
- equipment duty cycle, i.e. flow levels and time duration.

### 4. Efficiency information on all relevant electrical system apparatus:

- motors, constant and variable speed
- variable speed drives
- gears
- transformers.

### Lighting

Lighting is provided in industries, commercial buildings, indoor and outdoor for providing comfortable working environment.

Lighting is an area, which provides a major scope to achieve energy efficiency at the design stage, by incorporation of modern energy efficient lamps, luminaires and gears, apart from good operational practices.

### Quality of light

Any study of lighting design must include a thorough understanding of both the PHYSICAL and the PSYCHOLOGICAL properties of light.

Knowledge of the behavior and properties of light can help explain vision and human perception. The lighting designer is especially interested in how the properties of light affect the eye/brain process and cause feelings and emotions. An understanding of the physical properties of light can also help explain optics, lenses, color theory, lighting and projection.

### Lumen

It is a unit of light flow or luminous flux. The lumen rating of a lamp is a measure of the total light output of the lamp. The most common measurement of light output (or luminous flux) is the lumen. Light sources are labeled with an output rating in lumens.

### Lux

It is the metric unit of measure for illuminance of a surface. One lux is equal to one lumen per square meter.

### Lamp Circuit Efficacy

It is the amount of light (lumens) emitted by a lamp for each watt of power consumed by the lamp circuit, i.e. including control gear losses. This is a more meaningful measure for those lamps that require control gear. Unit: lumens per circuit watt (lm/W).

### Light sources

- Our vision and thus our contact with the environment is inextricably connected to the light.

## ENERGY CONSERVATION AND MANAGEMENT

- The sun as a source of light that accompanies us since our inception has one big drawback: it is not present at night.
- In order to extend the day and thus have more opportunities for work, entertainment, development humans very early start to artificial light sources.
- Today's lighting with artificial light sources is an indispensable part of our lives

### Types of light sources

**Light sources can be divided according to different criteria:**

**1.Primary light sources:** emit light by themselves and convert other forms of energy into light

**2.Secondary light sources:** do not emit light by themselves, but refract, reflect or otherwise alter the light from primary light sources.

The sun is so the primary light source but the moon is secondary.

Or

**Light sources can be divided according to different criteria:**

**1.Natural light sources:** that are all the time or occasionally present in nature without human intervention.

- a) **The sun** is the main primary and natural source of light.
- b) **The moon** is also natural light source. However, the moon is secondary light source, because it only reflects light of the sun.
- c) **Sky and clouds are also natural light source:** The atmosphere around the earth as well as clouds partly refract and partly reflect sun light. The light is also partly dispersed.
- d) **Windows and skylights** are natural light sources in the indoor environment. They refract natural light of the sun (and partially disperse it) in the indoor **Daylight - properties**
  - Daily routine: low light level in the morning, level then increases until noon and then decreases again in the evening.
  - Light is coming from above and from the side.
  - The position of the light source changes with time as the sun "travels" from east to west.
  - Very rapid changes in brightness due to the weather (clouds).
  - Daylight has its advantages (high levels, high illuminances of indoor environment, daily rhythm favourable technical parameters, energy savings) as well as weaknesses (rapid changes, strong shadows, limited duration, the need for heating and air-conditioning, glare ) but the daylight is precisely what we are accustomed to during evolution so it is desirable that the artificial light mimics daylight environment.

**2.Artificial light sources:** that were introduced by humans because of certain advantages.

The most famous natural source is the sun, the most famous artificial source.

The history of artificial light sources is almost as long as the

- history of mankind:
- Fire: 400,000 BC
- Oil lamps: 13,000 BC
- Candles: 400
- Gas lamps: 1792
- Electric arc lamps: 1809
- Petroleum lamps: 1853

## ENERGY CONSERVATION AND MANAGEMENT

- Incandescent lamps: 1879
  - a) **Candle (400 AD)** First candles were probably made by the ancient Egyptians, and were also widely used by the Romans. They were made from hardened tallow. Gas discharge lamps: 1901
  - b) **Oil lamp with cylindrical wick (1784 AD)** One of the major improvements in oil lamps was use of circular hollow wick and glass cylinder (F.P.A. Argand, Swiss). They used mainly whale oil. The amount of light is about the same as with 10 candles.
  - c) **Betty oil lamp (1790 AD)** Slightly improved oil lamp was primarily used in America during its colonization. Amount of light was like with 2 candles and they used animal or vegetable fats
  - d) **Gas lamp (1814 AD)** 1807 gas lamps were introduced for lighting the streets of London. The merit goes to the Scottish engineer Murdock, who lit his home and workshop with gas since 1792. Gas mantle was patented in 1885 (Thorium and cerium oxide).
  - e) **Limelight (1816 AD)** Magnesium lamp or lime lamp emits light without direct application of flame. Light is produced by the oxidation of lime or later magnesium (Limelight). To oxidized lime, it is necessary to heat it with oxygen and hydrogen flame. The light is about 83 times stronger than with Argand lamp (about 800 candles).
  - f) **Matches (1827 AD)** Also English invention by chemist and pharmacist John Walker. The matches significantly facilitated lighting of lamps. Walker had never patented his invention.
  - g) **Kerosene lamp (1853 AD)** Improved Argand lamp fuelled by kerosene. It was improved further with duplex burner (two parallel flat wick). They appear in Germany in 1853 for the first time.
  - h) **Swan lamp**
  - i) **Electric arc lamp**
  - j) **Edison lamp**
  - k) **(1879)** His first successful light bulb used carbonized cotton thread in vacuum and burns for 45 hours. Later he used carbonized bamboo fibers. In 1880, Edison receives a patent for carbon filament light bulb but was declared invalid in 1883. He got it back in 1889.
  - l) **High pressure mercury lamp.**
  - m) **Low pressure sodium lamp**

### Energy Efficiency/Saving projects

- Does street light require such complex architecture? What will be the implementation cost?
- Energy Saving Company (ESCO) – BEE listed
- Investment is done by ESCO and financial risk to the municipal corporation or government is low
- Return on Investment is obtained to ESCO based on savings
- Sharing of profits on public private partnership (PPP) mode
- CDM benefits
- Dimmable ballast or Magic Box
- Voltage regulator
- Centralized control using GSM/SCADA
- Regular maintenance of fixtures
- Power factor improvement techniques

### Energy Efficiency Techniques

- Use of Day, light, turn off the lights when not required
- Proper maintenance of lamps



## ENERGY CONSERVATION AND MANAGEMENT

- Replacement with energy efficient lamps
- Incorporate proper lighting controls
- Use of electronic chokes instead of conventional electromagnetic ballasts
- Use of dimming controls
- Use of 28-watt T5 instead of 40-watt standard FTL

### Lighting Controls

- Types
  - a) Infrared sensors
  - b) Motion sensors
  - c) Automatic timers
  - d) Dimmers
- SCADA, GSM/GPRS based centralized control system for street light
- Save energy by on/off and dimming
- Up to 40% energy saving in street lights without replacing existing fixtures

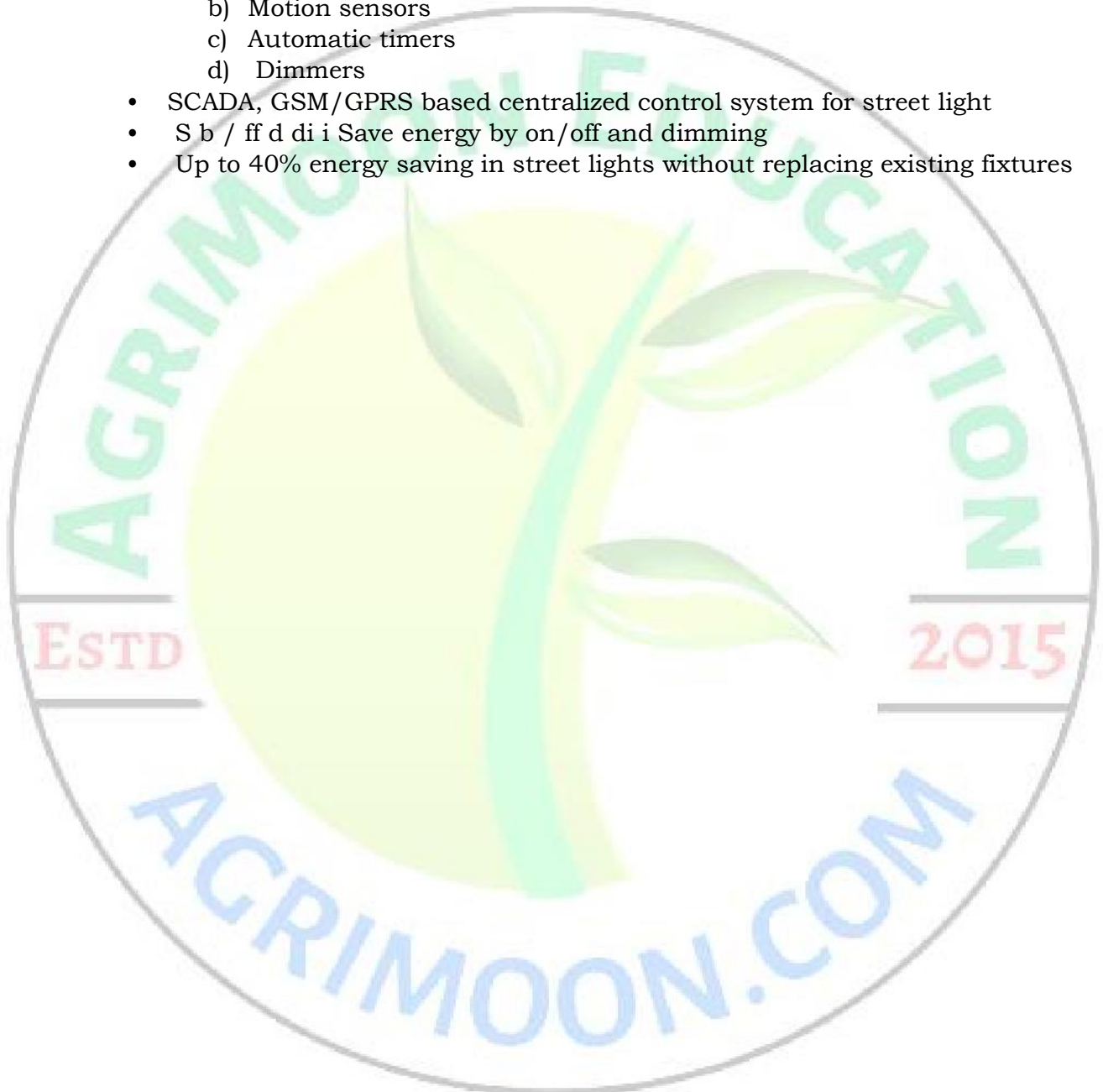

**Lesson 7****Energy performance assessment of boilers****Introduction**

Performance of the boiler, like efficiency and evaporation ratio reduces with time, due to poor combustion, heat transfer fouling and poor operation and maintenance. Deterioration of fuel quality and water quality also leads to poor performance of boiler. Efficiency testing helps us to find out how far the boiler efficiency drifts away from the best efficiency. Any observed abnormal deviations could therefore be investigated to pinpoint the problem area for necessary corrective action. Hence it is necessary to find out the current level of efficiency for performance evaluation, which is a prerequisite for energy conservation action in industry.

**Stoichiometry**

Stoichiometry is the study of the relationship between relative amounts of substances. The formula of a compound provides information about the relative amount of each element

present in either one molecule of the compound or one mole of the compound. For example, one molecule of  $\text{CaCl}_2$  contains 1 mol  $\text{Ca}^{2+}$  ions and 2 mol  $\text{Cl}^-$  ions.

Stoichiometry can be used to determine the chemical formula of a compound by studying the relative amounts of elements present or can be used to study the relative amounts of compounds that are consumed and produced during a chemical reaction

**HIGH EFFICIENCY BOILER**

- A boiler works by heating water, which is conducted through radiators, radiant floor systems or a coil.
- With a standard, conventional boiler, some of the energy that is used to heat the boiler, whether it is a fossil fuel or natural gas, gets lost in the combustion process.
- When fuel is burned in a boiler, it produces flue gas, similar to the exhaust from your car. This gas leaves the combustion chamber and enters the flue passages.
- The combustion chamber and flue passages (called the heat exchanger) are surrounded by water.
- By design, these flue passages harvest heat from the flue gas and transfer it to the water inside the heat exchanger.
- The more energy that the heat exchanger can harvest from the flue gas, the savings on fuel.
- A high efficiency boiler is designed to trap the escaping heat and direct it back into heating the home through a process known as “condensing.”
- High efficiency condensing boilers produce heat by burning natural gas or propane fuel.
- The word “condensing” refers to the fact that these appliances are able to extract heat from the combustion process so efficiently that the flue gases leave the boiler at a much lower temperature than in a standard boiler.
- The temperature of these flue gases is low enough that they actually condense inside the heat exchanger.

**Advantages of high efficiency boilers**

- Depending upon its age and type, a standard boiler will typically, be 80 to 85% efficient.
- In comparison, a condensing boiler may provide up to 96% efficiency, which means that only 4 cents of heat escapes.
- High efficiency condensing boilers are also good for the environment.
- High efficiency boilers use less energy.
- Installation flexibility.
- Reduced installation cost

## ENERGY CONSERVATION AND MANAGEMENT

- Smaller size and lighter.
- Operate most efficiency with low system temperature.
- Fuel cost savings.

### Types of Boilers

#### 1) Gas-Fired Boilers

- Gas-fired boilers are one of the most highly-efficient and durable types of boilers.
- They may be powered by either natural gas or propane.
- It generally uses less fuel, because it can recapture the energy that is produced by gases leaving the boiler.
- These types of boilers rarely break down and do not need a lot of maintenance.

#### 2) Oil-Fired Boilers

- Oil-fired boilers are typically found in areas that have little or no access to natural gas.
- An oil boiler does not require access to a gas supply.
- It is energy efficient.
- Although operating costs are affected by fluctuations in the price of oil, some manufacturers are now selling models that use biodiesel fuel.

#### 3) Electric Boilers

- Electric boiler is a large tank that has an inlet and an outlet.
- Electricity warms up the water to very high temperatures fastly.

#### Advantages includes:

- Energy efficient
- Quiet
- Clean
- More compact
- Easy to install

However, these boilers can be very costly, because the electricity

#### Ways to increase boiler efficiency

##### 1. Increase boiler efficiency: lower the stack temperature

- Lowering stack temperatures may be as simple as a day/night set back.
- This lowers the operating pressure for steam boilers and the operating temperature for hydronic boilers when idling at night or mild days.

##### 2. Install an economizer

- An economizer uses the wasted hot flue gas to heat feed water on its way to the boiler.
- Economizers save fuel and prevent damaging effects of feeding the boiler with cold water.

##### 3. Tune the burner regularly

- For proper combustion of fuel inside the boiler, a certain amount of oxygen is required.
- If too little air is present, the carbon in the fuel will be oxidized, making carbon monoxide.
- This causes less heat to release because the fuel isn't completely burned, which lowers fuel use efficiency.
- Low air generates soot, smoke and carbon monoxide, all of which are very dangerous.
- Too much air also reduces efficiency.



## ENERGY CONSERVATION AND MANAGEMENT

- The extra air comes in cold and sent out the stack hot, wasting heat.

An optimal process provides just enough air for the fuel to burn safely.

- To achieve this, we measure the amount of air needed with an O<sub>2</sub> probe. We insert the probe into the stack while we tune the burner for optimum boiler efficiency. However, in some facilities, the temperature of the air drawn into the burner varies with the seasons.

- This requires the tuning of the burner more frequently for maximum savings.

### **4. Install a variable frequency drive**

### **5. Increase boiler efficiency: insulate your valves**

- Many plants remove the insulation on valves in the boiler room for maintenance and never put it back because it is a hassle.
- However, exposing these large valves to the air causes a lot of heat loss and can make the boiler room unbearably hot.

### **6. Clean the fireside**

- Over time, soot may build up on the fireside of the boiler tubes, especially with older equipment.
- This layer of soot acts as an insulator, bringing down the heat transfer rate and increasing fuel use.
- Because of the lower heat transfer rate, the hot gases pass through without transferring the heat to the water, increasing your stack temperature.
- Cleaning and inspecting boiler tubes as part of regular boiler maintenance ensures that the soot remains minimal.
- This does improve the overall boiler efficiency.

### **7. Preheat combustion air**

- The burner has to heat incoming combustion air with the flame. If the air introduced to the burner is warmer, it requires less fuel to make the same amount of steam in the boiler.
- A modest 40 °F increase in fresh air temperature can save 1% of the fuel bill.

### **8. Clean the water side**

- Keeping the waterside of boiler clean and free of leaks requires diligent water treatment.
- Inspect boiler 's waterside regularly.
- Clean out any mud legs or mud drums to ensure good heat transfer from the metal to the water.
- Scale will accumulate on heat transfer surfaces because of high water hardness, improper chemicals, and not blowing down the boiler regularly.
- This scale will impede the heat transfer, reducing your boiler efficiency.
- The scale will also keep the water from cooling these heat transfer surfaces.

## ENERGY CONSERVATION AND MANAGEMENT

- If left untreated, the scale can cause the boiler to overheat, leading to costly boiler repairs and leaks.

### 9. Return condensate to the boiler

- Condensate forms as the steam transfers its heat and condenses.
- The clean water is without dissolved solids or gasses that are ready for use again in your boiler.
- The water is already hot and therefore requires significantly less fuel to make it into steam again.
- Rerouting condensate back into the feed water system can reduce wastewater treatment and sewer costs.

### 10. Recover heat from boiler blowdown

- Recovering the heat from the boiler blowdown can increase boiler efficiency.
- The blowdown valve is used to remove boiler water which contains soluble and insoluble solids.
- It helps reduce the level of dissolved solids in the boiler water to prevent the boiler scale.
- Unfortunately, when it removes hot water, it also wastes energy.
- Installing a blowdown heat exchanger, flash tank or combination of the two can help recover some of this energy for boiler system.
- Using heat recovery to cool down the blowdown and heat up your make-up water will improve energy efficiency.

### 11. Control blowdown rate

- Blowdown removes impurities, like water hardness, from the boiler and is required to keep the boiler surfaces clean.
- However, blowdown also removes heat from the system.
- Water enters the system cold, is heated up to the boiler temperature, and leaves through the blowdown.
- To control the heat sent down the drain, blowdown should be limited only to the amount necessary to control the dissolved solids.
- For serious savings, control dissolved solids with an automatic blowdown valve.
- If you blow down the boiler when it regularly, you can save a lot of energy.
- This also reduces risking damage to your boiler from the scale.

### 12. Reduce excess air

- Boilers require excess air in order to complete combustion.
- Although necessary, the amount of excess air can result in totally different efficiencies for your boiler.
- Too little excess air and the boiler will build up soot and dangerous carbon monoxide, while too much excess air reduces efficiency.
- Fortunately, there are automatic combustion control systems that can intelligently monitor required air quantities for your combustion systems.

## ENERGY CONSERVATION AND MANAGEMENT

- Tuning can keep your burner running at its best, but it is limited to the best your old burner can offer.

### 13. Reduce carry-over

- Carry-over is boiler water that leaves the boiler in the steam but is still water.
- It carries impurities such as dissolved solids with it. These impurities leave deposits around the steam system. They get caught inside intricate devices like control valves and pressure regulators. This causes a lot of damage and increased maintenance.
- Carry-over happens because of a number of things. The solution depends on the cause.

### 14. Survey steam traps

- Stuck, worn out, or just broken steam traps can stick open, allowing valuable steam to blow right through into the condensate system.
- Find any malfunctioning traps and replace them to save time and save money.

### 15. Reduce steam usage

- The best way to save on fuel and electricity to boiler is to reduce steam usage in processes.

#### Purpose of the Performance Test

- To find out the efficiency of the boiler
- To find out the evaporation ratio

The purpose of the performance test is to determine actual performance and efficiency of the boiler and compare it with design values or norms. It is an indicator for tracking day-to-day and season-to-season variations in boiler efficiency and energy efficiency improvements.

#### Performance Terms and Definitions

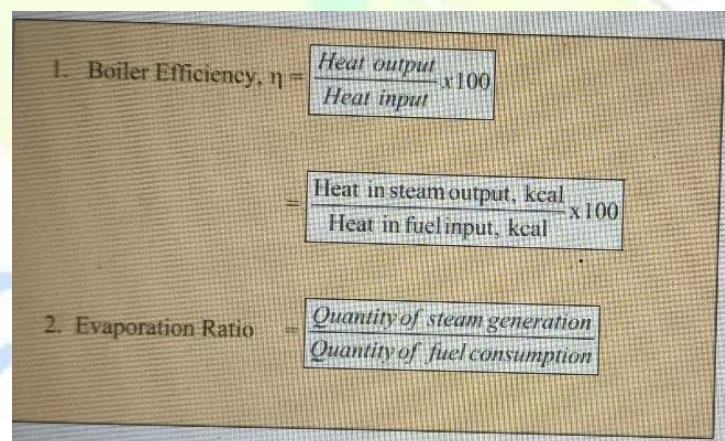

1. Boiler Efficiency,  $\eta = \frac{\text{Heat output}}{\text{Heat input}} \times 100$

$= \frac{\text{Heat in steam output, kcal}}{\text{Heat in fuel input, kcal}} \times 100$

2. Evaporation Ratio =  $\frac{\text{Quantity of steam generation}}{\text{Quantity of fuel consumption}}$

#### Efficiency computation of Boilers

Efficiency testing helps us to find out how far the boiler efficiency drifts away from the best efficiency. Any observed abnormal deviations could therefore be investigated to pinpoint the problem area for necessary corrective action. Hence it is necessary to find out the current level of efficiency for performance evaluation, which is a pre-requisite for energy conservation action in industry.

Most standards for computation of boiler efficiency, including IS 8753 and BS845 are designed for spot measurement of boiler efficiency. Basically, Boiler efficiency can be tested by the following methods:

- 1) **The Direct Method:** Where the energy gain of the working fluid (water and steam) is compared with the energy content of the boiler fuel.



## ENERGY CONSERVATION AND MANAGEMENT

2) **The Indirect Method:** Where the efficiency is the difference between the losses and the energy input.

### .1 The Direct Method Testing

This is also known as 'input-output method' due to the fact that it needs only the useful output (steam) and the heat input (i.e. fuel) for evaluating the efficiency. This efficiency can be evaluated using the formula:

$$\text{Boiler Efficiency} = \frac{\text{Heat Output}}{\text{Heat Input}} \times 100$$

$$\text{Boiler Efficiency} = \frac{\text{Steam flow rate} \times (\text{steam enthalpy} - \text{feed water enthalpy})}{\text{Fuel firing rate} \times \text{Gross calorific value}} \times 100$$

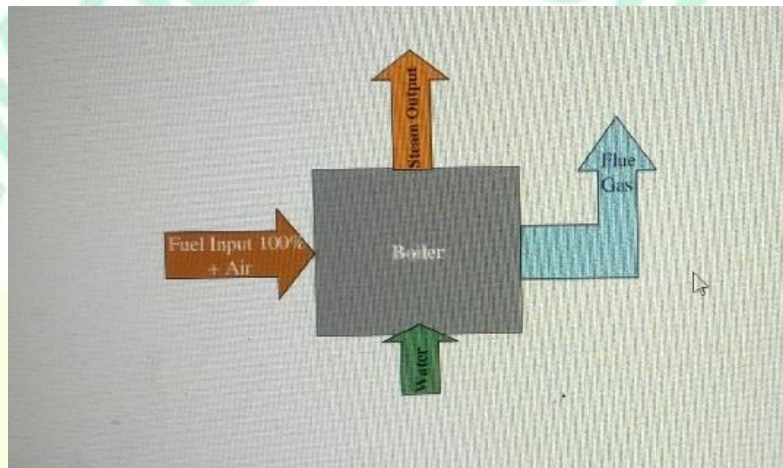

#### Example

Water consumption and coal consumption were measured in a coal-fired boiler at hourly intervals. Weighed quantities of coal were fed to the boiler during the trial period. Simultaneously water level difference was noted to calculate steam generation during the trial period. Blow down was avoided during the test. The measured data is given below.

#### Type of boiler: Coal fired Boiler

##### Heat output data

Quantity of steam generated (output)	: 8 TPH
Steam pressure / temperature	: 10 kg/cm <sup>2</sup> (g)/ 180°C
Enthalpy of steam(dry & Saturated) at 10 kg/cm <sup>2</sup> (g) pressure	: 665 kCal/kg
Feed water temperature	: 85°C
Enthalpy of feed water	: 85 kCal/kg

##### Heat input data

Quantity of coal consumed (Input)	: 1.6 TPH
GCV of coal	: 4000 kCal/kg

**Calculation**

$$\text{Boiler efficiency } (\eta) = \frac{Q \times (H - h) \times 100}{(q \times \text{GCV})}$$

- Where Q = Quantity of steam generated per hour (kg/hr)  
 q = Quantity of fuel used per hour (kg/hr)  
 GCV = Gross calorific value of the fuel (kCal/kg)  
 H = Enthalpy of steam (kCal/kg)  
 h = Enthalpy of feed water (kCal/kg)

$$\begin{aligned} \text{Boiler efficiency } (\eta) &= \frac{8 \text{ TPH} \times 1000\text{kg/T} \times (665 - 85) \times 100}{1.6 \text{ TPH} \times 1000\text{kg/T} \times 4000 \text{ kCal/kg}} \\ &= 72.5\% \end{aligned}$$

**Factors Affecting Boiler Performance**

- The various factors affecting the boiler performance are listed below:
- Periodical cleaning of boilers
- Periodical soot blowing
- Proper water treatment programme and blow down control
- Draft control
- Excess air control
- Percentage loading of boiler
- Steam generation pressure and temperature
- Boiler insulation
- Quality of fuel

**Application of recuperator to recover energy from flue gases from boiler, dg exhaust, hot air from spray dryer and fluidized bed dryer**

**Recuperator**

- A Recuperators is a special purpose counter –flow energy recovery heat exchanger positioned within the supply and exhaust air streams of and air handling system, or in the exhaust gases of an industrial process, in order to recover the waste heat.
- Generally, they are used to extract heat from the exhaust and use it to preheat air entering the combustion system.
- Thus, they improve the energy efficiency of a system as a whole.
- Recuperators can be based on radiation, convection, or combinations
- They are constructed out of either metallic or ceramic materials.

**Metallic radiation Recuperators**

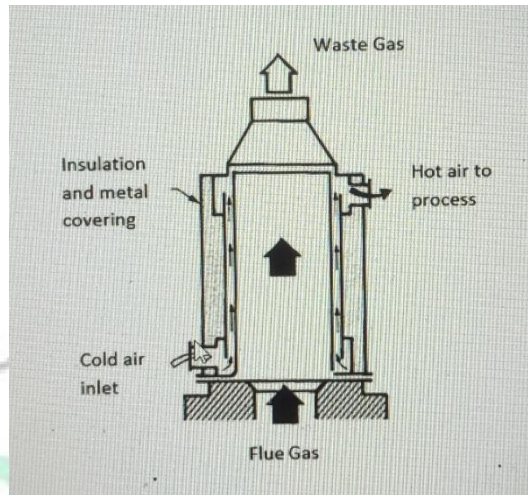

- Simplest recuperator
- Two metal tubes
- Less fuel is burnt per furnace load
- Heat transfer mostly by radiation

**Convective Recuperators**

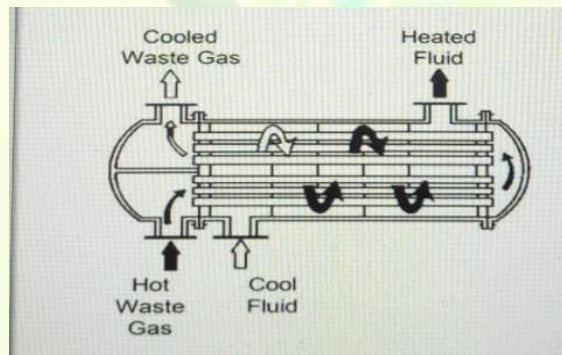

- Hot gas through parallel small diameter tubes
  - Tubes can be baffle to allow gas to pass over them again
  - Baffling increases heat exchange but more expensive exchanger is needed
- Waste heat recovery from exhaust flue gas in hot water boiler**
- It is well known that recovering a portion of the waste heat enhances the efficiency of boilers and provides fuel savings.
  - Boiler efficiency has a great effect on heating-related energy savings.
  - So, maximizing the heat transfer to the water and minimizing the heat losses to around have importance in the boiler systems.
  - Heat can be lost from boilers by several ways; including hot exhaust gases, radiation losses etc.

Recuperators (the most common heat recovery ventilation devices) has attractive advantages such as simple structure, little effects on the thermal system, and reduction of fuel consumption

- They recover exhaust heat waste in medium to high temperature applications such as hot water or steam boilers, annealing or soaking ovens, melting furnaces, gas incinerator, reheat furnaces etc.

**Waste heat recovery from exhaust of a diesel generator set**

- Heat available in the exhaust of a diesel engine can be an important heat source to provide additional power using separate Rankine cycle(RC)
  - The exhaust of a diesel engine contains 40% of input energy and usually this energy is wasted by expelling to the environment



## ENERGY CONSERVATION AND MANAGEMENT

- The overall efficiency of the diesel engine can be improved by recovering this waste heat to produce additional power by turbine using ORC.

### Waste heat recovery

- Objective is to minimize stack gas losses and losses from blowdown water and expelled condensate.
- Reduction in exit flue temperature will help minimize the flue gas losses.
- Stack gas waste recovery can be achieved through three primary means : Economizers, Air preheaters, Turbulators.

### Economizers

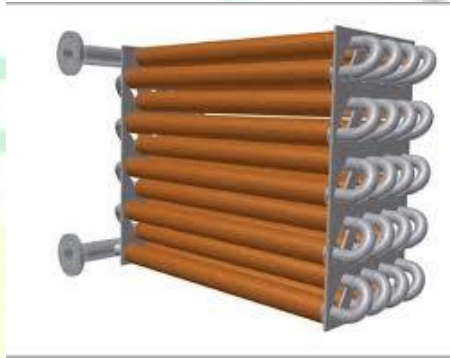

- Arrangement of feed water tubes located in an exhaust flue duct to absorb a portion of heat energy that would otherwise be lost in the stack.
- The choice between an air preheater and economizer is made on basis of draft losses, level of flue gas temperature, operating steam pressure, maintenance requirements etc.

### Air preheaters

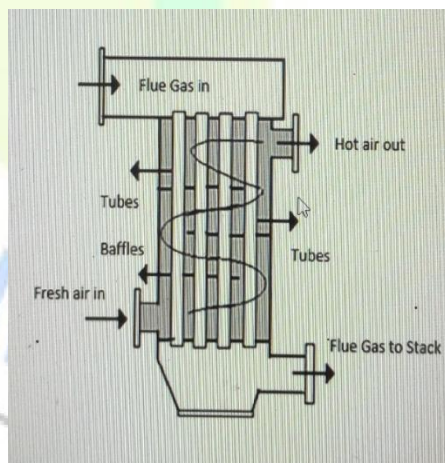

- Device designed to heat air before another process.
- They may be used alone or to replace a recuperative heat system or to replace a steam coil.
- Purpose of the air preheater is to recover the heat from the boiler flue gas which increases the thermal efficiency of the boiler by reducing the useful heat lost in the flue gas

### Turbulators

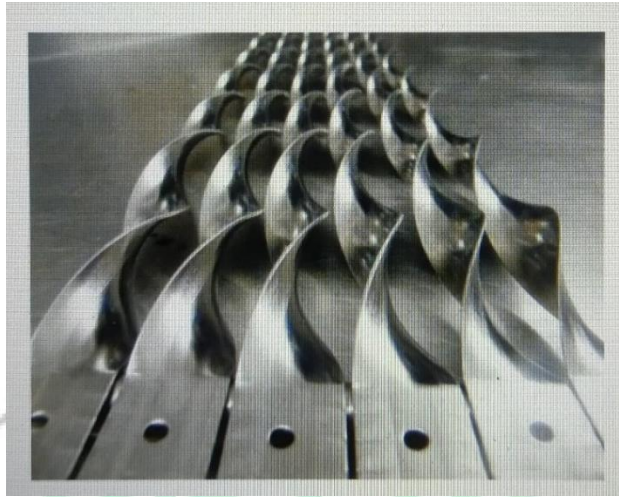

- Turbulators are inserted into heat exchanger tubing to increase the turbulent flow through a tube, effectively increasing heat exchange rates and abilities. Turbulators act to mix the fluid or gas on the inside of the tube.
- Cannot be used on coal-fired units

#### **Efficiency computation of Furnaces**

A furnace is an equipment to melt metals for casting or heat materials for change of shape (rolling, forging etc) or change of properties (heat treatment).

The efficiency of furnace can be judged by measuring the amount of fuel needed per unit weight of material.

The quantity of heat to be imparted (Q) to the stock can be found from

$$Q = m \times C_p (t_1 - t_2)$$

Where

Q = Quantity of heat of stock in kCal

m = Weight of the stock in kg

C<sub>p</sub> = Mean specific heat of stock in kCal/kg°C t<sub>1</sub> = Final temperature of stock desired, °C

t<sub>2</sub> = Initial temperature of the stock before it enters the furnace, °C

## Lesson 8

## Energy Conservation measures in Furnaces

- 1) Complete combustion with minimum excess air
- 2) Correct heat distribution
- 3) Operate furnace at the desired temperature
- 4) Reduce heat losses from furnace openings
- 5) Maintain correct amount of furnace draught
- 6) Optimum capacity utilization of furnace will give maximum thermal efficiency
- 7) Waste heat recovery from the flue gases improves system efficiency
- 8) Minimum refractory losses

The appropriate choice of refractory and insulation materials goes a long way in achieving fairly high fuel savings in industrial furnaces

- 9) Use of Ceramic Coatings in furnace chamber promotes rapid and efficient transfer of heat, thereby extended life of refractories.

**Thermic Fluid Heaters**

Thermic Fluid is used as a heat transfer mechanism in some industrial process and heating applications. Thermic Fluid may be a vegetable or mineral based oil and the oil may be raised to a high temperature without the need for any pressurization. The relatively high flow and return temperatures may limit the potential for flue gas heat recovery unless some other system can absorb this heat usefully. Careful design and selection is required to achieve best energy efficiency.

Thermic fluid heaters are used just to heat the water, not necessarily producing steam. Water is heated by passing hot thermic fluid in tubes submerged in water. This arrangement is similar to the fire-tube boiler

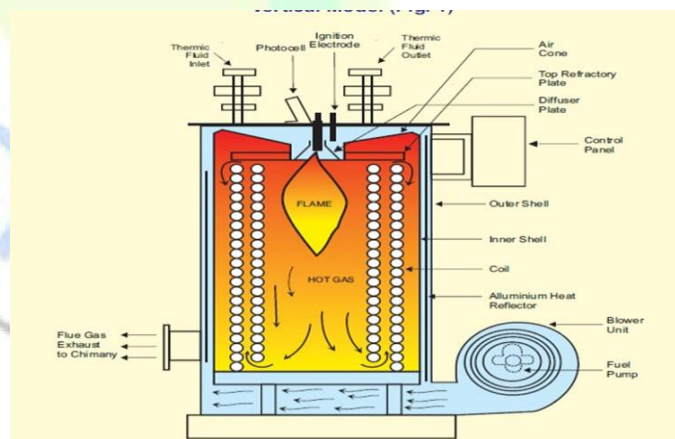

The combustion air enters through the fan inlet, travels upwards through the space between the inner shell & the outer shell, gets pre-heated & enters the top mounted burner. Hot flue gases travel down the full length of the vessel creating the first (radiant) pass. The flue gases then travel upwards through the space between the inner coil & the outer coil creating the second (convection) pass. The third (convection) pass is downwards through the space between the outer coil & the inner shell to the flue gas outlet.



**Steam: Concept, Properties & Usage**

Steam has been a popular mode of conveying energy since the industrial revolution. Steam is used for generating power and also used in process industries such as sugar, paper, fertilizer, refineries, petrochemicals, chemical, food, synthetic fiber and textiles.

The following characteristics of steam make it so popular and useful to the industry:

- Highest specific heat and latent heat
- Highest heat transfer coefficient
- Easy to control and distribute
- Cheap and inert

Water can exist in the form of solid (ice), liquid (water) and gas (steam) respectively. If heat energy is added to water, its temperature rises until a value is reached at which the water can no longer exist as a liquid. We call this the "saturation" point and with any further addition of energy, some of the water will boil off as steam. This evaporation requires relatively large amounts of energy, and while it is being added, the water and the steam released are both at the same temperature. Equally, if steam is made to release the energy that was added to evaporate it, then the steam will condense and water at same temperature will be formed.

**Steam Distribution**

- The steam distribution system is the essential link between the steam generator and the steam user.
- Whatever the source, an efficient steam distribution system is essential if steam of the right quality and pressure is to be supplied, in the right quantity, to the steam using equipment.
- Installation and maintenance of the steam system are important issues, and must be considered at the design stage.
- Link between the steam generator and the steam user
- Pressure in the steam distribution system is usually between 2 and 12 bar
- Success of any system is depending on meeting the end process steam pressure requirement of process plant
- Distribution system is influenced by the factors
  - maximum safe working pressure of the boiler
  - minimum pressure required at the plant

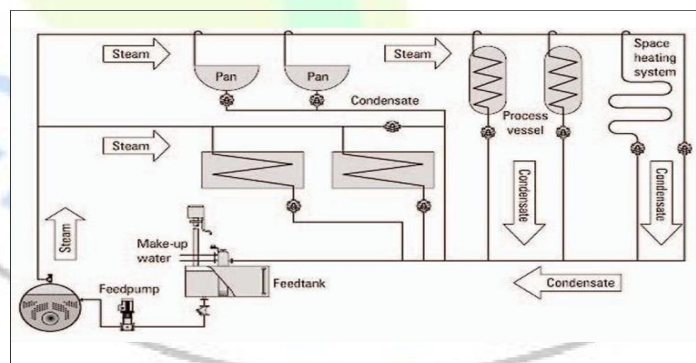

- As steam condenses in a process, flow is induced in the supply pipe.
- Condensate has a very small volume compared to the steam, and this causes a pressure drop, which causes the steam to flow through the pipes.
- The steam generated in the boiler must be conveyed through pipe work to the point where its heat energy is required.
- Initially there will be one or more main pipes, or 'steam mains', which carry steam from the boiler in the general direction of the steam using plant.
- Smaller branch pipes can then carry the steam to the individual pieces of equipment. A typical steam distribution system is shown in Figure

**3.9 Steam Traps**

The purpose of installing the steam traps is to obtain fast heating of the product and equipment by keeping the steam lines and equipment free of condensate, air and non- condensable gases. A steam trap is a valve device that discharges condensate and air from the line or piece of equipment without discharging the steam.

The three important functions of steam traps are:

- To discharge condensate as soon as it is formed.
- Not to allow steam to escape.
- To be capable of discharging air and other incondensable gases.

**Basically, two different types of steam traps:**

Thermal	Mechanical
1.capsule steam trap and bimetallic steam trap	1.float steam trap
2.based on the temperature difference between saturated steam and condensate that is somewhat cooled.	2.work from the basis that steam and condensate have different densities.

**STEAM CONSERVATION OPPORTUNITIES**

- Monitoring steam traps
- Avoiding steam leakages
- Providing dry steam for process
- Utilising steam at the lowest acceptable pressure for the process
- Proper utilisation of directly injected steam
- Minimizing heat transfer barriers
- Proper air venting
- Condensate recovery
- Insulation of steam pipelines and hot process equipment's
- Flash steam recovery

**EFFICIENCY PIPING LAYOUTS**

- The purpose of steam pipe circuit is to carry the steam generated by steam generator at a given pressure and supply to each steam using equipment in accordance with its requirement regarding quantity, quality and pressure
- In case of steam flow, condensate is formed in the pipe line also due to heat loss by steam
- Condensate has very less volume as compared to that of steam, so the formation of condensate also causes pressure drop along with pressure drop due to flow resistance

## ENERGY CONSERVATION AND MANAGEMENT

However theoretical values of pressure loss or head loss in single phase flow through pipes is given by D'Arcy equation

$$h_f = 4fLu^2/2dg$$

$h_f$  – head loss due to friction

$f$  – frictional factor

$L$  – corrected length of pipe

$u$  – mean flow velocity

$d$  - pipe diameter

- Based on all the above-mentioned factors and the quantity of steam flow rate required steam piping system is designed
- Initially there are one or more main pipes which carry steam from boiler to plant
- From the steam mains smaller branch pipes carry steam to individual equipment
- Branch pipes are always joined at the top of steam mains to avoid flow of condensate.

### Steam Pipes Insulation

- To bear the high pressure and temperature of steam, steam pipes are made of carbon steel
- If not insulated properly, the steam will lose a significant amount of its useful heat on the way to steam using equipment and will be direct loss of energy
- the pipes must be insulated properly to increase the heating efficiency of steam system
- Up to 90% of heat losses can be avoided by providing insulation
- There is a variety of materials that can be used to insulate steam pipes such as fiberglass, neoprene foam, polyethylene, mineral wool, calcium silicate etc
- The effectiveness of most of the insulation materials depend on minute air cells held in a matrix of insulation material
- These air-cells may be destroyed if insulation absorbs moisture
- aluminium cladding is provided over insulation
- Special shape insulation covers are available for other fittings also

### Types of Stem Traps

There are three basic types of steam trap into which all variations fall, all three are classified by International Standard ISO 6704:1982.

**1.Thermostatic (operated by changes in fluid temperature)** - The temperature of saturated steam is determined by its pressure. In the steam space, steam gives up its enthalpy of evaporation (heat), producing condensate at steam temperature. As a result of any further heat loss, the temperature of the condensate will fall. A thermostatic trap will pass condensate when this lower temperature is sensed. As steam reaches the trap, the temperature increases and the trap closes.

**2.Mechanical (operated by changes in fluid density)** - This range of steam traps operates by sensing the difference in density between steam and condensate. These steam traps include 'ball float traps' and 'inverted bucket traps'. In the 'ball float trap', the ball rises in the presence of condensate, opening a valve which passes the denser condensate. With the 'inverted bucket trap', the inverted bucket floats when steam reaches the trap and rises to shut the valve. Both are essentially 'mechanical' in their method of operation.

**3.Thermodynamic (operated by changes in fluid dynamics)** - Thermodynamic steam traps rely partly on the formation of flash steam from condensate. This group includes 'thermodynamic', 'disc', 'impulse' and 'labyrinth' steam traps.

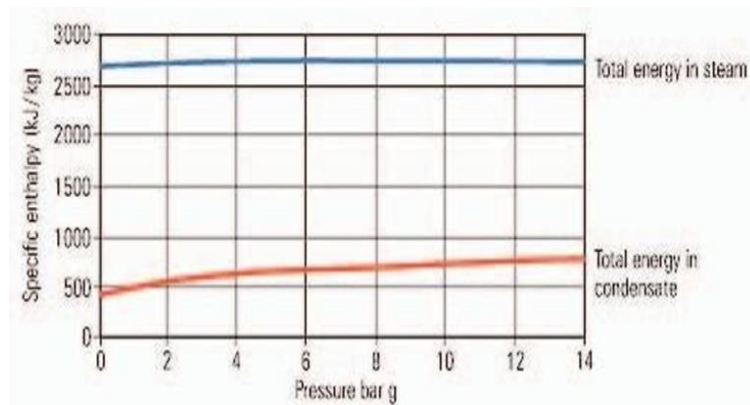

**Condensate Recovery****Heat Content of Steam and Condensate at the Same Pressure**

The steam condenses after giving off its latent heat in the heating coil or the jacket of the process equipment. A sizable portion (about 25%) of the total heat in the steam leaves the process equipment as hot water. Figure 3.3 compares the amount of energy in a kilogram of steam and condensate at the same pressure. The percentage of energy in condensate to that in steam can vary from 18% at 1 bar g to 30% at 14 bar g; clearly the liquid condensate is worth reclaiming. If this water is returned to the boiler house, it will reduce the fuel requirements of the boiler. For every 60°C rise in the feed water temperature, there will be approximately 1% saving of fuel in the boiler.

**Benefits of Condensate Recovery**

- Water charges are reduced.
- Effluent charges and possible cooling costs are reduced.
- Fuel costs are reduced.
- More steam can be produced from the boiler.
- Boiler blowdown is reduced - less energy is lost from the boiler.
- Chemical treatment of raw make-up water is reduced.

**Flash Steam Recovery**

Flash steam is produced when condensate at a high pressure is released to a lower pressure and can be used for low pressure heating.

The higher the steam pressure and lower the flash steam pressure the greater the quantity of flash steam that can be generated. In many cases, flash steam from high pressure equipment's is made use of directly on the low-pressure equipment's to reduce use of steam through pressure reducing valves.

The flash steam quantity can be calculated by the following formula with the help of a steam table:

$$\text{Flash steam available \%} = (S1 - S2) / L2$$

Where: S1 is the sensible heat of higher-pressure condensate.

S2 is the sensible heat of the steam at lower pressure (at which it has been flashed). L2 is the latent heat of flash steam (at lower pressure).

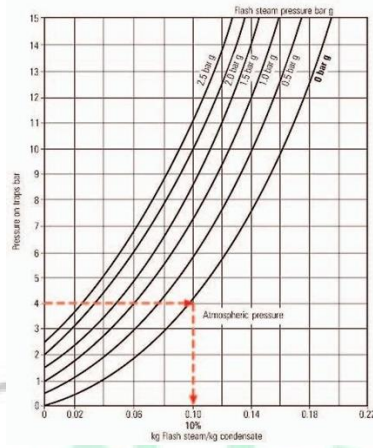

Flash steam can be used on low pressure applications like direct injection and can replace an equal quantity of live steam that would be otherwise required. The demand for flash steam should exceed its supply, so that there is no build-up of pressure in the flash vessel and the consequent loss of steam through the safety valve. Generally, the simplest method of using flash steam is to flash from a machine/equipment at a higher pressure to a machine/equipment at a lower pressure, thereby augmenting steam supply to the low-pressure equipment.

In general, a flash system should run at the lowest possible pressure so that the maximum amount of flash is available and the backpressure on the high-pressure systems is kept as low as possible.

Flash steam from the condensate can be separated in an equipment called the 'flash vessel'. This is a vertical vessel as shown in the Figure 3.5. The diameter of the vessel is such that a considerable drop in velocity allows the condensate to fall to the bottom of the vessel from where it is drained out by a steam trap preferably a float trap. Flash steam itself rises to leave the vessel at the top. The height of the vessel should be sufficient enough to avoid water being carried over in the flash steam.

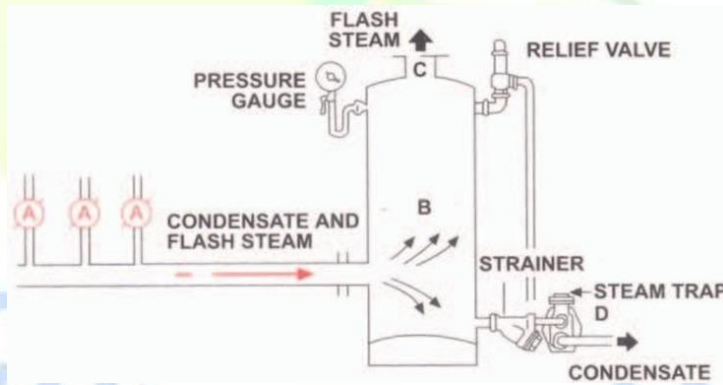

Figure Flash Steam Recovery

The condensate from the traps (A) along with some flash steam generated passes through vessel (B). The flash steam is let out through (C) and the residual condensate from

(B) goes out through the steam trap (D). The flash vessel is usually fitted with a 'pressure gauge' to know the quality of flash steam leaving the vessel. A 'safety valve' is also provided to vent out the steam in case of high pressure build up in the vessel.

**Lesson 9**

**Improving efficiency and energy conservation opportunities of thermal processes**

**Energy efficiency and conservation**

- Energy efficiency is the use of less energy to perform the same task or produce the same result
- Energy conservation is the effort to reduce wasteful energy consumption by using fewer energy services
- This can be done by using energy more effectively



**Thermal process**

Processes that employ heat to make food safe for consumption and extend shelf-life by reducing or eliminating microbiological contamination and enzymatic activity of the food

These processes could also affect texture and flavor of food products

Pasteurization and sterilization are two of the main processes for thermal processing

**Pasteurization**

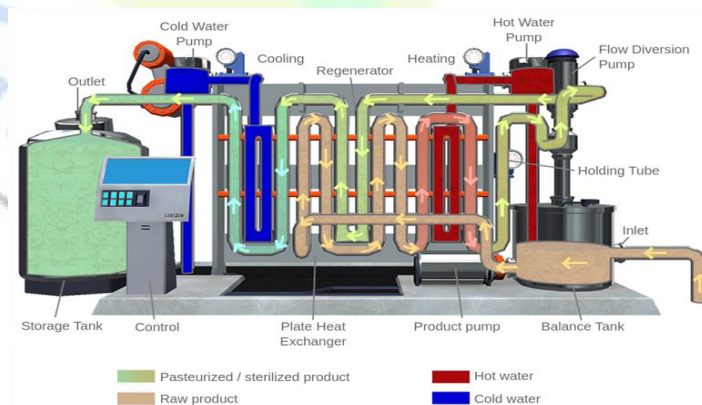

Process of heating every particle of milk to at least 63°C for 30 min or 72°C for 15s or to any temperature-time combination which is equally efficient, in a properly operated equipment and immediately cooling to 4°C or below.

- To render milk safe for human consumption by destroying all the pathogenic microorganisms



## ENERGY CONSERVATION AND MANAGEMENT

- To improve the keeping quality of milk by killing almost all spoilage organisms
- BATCH PASTEURIZATION

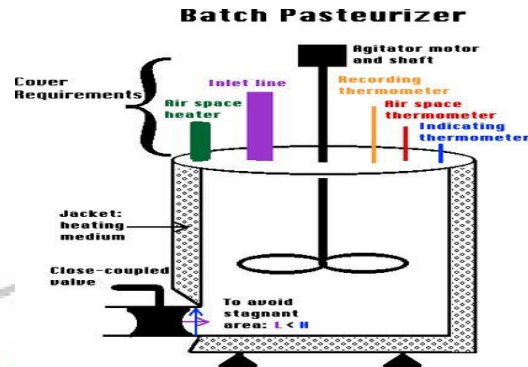

- Double jacketed vat
- Hot water or low-pressure steam is circulated through the jacket
- Heated to 62.7 C for 30 minutes
- Cooled to 4 C

## HTST PASTEURIZATION

- Continuous process
- Heated to 72°C for 15s
- Promptly cooled to 5°C or below.
- Plate Heat Exchanger (PHE) is commonly used

## ENERGY CONSERVATION OPPURTUNTIES

### 1. Energy audit

- Key approach for systematic decision making in process management
- It attempts to balance the total energy inputs with the output or the uses
- An audit team consist of qualified and experienced electrical and mechanical engineers and are accompanied by an expert

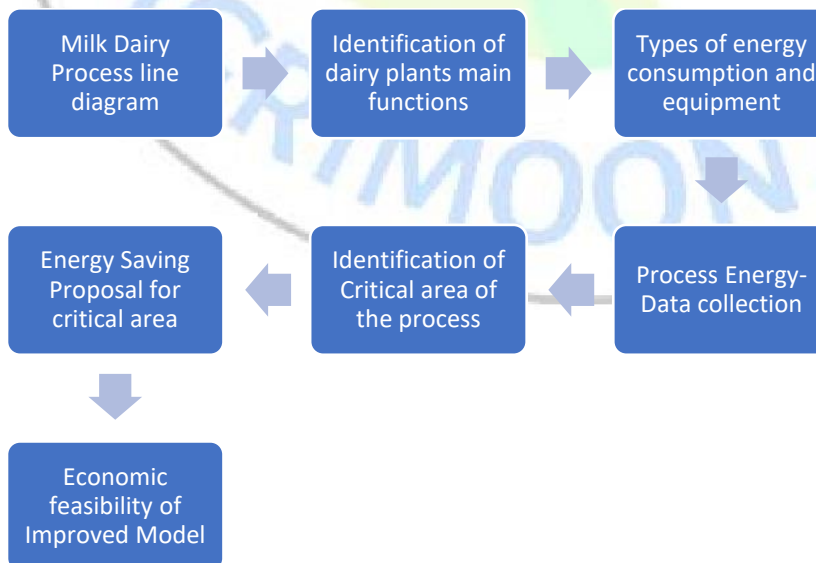

## 2. COGENRATION SYSTEM

## ENERGY CONSERVATION AND MANAGEMENT

- Sequential generation of two different forms of useful energy from a single primary energy source
- Pasteurizer requires both electricity and process heat
- Converts 70-90% of the energy in the original fuel to useful energy
- Heat rate of cogeneration is less than the heat rate of power plant
- Economically feasible

Cogeneration delivers significantly higher efficiency than traditional grid with central power plants.

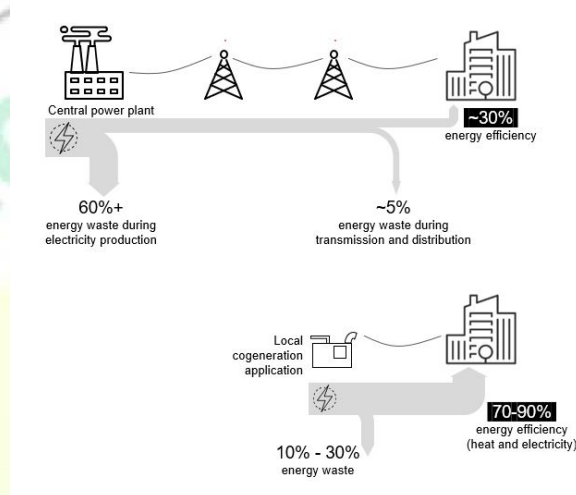

### 3. Plate Type Heat Exchanger

- Regenerative heating and cooling
- The raw chilled incoming milk is partially and indirectly heated by the heated outgoing milk (milk-to-milk regeneration)
- This adds to the economy, as the incoming milk requires less heating by hot water
- Pasteurized hot outgoing milk is partially and indirectly cooled by the incoming cold milk
- Heating load required for the purpose of milk chilling is reduced Recovery is 95%

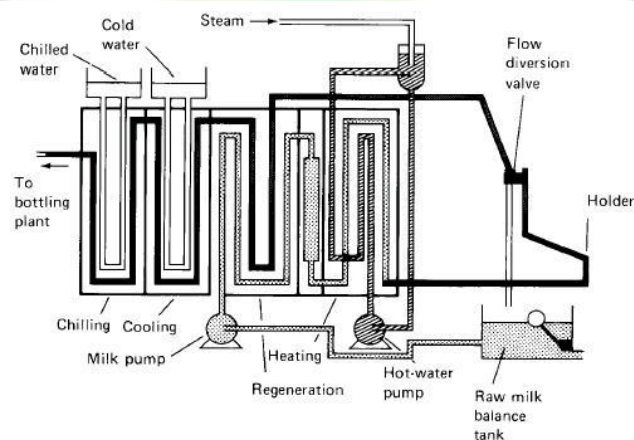

## CASE STUDY

- Plant running Capacity is 240000 liters (10000 Liters /hour) for 24 hours working

## ENERGY CONSERVATION AND MANAGEMENT

### Calculation of pasteurization process energy consumption

- Total power consumption of pasteurization process per day = 50818kw
- Total power consumption of pasteurization process per hour = 2117.4kw/hour
- Electricity unit cost for pasteurization process = Rs0.2117\*Rs2.63= Rs0.556
- Total milk production per hour = 10000litres

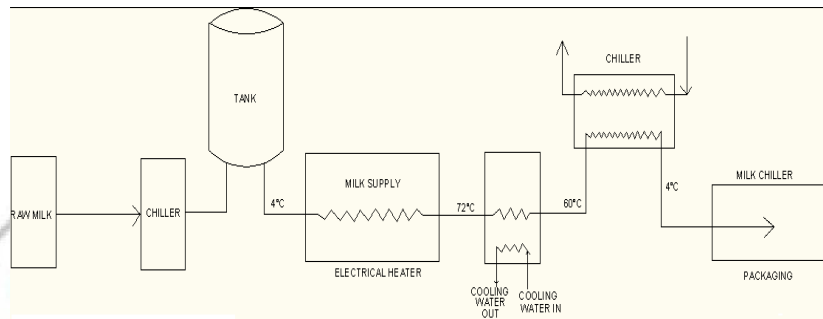

- **Alternative proposed was to use regenerative heating and cooling**
- Energy saving for pasteurization process by heating raw milk =  $3.93 \times 1.03 \times (72 - 28) = 178.10 \text{ kJ/liter}$
- Energy saving due to alternative system for 24 hours = 9498.48 Kw
- % energy saving = 18.69%
- Per liter saving =  $(0.556 \times 18.69) / 100 = \text{Rs } 0.1 \text{ per liter}$
- Per day saving =  $0.1 \times 240000 = \text{Rs } 24000 \text{ per day}$
- Saving Per month =  $24000 \times 30 = \text{Rs } 7, 20,000 \text{ per month}$

#### 4. Other methods

- By economizer to heat feed water for boilers, so use waste heat
- By proper integration of chilling system to the main process by load balancing
- To use waste heat of air compression outlet to heat boiler inlet water
- By proper loading of electrical motors and lightening system
- By using variable frequency drives in air compressors
- By proper maintenance of equipment

#### Sterilization

- Complete destruction or elimination of all viable organisms in/on a food product
- Sterilization destroys yeasts, molds, vegetative bacteria, and spore formers
- Allows the food processor to store and distribute the products at ambient temperatures, with extended shelf life
- Product must be heated to a temperature of 110 to 125°C and held at this temperature for few seconds
- Providing long-term preservation and a commercial sterility is the basic function





### Energy conservation opportunities

1. **Compact immersion tube heat exchanger**

- Consist of a combustion chamber and a heat exchange tube
- Exhaust from the combustion chamber is circulated directly through the immersed tubes, which transmit heat to the water in the reservoir
- Hot water is then circulated to another heat exchanger
- 35% less energy than centralized water heating systems

2. **Induction heating of liquids**

- Induction heater works by dissipating the energy generated when the secondary winding of a transformer is short-circuited
- Instantly imparts heat to liquid circulating in a coil around the transformer core
- Energy savings compared to boiler-based methods of liquid heating have been estimated at up to 17%

3. **Helical heat exchangers**

- Increased heat transfer rates
- Reduced fouling
- Reduced maintenance cost

4. **Heat exchanger enhancement techniques**

- Eliminate fouling
- Fouling can increase energy consumption of a dairy plant by up to 8%
- Fouling layer can be removed during the CIP stage, if the proper cleaning chemicals and techniques are used

### Improving efficiency and energy conservation opportunities of freezing



### Introduction

The energy saving opportunities for each unit operations include three aspects:

- Improvement of energy efficiency in existing units
- Replacement of energy-intensive units with novel units
- Use of renewable energy sources, particularly food processing wastes



### Freezing

- 1) Best practice
- 2) Improved insulation
- 3) Novel and innovative technologies

#### 1. Best practice

- Proper maintenance and waste heat recovery
- Installation, maintenance, and operation of doors
- A large portion of the energy losses is caused by the inefficient heat exchange in evaporators and condensers
- It is technologically feasible and economically practicable to install heat exchangers to recover heat from refrigeration condenser coils, water towers, and compressor rooms
- The optimization of the defrost cycle is desirable and practicable.

#### 2. Improved methods

- The selection of a freezer can have an important effect on energy consumption
- The fans of air blast chillers or freezers add a heat load to chillers or freezers during operation
- Since the heat generated by fans increases with the required air load, it is critical to optimize the air velocity to minimize the heat generation and maximize the refrigeration effect during air blast chilling or freezing of food products.

### Vacuum cooling

Rapid evaporative cooling technique

Achieved through evaporating part of the moisture of the product under vacuum

- Shorter processing time
- Extended product shelf life
- Improved product quality and safety

### Vacuum cooling process

- An airtight chamber is maintained by removing air from the inside of the chamber using a [vacuum pump](#)
- The products to be cooled are kept in that airtight chamber

## ENERGY CONSERVATION AND MANAGEMENT

- As the pressure is reduced the boiling point of water reduces and water starts to evaporate, taking heat from the product
- As a consequence of this evaporation, the product temperature begins to decrease. This cooling process of the products continues until it reaches the desired product temperature.

Vacuum  
Pumping  
Controls

chamber  
system



## Applications

- 1) Fishery products
- 2) Fruits and vegetables
- 3) Meat products
- 4) Bakery products

## Ultrasonic assisted food freezing

### Novel fast freezing technique developed in recent years

- The propagation of ultra-sound in a medium generates various physical and chemical effects and these effects have been harnessed to improve the efficiency of various food processing operations.
- Used in meat, fruit, vegetables and ice cream
- **Application in food freezing**
- Initiation of ice nucleation
- Improving the freezing rate
- Control of size and shape of the ice crystals
- Improving the quality of frozen food

## High pressure freezing

- Food is cooled under high pressure to sub-zero temperatures but does not undergo a phase change and freeze until the pressure is released
- Rapid nucleation results in small, even ice crystals. Thus, nucleation theoretically occurs instantaneously and homogeneously throughout the food.
- Reduced duration of phase transition
- Less mechanical stress during formation of ice crystals

## Other techniques

Magnetic resonance assisted freezing

Microwave assisted freezing



## ENERGY CONSERVATION AND MANAGEMENT

Electrostatic assisted freezing

Radio-frequency assisted freezing

### Improving efficiency and energy conservation in evaporation

#### Evaporation

- A widely used method for the concentration of aqueous solutions
- It involves the removal of water from a solution by boiling the liquor in a suitable vessel, an evaporator, and withdrawing the vapour
- If the solution contains dissolved solids, the resulting strong liquor may become saturated to that crystals are deposited

#### Factors affecting evaporation

- Temperature
- Vapour pressure
- Surface area
- Density
- Type of product
- Agitation
- Time of evaporation
- Economic factors
- Moisture content

#### Energy efficiency measures for evaporation

Some of the methods applied for **increasing the efficiency and minimizing the energy consumption** of the evaporation plants include

Multiple effect arrangement

- 1) Usage of waste energy
- 2) Membrane filtration
- 3) Mechanical vapour recompression
- 4) Thermal vapour recompression

#### Maintenance

#### Common sources of inefficiency and heat loss in evaporators include

- Excessive venting
- Radiation and convective losses
- Poor vacuum system performance
- Air and water leakage
- Fouling
- Poor separator efficiency

## ENERGY CONSERVATION AND MANAGEMENT

- **An ongoing maintenance program for evaporators can help minimize and avoid many of these sources of energy loss**

**In general, a solid maintenance program should include the following**

- Inspection and prevention of air leaks into evaporators to minimize venting rates (air is non-condensable and thus must be vented from the system)
- Cleaning of heat transfer surfaces to allow efficient transfer of energy
- Inspection and replacement of wet, damaged, or decayed insulation
- Cleaning of vapor separation vessels to maintain product yields and pressure profiles
- Inspection and prevention of water leaks into the system to avoid diluting the product streams
- Maintaining the optimum pressure profile in the evaporator per the manufacturer's specifications (excess pressure inhibits evaporation by raising the boiling point)

### Multiple effect evaporators

- In multiple effect evaporators, the hot vapor that boils out of the liquid in one evaporator (effect) is used as the heating medium in another effect, which is operated at a lower pressure
- By using multiple effects, the amount of water evaporated per pound of steam supplied to the evaporator system can be increased
- The first effect has the highest boiling temperature, while the last effect has the lowest
- Each successive effect uses the vapor from the previous effect as a heat source

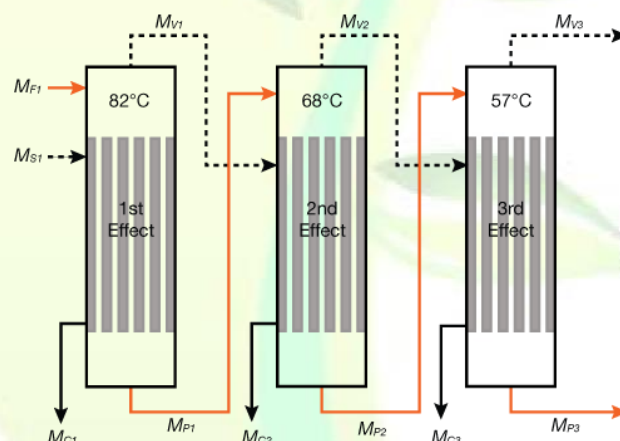

- There is practical limit to the number of effects that can be used for any given product application
- In practice, up to five effects might be feasible for evaporator systems used in dairy processing
- For whey production, a good rule of thumb is that each additional effect increases investment cost by 15% and decreases steam consumption by 25%

### Vapor recompression

- Energy efficiencies higher than that of multiple effect evaporator systems can be realized using Vapor recompression systems, in which the vapors exiting the evaporator are compressed and reintroduced into the evaporator as a heating medium
- There are two types of vapor recompression systems available
- Thermal Vapor Recompression (TVR) systems
- Mechanical Vapor Recompression (MVR) systems

### Thermal vapor recompression

## ENERGY CONSERVATION AND MANAGEMENT

- The vapors exiting the evaporator are compressed in a steam ejector using high pressure steam (0.8-2.1 MPa)
- The mixture is reintroduced into the same evaporator unit as a heating medium
- Part of the vapors exiting the evaporator must be removed in order to maintain the proper mass balance of steam entering the evaporator unit

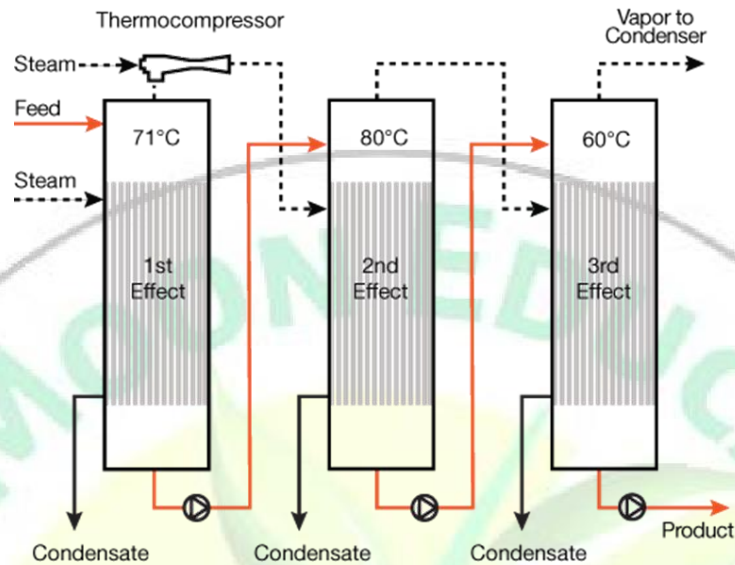

**A Thermo compressor raises the saturation temperature of the vapor exiting an effect to be reused to heat the next effect**

### Mechanical vapor recompression

- The vapors exiting the evaporator are compressed mechanically typically using centrifugal compressors or turbo fans
- Then reintroduced into the evaporator unit as a heating medium
- A small amount of heating steam is added to the system to make up the condensate formed during compression of water vapors
- MVR improves steam economy by compressing low pressure steam exiting the evaporator and recycling it as the heat source

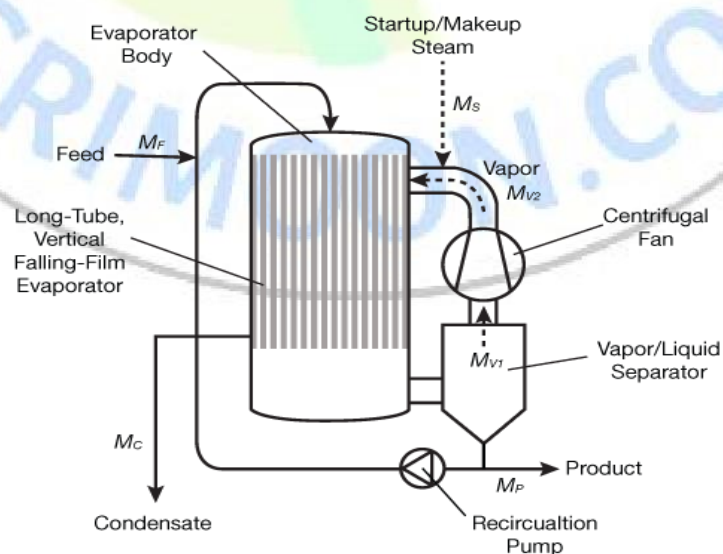



## ENERGY CONSERVATION AND MANAGEMENT

- Because of compression limitations and the high costs of evaporation under vacuum, vapor recompression units are mainly applicable where the product is not too concentrated and can be boiled under atmospheric or moderate vacuum conditions
- TVR systems are most economical when high-pressure steam is available at low cost, while MVR systems are most economical when electricity is available at low cost

TYPE OF EVAPORATOR	STEAM ECONOMY (Kg Water/Kg Steam)
Single Effect	0.90-0.98
Double Effect	1.7-2.0
Triple Effect	2.4-2.8
Six Effect	4.6-4.9
Triple Effect with TVR	4-8
Single Effect MVR	10-30

### Concentration using membrane filtration

- It is a more energy efficient option for moisture removal than traditional steam-based evaporation methods
- Membrane filtration systems have been successfully applied to the concentration of dairy products
- Most common types of membrane filtration systems used in the dairy processing industry are Reverse Osmosis and Ultra Filtration systems

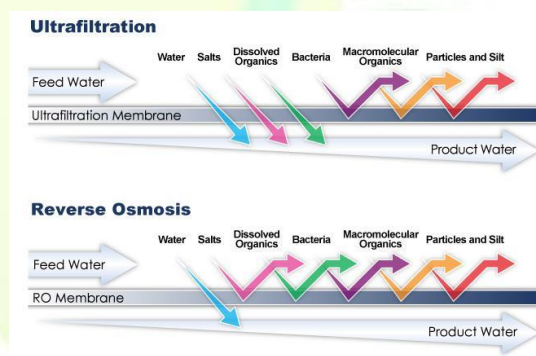

### Conclusion

- The primary means of increasing the steam economy of an evaporator is to reuse the latent heat of the water vapor
- A multiple-effect evaporator uses the water vapor from one effect as the heating medium for the next effect, which operates at a lower boiling point
- The latent heat in water vapor can also be reused by thermally or mechanically compressing the vapor to a higher pressure and temperature
- These methods of improving efficiency have their limits, however, which are specific to the physical properties of the liquid feed being evaporated

## Improving Efficiency and Energy Conservation Opportunities in Food Drying

### Food Drying

- Energy- intensive operation
- Indispensable technique in long-term food preservation

## ENERGY CONSERVATION AND MANAGEMENT

- To remove moisture from a food product up to a particular level by careful application of heat

### Benefits of Food Drying

- Storage stability
- Storage stability
- Reduced transportation load

### Characteristics of ideal drying process:

- Cost effective
- Reduced (or no) damage to product
- Reduced energy consumption
- Shortens drying time
- Hybrid Drying Technology
- Combination of two or more drying processes which offers synergistic effect
- Merges advantages of two or more drying techniques.
- Reduced energy demand
- Retains quality attributes
- Diminished drying time

#### Sun Drying

- Traditional technique
- Uses solar energy by direct exposure for preservatory effect
- Has many short-comings

#### Solar Drying

- Eco-friendly process
- Drying in closed chambers using solar insulation
- Simple technology
- Easy assembly

#### Solar Hybrid Drying Technology

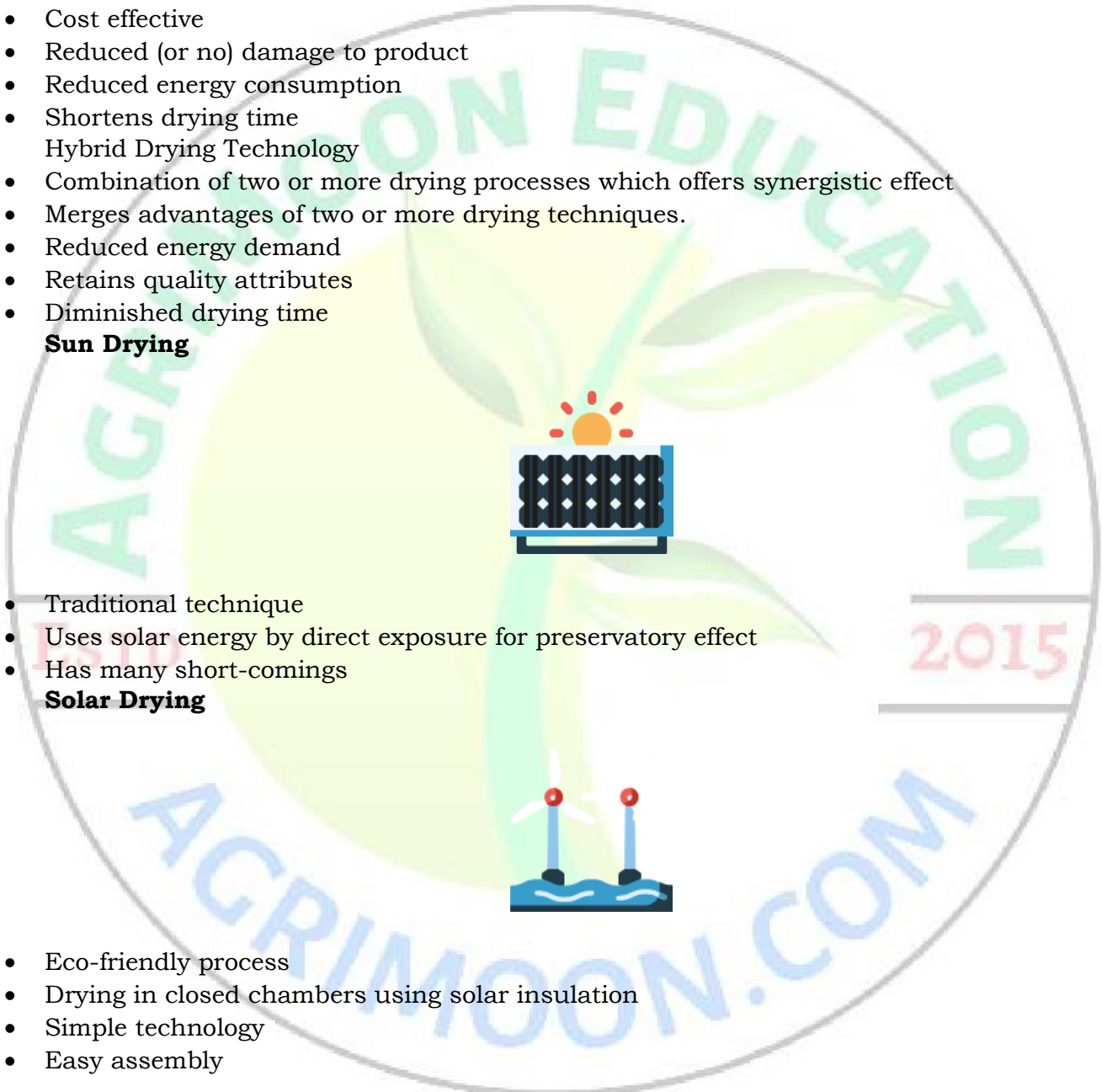

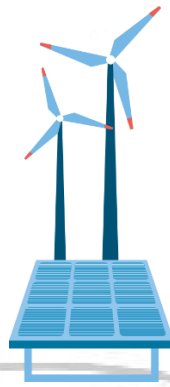

Alternative system for quick solar drying

- Solar + Fluidized bed drying
- Solar + Desiccant bed drying
- Solar + Desiccant bed drying
- Solar + Photocatalytic closed-type drying

### Liquid Desiccant assisted solar drying

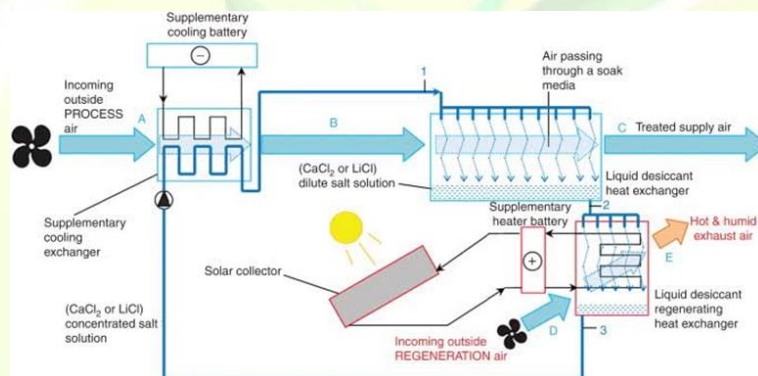

- Equipped with a photovoltaic regeneration system for drying at various temperatures and RH

Unit consists of

- Indirect solar dryer
- Liquid desiccant bed
- (Calcium Chloride solution)
- Desiccant regeneration system

### Working of desiccant regeneration system

- Exhaust air of drying chamber passes over desiccant bed
- Part of air humidity absorbed by desiccant
- Diluted desiccant pumped to distribution pipe
- Desiccant fed uniformly on panel surface and gets concentrated
- Conveyed back to desiccant chamber by return pipe

### SAIIR (Solar Assisted Intermittent Infrared Dryer)

- Powered by a photovoltaic-thermal system
- Amount of airflow in the photovoltaic system is controlled by a fan
- The power of the fan was supplied directly from photovoltaic panels
- Remaining electric energy is transferred to an IR radiation source for drying the product



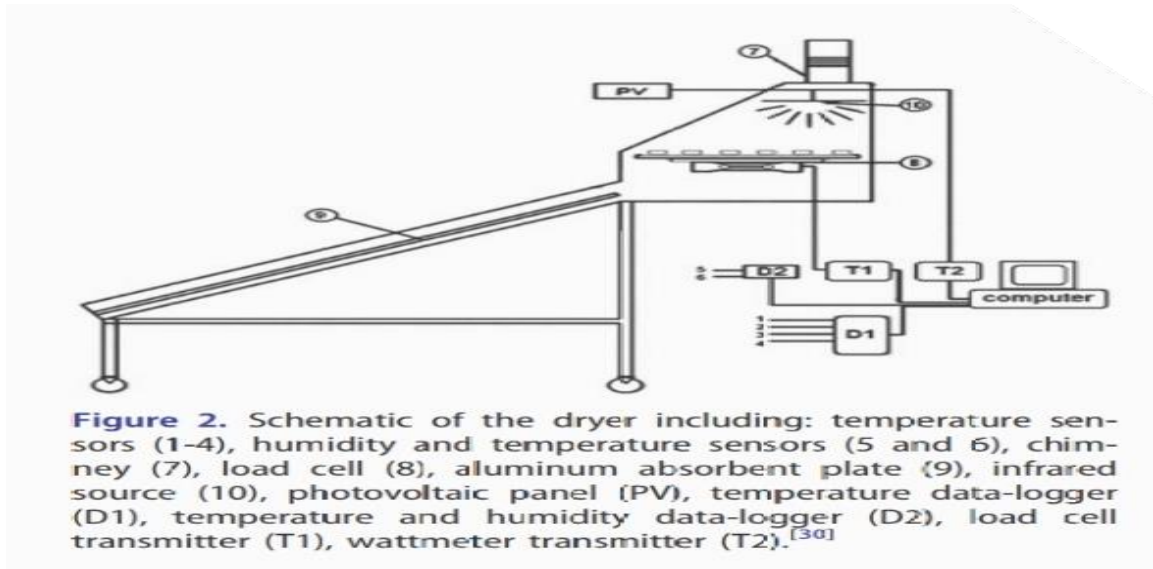

**Figure 2.** Schematic of the dryer including: temperature sensors (1-4), humidity and temperature sensors (5 and 6), chimney (7), load cell (8), aluminum absorbent plate (9), infrared source (10), photovoltaic panel (PV), temperature data-logger (D1), temperature and humidity data-logger (D2), load cell transmitter (T1), wattmeter transmitter (T2).<sup>[30]</sup>

**SHRAIRD**

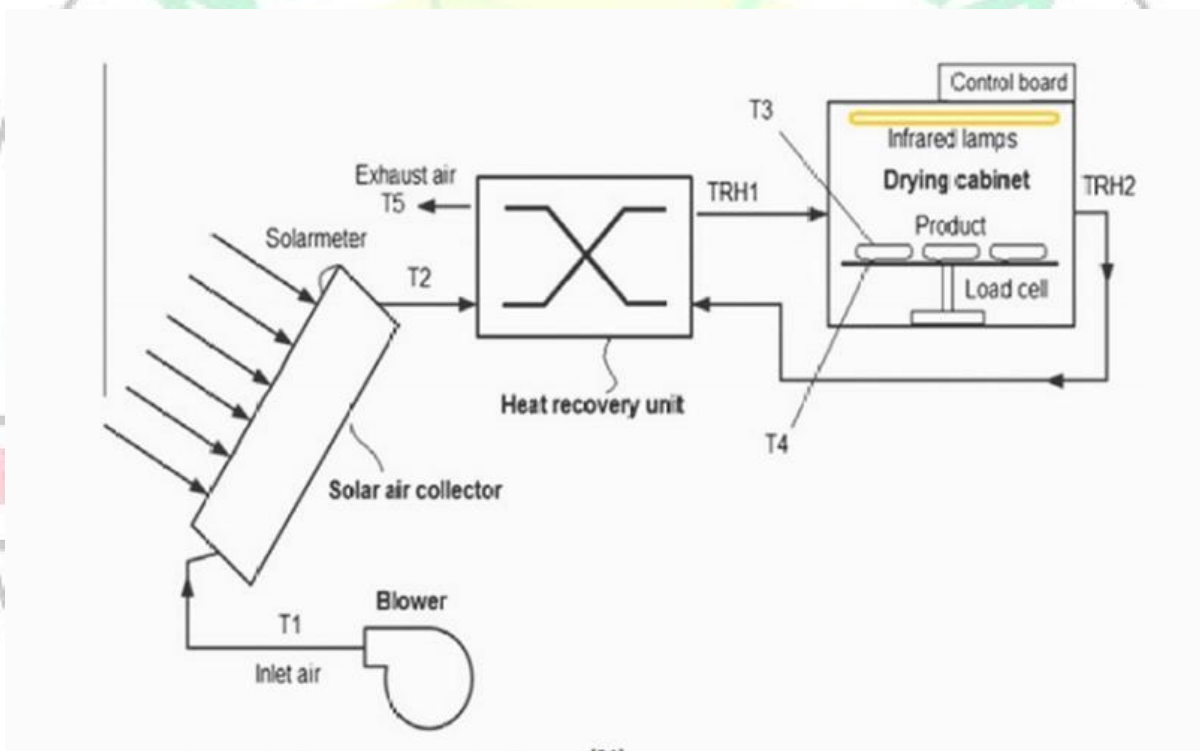

**Solar Heat Recovery Assisted Infrared Dryer**

A new prototype machines

Consists of 3 main parts:

- Solar Air Collector (SAC)
- Recovery Unit
- Drying cabinet

**Infrared Assisted Drying Technologies**

- IR +Freeze drying
- IR+Microwave drying
- IR+Hot Air drying
- IR+Hot Air drying

**Mechanism of IR Drying**

## ENERGY CONSERVATION AND MANAGEMENT

- IR rays enter into wet sample and raise temperature
- Diffusion rate of water increases
- Moisture content decrease due to diffusion to outside air
- Radiation properties of sample changes

### Comparison

Definition of process	Drying temp, IR intensity	Pre-Drying Time
Single- stage of freeze drying	-	-
Hot air pre- and freeze finish drying	60°C	3 h
Hot air pre- and freeze finish drying	80°C	3 h
Infrared pre- and freeze finish drying	60°C , 5 kWm <sup>2</sup>	3 min
Infrared pre- and freeze finish drying	60°C , 5 kWm <sup>2</sup>	4 min
Infrared pre- and freeze finish drying	60°C , 5 kWm <sup>2</sup>	5 min

### IR- Microwave Dryer

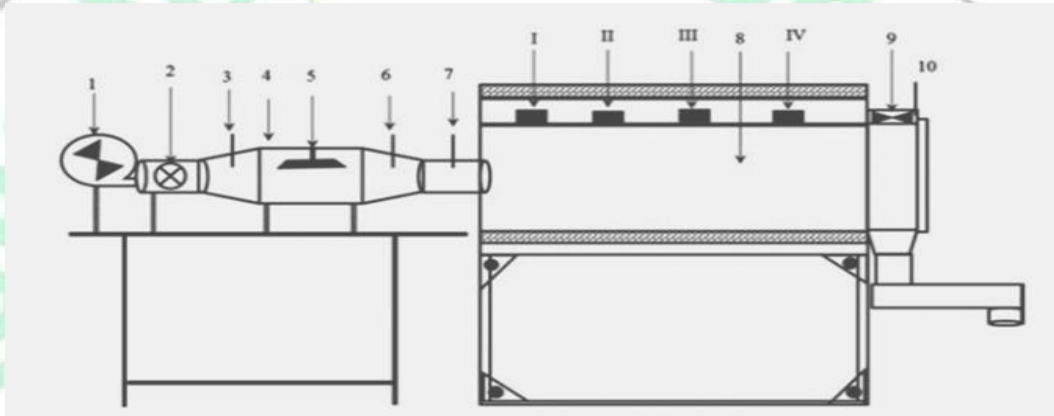

### Setup consists of 2 sections:

- Air heating section
- Microwave drying chamber with perforated trays

Components include:

- Air blow system
- Airflow control valve
- Inlet air temperature sensor
- Air heating chamber
- IR lamp
- Outlet air temperature sensor
- Anemometer
- Drying chamber
- Exhaust fan
- Air temperature and RH sensor

### Microwave Freeze Drying

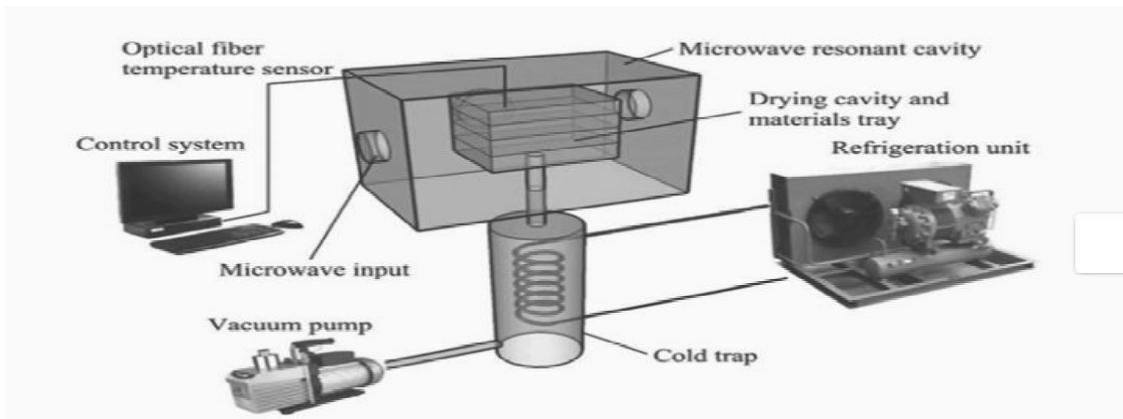

Frozen material is placed inside a cavity

Cavity is excited and microwave energy is dissipated by material to provide needed energy for sublimation

### US-CHAD or Ultra-Sound

Convective Hot Air Drying

- Non- thermal hybrid drying technique
- Applied for drying fruits and vegetables in continuous process
- Combination of US and CHAD can be associated to sound transmission in air, liquid or solid

#### Mechanism of US drying

- Generated acoustic energy results in periodic pulsations and velocities
- Water molecule bonding with product surface is broken
- Cavitation occurs
- Diffusion from within product to boundary layers

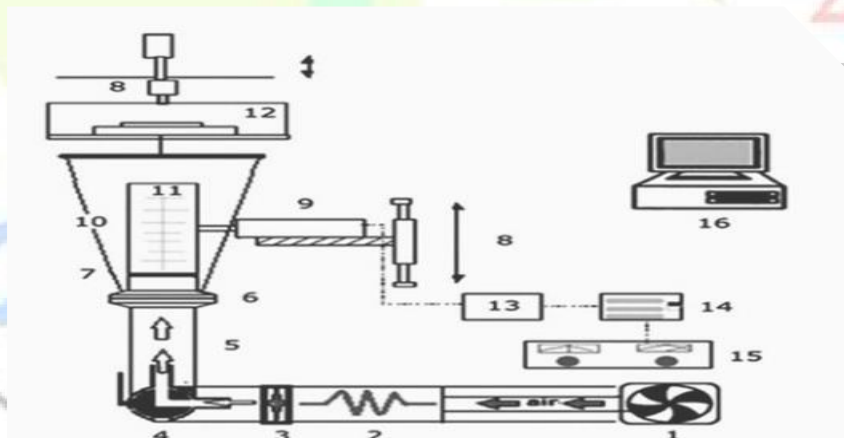

4. Fan; 2. Heating unit; 3. Anemometer; 4. Valves; 5. Thermocouple; 6. Sample loading chamber; 7. Coupling material; 8. Pneumatic system; 9. US transducer; 10. Vibrating cylinder; 11. Drying trays; 12. Weigh balance; 13. Impedance matching unit; 14. Digital power meter; 15. Power US generator; 16. PC

#### Miscellaneous Hybrid Drying Techniques

- Fluid bed & heat pump series
- CO<sub>2</sub> drying
- PEF drying



## ENERGY CONSERVATION AND MANAGEMENT

- USV
- Osmotic dehydration
- CUFIR

## ROLE OF STEAM TRAPS IN ENERGY SAVING

### STEAM TRAPS

- Steam-based heating use latent heat and transfer it to product
- When the work is done, steam condenses
- Condensate does not have the ability to do the work that steam does
- Heating efficiency will suffer if condensate is not removed
- So, condensate has to be removed as soon as possible
- 

**STEAM TRAP**

Automatic valve that filters out condensed steam and non-condensable gases such as air without letting steam escape

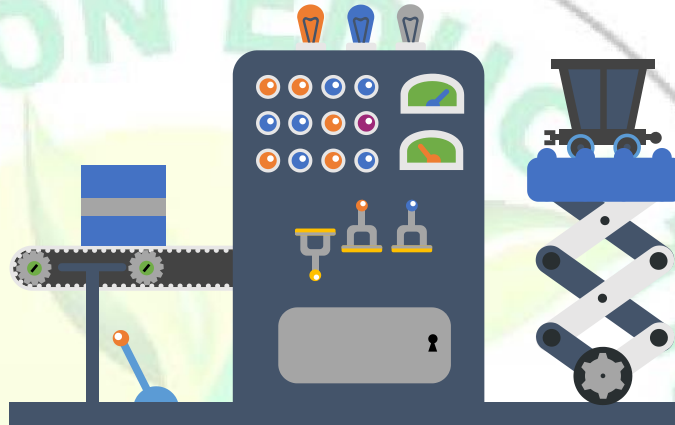

### Why Steam Trap Over Normal Valve?

Valve opening set to discharge a fixed amount of fluid means that fluctuations in the load of condensate cannot be compensated for

#### Equipment

Load of condensate at start-up differs during normal operation

#### Steam

Condensate generated in a given system is not fixed

#### Load

Fluctuation in the load of condensate

#### Condensate Load < Valve Opening

Steam loss

#### Condensate Load > Valve Opening

Condensate formed will pool inside and decrease in heating efficiency

#### Steam Transporation

Condensate load may differ depending on outdoor air temperature, heavy rain or snow

#### Mechanical Traps

- Operate on the principle of specific gravity
- The valve opens and closes due to the movement of a float that rises and sinks with the flow of condensate.

## ENERGY CONSERVATION AND MANAGEMENT

- Able to operate in precise response to the flow of condensate without their performance being compromised by most external factors
- They are of two types;

- 1) Float trap
- 2) Inverted bucket trap

### **Inverted Bucket Trap**

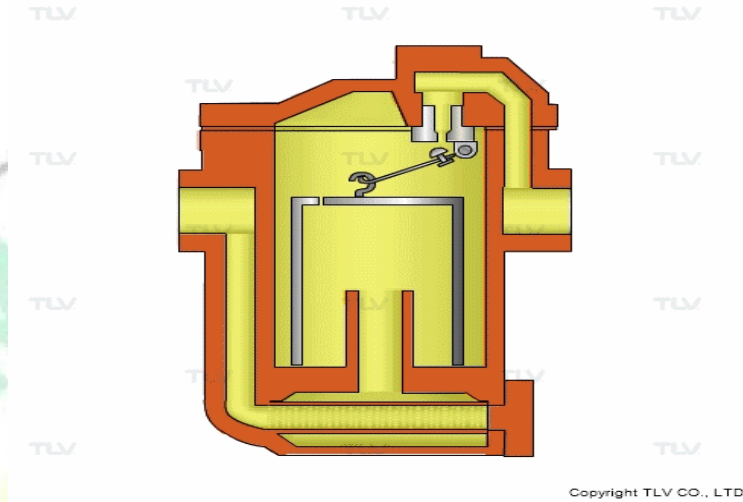

### **Disadvantages of Inverted Bucket Trap**

#### **Air vent hole**

Which release air very slowly as it is small

#### **Check Valve**

Applications having pressure fluctuations should have check valve

#### **Water level**

Requires minimum water level, to for the bucket to be buoyant otherwise causing steam loss

#### **Super-heated steam**

Needs check valves so as not to lose water seal property

### **Disadvantages Of Inverted Bucket Trap**

#### **Freezing**

Damage if installed in subzero ambient conditions

#### **Pressure difference**

Orifice meant to work up to certain maximum differential pressure

### **Advantages of Inverted Bucket Trap**

1. Withstand high pressure
2. Tolerate water hammer conditions
3. Can be used for super-heated steam with check valve at inlet
4. Failure mode is usually open
5. Can tolerate back pressure
6. Valve located far from area of dirt formation

## ENERGY CONSERVATION AND MANAGEMENT

7. Made of corrosion resistant materials
8. Uses energy conservation concept

### Float Trap

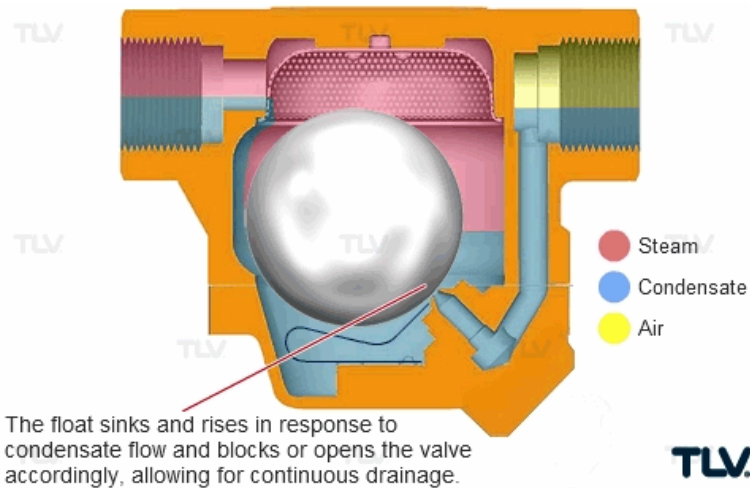

### Float Trap with Thermostatic Bellow

- Thermostatic bellow is located on the steam side
- Bellow closes on sensing high temperature from steam
- Over time, non-condensable gases and air collects at the top having much lower temperature
- Thus, the bellow opens and release the mixture of steam, non-condensable gases and air

### Advantages of Float Trap

1. Continuous discharge
2. Handle light or heavy condensate load
3. Large capacity to size
4. Resistant to water hammering

### Disadvantages of Float Trap

#### Freezing

Can be damaged by severe freezing

#### Pressure difference

Different internals are required to allow operation over varying pressure ranges

## HOT AIR GENERATOR, THERMIC FLUID HEATER, STEAM RADIATOR

### HOT AIR GENERATORS

- Hot air generators are equipment intended for heating any type of premises where a fast and efficient heating system is required.
- Its operation is based on carrying out combustion in a home and the gases produced pass through a heat exchanger where heat transfer is carried out with the air driven by a fan
- The hot air is distributed in the room to be heated, achieving comfortable comfort temperatures and extremely quickly compared to other heating systems.
- This system is completely autonomous and does not require heat dissipating elements, such as radiators, fan coils, etc.
- This is a great advantage because the installation and maintenance costs are much lower.

### Fuels



## ENERGY CONSERVATION AND MANAGEMENT

- The fuels used by hot air generators can be: diesel, natural gas, propane gas, woody waste, pellet

### Installation needs

- a) Single phase or three phase power supply according to the model.
- b) Fuel tank or gas connection.
- c) Fireplace to evacuate combustion gases outside the enclosure.
- d) Air supply ducts if you want to heat more than one room.

### ADVANTAGES

1. Fast and homogeneous heating
2. Decreases ambient humidity
3. Very low repair and maintenance costs.
4. Very low acquisition and installation prices.
5. It can be used as ventilation in summer.

### Main applications

- Hot air generators can be used in any type of industrial, commercial, agricultural or livestock installation, as well as being widely used equipment in low and high temperature drying processes.

### THERMIC FLUID HEATERS

- **Thermic Fluid Heaters** are heating equipment, used in industry where heat transfers are primary need of process instead of pressure
- **Thermic fluid heating system** generally used in a system where the pressure is not desired in a process and temperature requirement is higher and using the boiler for high-temperature services may increase the cost of a project.
- **Thermal Fluid Heaters** can improve process consistency and reduce downtime leading to a further increase in profitability.

### INDUSTRIAL APPLICATIONS

- Used to generate heat in various process industries, such as:-
- Food processing industries
- Rubber and plastics industries
- Publishing and print industries
- Metal fabrication and finishing plants
- Paper industries
- Textile industries
- Natural gas processing plants
- Crude oil extraction and processing industries.
- Chemical Industries
- Plywood and Laminates

## ENERGY CONSERVATION AND MANAGEMENT

- Confectionery

### THERMIC FLUID HEATER DESIGN

#### Construction Design

- Thermic fluid heater, **consists of two concentric coils** in which inner coil acts as a radiation zone and outer coil act as a convection zone.
- Flue gas velocity is generally higher between the 2 coils and between the coil and the outer shell, so higher the velocity higher will be the convective heat transfer between the flue gas and fluid.
- Thermic fluid heaters can be made either 3 pass or 4 passes depending on the design of thermic fluid heater and the type of fuels to be burnt. The efficiency of the heater increases with an increase in the number of passes.
- The **maximum temperature of 350°C of thermal fluid** can be achieved
- For every 100°C rises in the fluid temperature, the volume of fluid increases by 7% so expansion tank is added to take care of that extra volume.
- Deaerator tank is combined with the expansion tank and is generally used to vent out air from the fluid which acts as resistance in transferring heat to the fluid.

#### THERMIC FLUID HEATER FUELS

- **Solid Fuels:** Wood, Coal, Petcoke, Rice husk, etc.
- **Liquid Fuels:** Light Diesel Oils, Heavy Oils, etc.
- **Gaseous Fuels:** Natural Gas, Liquefied Petroleum Gas, etc.

#### ADVANTAGES

- High Capacity Heating System
- High System Efficiency – Reduced operating cost.
- Best applicable for High-Temperature Heating
- Can attain temperatures up to 300°C
- Can operate on the variety of fuels as per local availability
- Failsafe design and dependable safety instruments
- Rugged design and superior construction

#### STEAM RADIATOR

- One of the oldest types of radiators and are still commonly used today.
- Steam radiators are connected to a boiler given the task of heating up water.
- The boiler heats water until it forms into steam.
- The steam then travels up through the vertical pipe to the radiator where the thermal energy is given off through the fins.
- As the heat is lost from the steam, it slowly begins to turn back into water.
- Eventually the steam becomes water and flows back down into the boiler for heating once again

## ENERGY CONSERVATION AND MANAGEMENT

- The cycle of heating and cooling repeats over and over again in order to spread heat to the rest of the home.

### TYPES

#### **Cast-Iron free-standing systems:**

- The oldest version of a radiator heater, the cast-iron system is very efficient at heating up the room.
- It takes up the most amount of room, and takes the longest to heat up.
- Despite these two obvious downsides, the way it's designed allows the cast-iron system to also hold that heat for the longest period of time.

#### **Baseboard steam systems**

- This type of steam radiator works on the same premise of steam rising and condensation falling, however, they take up very little room in home.

#### **Ceramic systems**

- The newest version of a steam radiator.
- It's not hot when you touch it and it's more efficient at supplying sustainable heat.
- If you were going to choose a steam radiator to heat your home, this would be the one you should look for

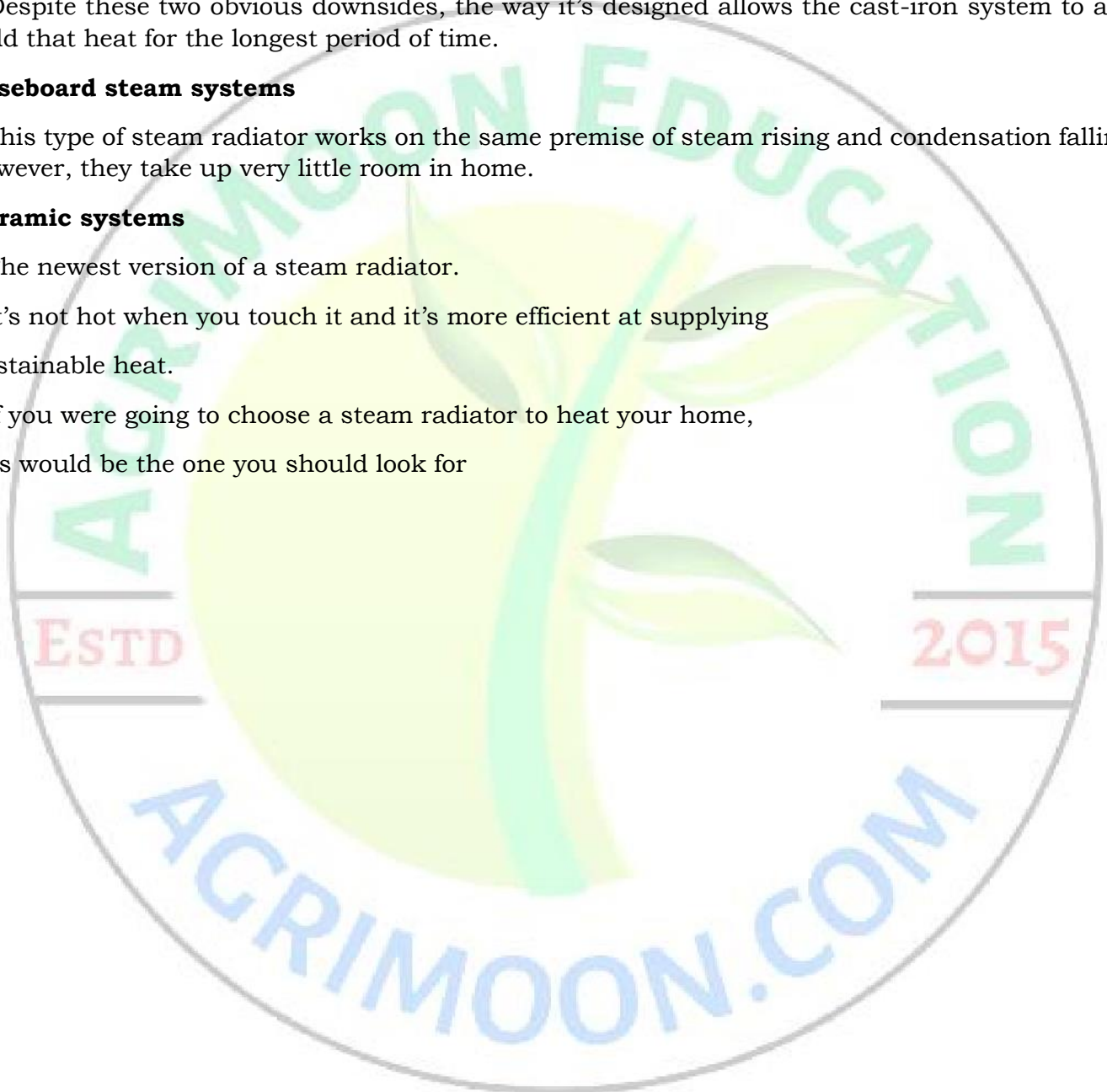



Lesson 10

ENERGY CONSERVATION IN BUILDINGS: CONCEPTS OF GREEN BUILDINGS

ENERGY CONSERVATION IN BUILDINGS

- The major use of energy in a building includes lighting, heating, cooling, ventilation, etc.
- Energy is also consumed for the production of materials used to construct the building which is known as embodied energy and also the energy required to transport the construction materials from where they are produced to where they are used.
- With the increase in the global concern for energy and environmental issues, the building sector holds a tremendous potential for energy savings.
- Hence, energy conservation in buildings is the decrease in the use of energy for its construction, for its running and maintenance, by proper design and orientation, use of climatic conditions including passive and active features, use of more efficient equipment's, inclusion of renewable and optimization of thermal comfort condition.

**What is green building.**

- **Green building (also known as green construction or sustainable building)** refers to both a structure and the application of processes that are environmentally responsible and resource-efficient throughout a building's life-cycle: from planning to design, construction, operation, maintenance, renovation, and demolition.

**Objective**

- Green building is designed to reduce the overall impact of the built environment on human health and the natural environment.
- Efficiently using energy, water and other resources.
- Protecting occupant health and improving employee productivity.
- Reducing waste, pollution and environment degradation

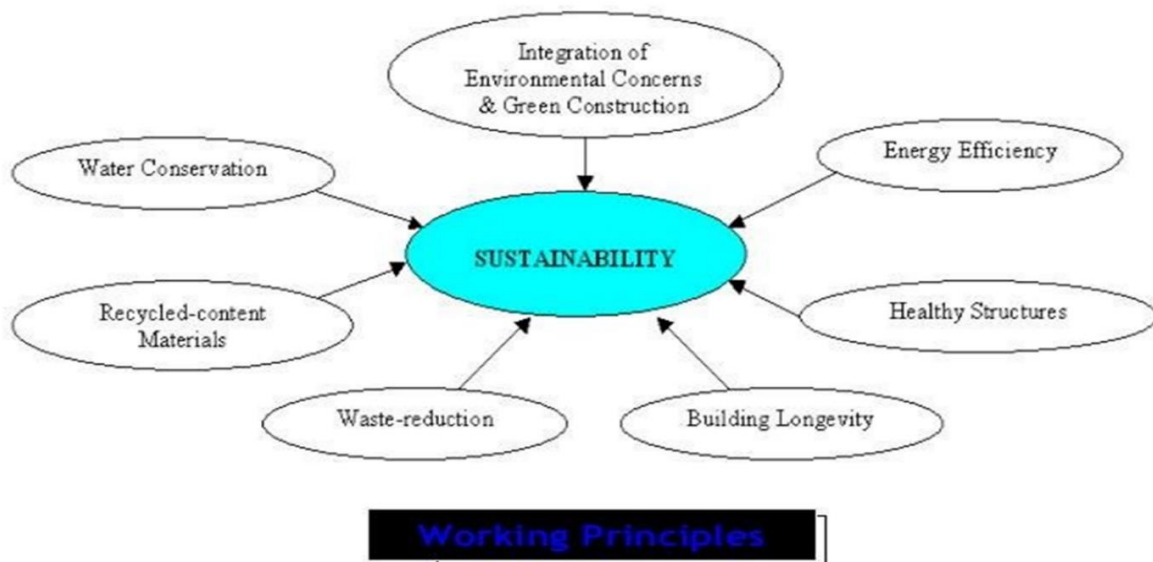

**Goals of Green Building**

- Structure design efficiency
- Energy efficiency

## ENERGY CONSERVATION AND MANAGEMENT

- Water efficiency
- Materials efficiency
- Operations and maintenance optimization
- Waste reduction



## STRUCTURE AND DESIGN EFFICIENCY

- The foundation of any construction project is rooted in the concept and design stages.
- In designing environmentally optimal buildings, the objective is to minimize the total environmental impact associated with all life cycle stages of the building project.

### Energy Efficiency

- Green buildings often include measures to reduce energy use.
- By using high- efficiency windows and insulation in walls, .. ceilings, and floor.
- By using Solar water heating further reduces energy loads
- To minimize water consumption, one should aim to use the water which has been collected, used, purified and reused.

### Operations and maintenance optimization

- No matter how sustainable a building may have been in its design and construction, it can only remain so if it is operated responsibly and maintained properly.
- It is easy to maintenance

## WASTEREDUCTION

- Green architecture also seeks to reduce waste of energy, water and materials used during construction.
- For example, in California nearly 60% of the state's waste comes from commercial buildings.



**WASTE HEAT**

- Waste heat is the energy that is not put into use and is lost into the environment.
- Recovering waste heat can be conducted through various heat recovery technologies.
- Heat recovery provides valuable energy sources and reduces energy consumption

**SOURCES OF WAST WATER**

- Heat loss transferred through conduction, convection and radiation from industrial products, equipment and processes
- Heat discharged from combustion processes

**Benefits of WHR**

- Direct benefits
- Indirect benefit

**Direct benefits:** Reduction in utility consumption and costs and process costs

**Indirect benefit:**

- Reduction in pollution
- Reduction in equipment sizes
- Reduction in auxiliary energy consumption

**Waste Heat Recovery Systems**

- Methods include capturing and transferring the waste heat from a process with a gas or liquid back to the system as an extra energy source
- The energy can be used to create additional heat or to generate electrical and mechanical power
- Regenerative and Recuperative burners
- Economisers
- Air preheaters
- Waste heat boiler
- Plate heat exchangers
- Heat pipe systems
- Heat pumps
- Thermocompression

**Regenerative and Recuperative**

**Burners**

- Optimize energy efficiency by incorporating heat exchanger surfaces to capture and use the waste heat from hot flue gases from combustion process



## ENERGY CONSERVATION AND MANAGEMENT

### Economisers

- Finned tube heat exchangers that recover low-medium waste heat
- Mainly used for heating liquids
- System consists of tubes that is covered by metallic fins to maximize the surface area of heat absorption and heat transfer rate

### WASTED HEAT BOILER

- Consists of several water tubes that are placed in parallel to each other
- Suitable to recover heat from medium- high temperature exhaust gases
- Used to generate steam as an output

### Heat pipe

- Comprises of a sealed container, a capillary wick structure and a working fluid
- Thermal energy absorbing and transferring system

### Heat pump

- Works on the principle of vapour compression cycle
- Applications- Product drying, maintaining dry atmosphere for storage, Drying compressed air

### Plate heat exchangers

- Used to transfer heat from one fluid to another when cross contamination needs to be avoided
- Made out of several thin metal plates that are stacked or brazed in parallel to each other
- Used in pasteurizers

### Thermocompression

- Simple equipment with a nozzle where high pressure steam is accelerated into high velocity fluid
- Typically used in evaporators

### Air Preheaters

- Mainly used for exhaust-to-air heat recovery
- Applications- Heat recovery from furnaces, ovens and steam boilers

### Thermal Energy Storage

- Thermal energy storage (TES), a technology that stocks thermal energy by heating or cooling a storage medium, so that the stored energy can be used later, either for heating and cooling applications or for power generation.
- Also known as heat or cold storage

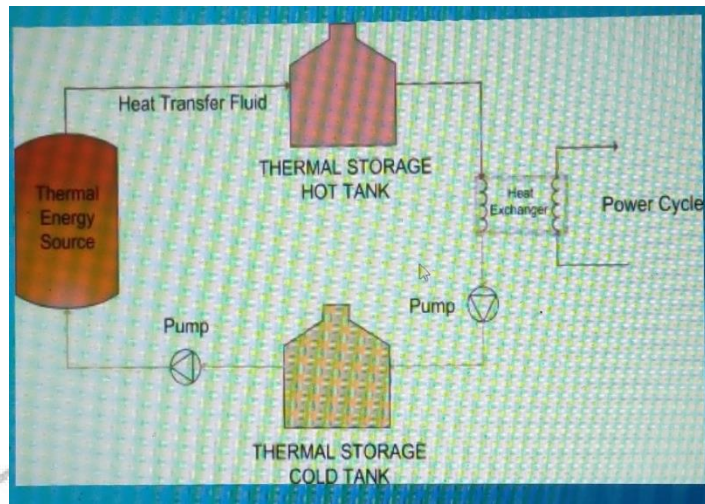

### Applications in Food Processing Industry

- Waste heat recovery in canning facilities can be performed economically using systems that employ thermal energy storage (TES).
- Process cooling
- Food preservation

### CONDENSATE RECOVERY AND REUSE

#### Condensate

- Condensate is the liquid formed when steam passes from the vapour to the liquid state.
- In a heating process, condensate is the result of steam transferring a portion of its heat energy, known as latent heat, to the product, line, or equipment being heated.

#### Condensate recovery

- Condensate recovery is a process to reuse the water and sensible heat contained in the discharged condensate.
- Recovering condensate instead of throwing it away can lead to significant savings of energy, chemical treatment and make-up water.

#### reuses of condensate

- Condensate can be reused in many different ways, for example: As heated feed water, by sending hot condensate back to the boiler's deaerator
- As pre-heat, for any applicable heating system
- As steam, by reusing flash steam
- As hot water, for cleaning equipment or other cleaning applications

#### Benefits of condensate recovery

Reducing boiler fuel needs through condensate recovery leads to less air pollution by lowering CO<sub>2</sub>, NO<sub>x</sub> and Sox emissions.

- Reusing hot condensate can lead to considerable savings in terms of energy and water resources, as well as improve working conditions and reduce your plant's carbon footprint
- When efficiently recovered and reused, it can even be possible to reduce boiler fuel needs by up to 10 to 20%.
- Any impurities picked up during condensate transport are removed, condensate can be reused as boiler feed water, reducing water supply and treatment costs, as well as costs

## ENERGY CONSERVATION AND MANAGEMENT

associated with cold water used to lower condensate temperatures before sewerage, where applicable.

- Additionally, condensate recovery lines can also limit vapour clouds to reduce noise generated from atmospheric condensate discharge and help prevent build-up of water on the ground, considerably improving a plant's work environment.
- Depending on the amount of condensate being recovered and reused, other benefits may include a reduced need for boiler blowdown through better feed water quality, and less corrosion in the system as water quality becomes more consistent throughout the grid.

## Methods

### METHOD – 1: RETURNING CONDENSATE USING TRAP PRESSURE

- Inlet pressure of the steam trap can be used as the driving force for transportation of condensate to the collection tank at positive differential pressure.
- This recovery method is most reliable and cost effective. It is relatively easy to implement as there is no special equipment required for the same.
- There are two different types of installations where recovery can be done by using trap inlet pressure

#### a. By gravity

- As the differential pressure is always positive from downward drainage by gravity to an atmospheric system or vessel, the basic equipment required is steam trap and transport piping.

#### b. Elevated return

- If the differential pressure remains positive and appropriate safety standards are followed, the steam trap can discharge overhead to an elevated return.
- A typical example is the draining of condensate from steam traps installed on main utility steam lines.
- The system back pressure increases with the increase in vertical and horizontal distance. The simple trap option will fail if the differential pressure becomes negative.

### DISADVANTAGES OF THE ABOVE SYSTEM

- Higher backpressure reduces capacity.
- Open bypass valve to avoid condensate flooding inside the equipment.
- Live steam leakage through the bypass.
- Higher steam consumption in the process.
- Especially detrimental where steam traps are operating at different inlet pressures.
- The entire system gets pressurized and stops functioning, even if one steam trap fails

### METHOD – 2: USING ELECTRIC PUMP

- A common centrifugal or turbine condensate pump can be used to increase delivery pressure and obtain positive differential pressure when the pressure differential from source to destination is negative.
- Pumping can make the transport and recovery of condensate over much longer and higher distances possible.
- Condensate is first collected in a tank, and then electrically pumped to the location(s) where it is to be reused.

### DISADVANTAGE OF THE ABOVE SYSTEM

- Back pressure on steam traps
- Flash steam is vented
- Drop in condensate temperature due to radiation loss - across the collection tank



### ENERGY CONSERVATION AND MANAGEMENT

- Too many components to maintain
- Dry running / cavitation of electric pumps o high water treatment cost
- Low feed water temperature
- Use of electricity – the costliest utility

### METHOD – 3: USING STEAM / AIR OPERATED PUMPS

- There is no danger of cavitation as the mechanical condensate pumps rely on positive displacement for pumping and do not use impeller rotation.
- They are relatively unaffected by broad differences in back pressure and are not as critical in their sizing.
- Additionally, they are well-suited for explosion proof areas and remote locations because they do not require any electricity.
- The types and capacities of mechanical pumps have increased in recent years, making them one of the most commonly preferred methods for recovering condensate

### ADVANTAGES OF ABOVE SYSTEM:

- Condensate pumping temperature is in range of 95°C – 100°C.
- 100% flash steam recovery
- Higher feed water temperature.
- • lesser requirement of makeup water
- Low chemical treatment costs • increased S: F
- Consumes only 3 kgs of steam per ton of condensate.
- Deaerator – ensures proper mixing of condensate, flash steam & makeup water.
- Reduced boiler blowdown

**Lesson 11**

**CLEANER ENERGY SOURCES: INTRODUCTION TO SOLAR AND BIOMASS ENERGY**

**TYPES OF ENERGY**

Energy can be broadly classified into:

- Clean energy or Renewable energy
- Dirty energy or Non- renewable energy

**CLEAN ENERGY**

- Clean energy, often referred to as renewable energy
- Comes from natural sources or processes that are constantly replenished
- For example, sunlight or wind keep shining and blowing, even if their availability depends on time and weather.

The most popular renewable energy sources currently are:

1. Solar energy
2. Wind energy
3. Hydro energy
4. Tidal energy
5. Geothermal energy
6. Biomass energy

**. 1) SOLAR ENERGY**

- Solar energy is the energy obtained by capturing heat and light from the Sun.
  - Energy from the Sun is referred to as solar energy.
  - It is considered a green technology because it does not emit greenhouse gases.
  - Solar energy is abundantly available and has been utilized since long both as electricity and as a source of heat
- Sunlight is one of our planet's most abundant and freely available energy resources
  - The amount of solar energy that reaches the earth's surface in one hour are more than the planet's total energy requirements for a whole year
  - Although it sounds like a perfect renewable energy source, the amount of solar energy we can use varies according to the time of day and the season of the year as well as geographical location.

**2.WIND ENERGY**

- Wind is a plentiful source of clean energy
- To harness electricity from wind energy, turbines are used to drive generators which then feed electricity into the National Grid

**3)HYDRO ENERGY**

- By building a dam or barrier, a large reservoir can be used to create a controlled flow of water that will drive a turbine, generating electricity

## **ENERGY CONSERVATION AND MANAGEMENT**

- This energy source can often be more reliable than solar or wind power and also allows electricity to be stored for use when demand reaches a peak
- Like wind energy, in certain situations hydro can be more viable as a commercial energy source but depending very much on the type of property, it can be used for domestic, 'off-grid' generation

### **4) TIDAL ENERGY**

- This is another form of hydro energy that uses twice-daily tidal currents to drive turbine generators
- Although tidal flow unlike some other hydro energy sources isn't constant, it is highly predictable and can therefore compensate for the periods when the tide current is low

### **5) GEOTHERMAL ENERGY**

- By harnessing the natural heat below the earth's surface, geothermal energy can be used to heat homes directly or to generate electricity
- Although it harnesses a power directly below our feet, geothermal energy is of negligible importance in the UK compared to countries such as Iceland, where geothermal heat is much more freely available.

### **6) BIOMASS ENERGY**

- This is the conversion of solid fuel made from plant materials into electricity
- Although fundamentally, biomass involves burning organic materials to produce electricity, and nowadays this is a much cleaner, more energy-efficient process
- By converting agricultural, industrial and domestic waste into solid, liquid and gas fuel, biomass generates power at a much lower economic and environmental cost.

## **THE FUTURE OF RENEWABLE ENERGY**

- As world population rises, so does the demand for energy in order to power our homes, businesses and communities
- Innovation and expansion of renewable sources of energy is key to maintaining a sustainable level of energy and protect our planet from climate change
- Renewable energy sources make up 26% of the world's electricity today, but according to the International Energy Agency (IEA) its share is expected to reach 30% by 2024

## **ADVANTAGES OF SOLAR ENERGY**

- Solar energy is a clean and renewable energy source.
- Once a solar panel is installed, solar energy can be produced free of charge.
- Solar energy will last forever whereas it is estimated that the world's oil reserves will last for 30 to 40 years.
- Solar energy causes no pollution.
- Solar cells make absolutely no noise at all. On the other hand, the giant machines utilized for pumping oil are extremely noisy and therefore very impractical.
- Very little maintenance is needed to keep solar cells running.
- There are no moving parts in a solar cell which makes it impossible to really damage them.

## **DISADVANTAGES**

- Solar panels can be expensive to install resulting in a time-lag of many years for savings on energy bills to match initial investments.
- Electricity generation depends entirely on a country's exposure to sunlight; this could be limited by a country's climate.
- Solar power stations do not match the power output of similar sized conventional power stations; they can also be very expensive to build.



## ENERGY CONSERVATION AND MANAGEMENT

- Solar power is used to charge batteries so that solar powered devices can be used at night. The batteries can often be large and heavy, taking up space and needing to be replaced from time to time.

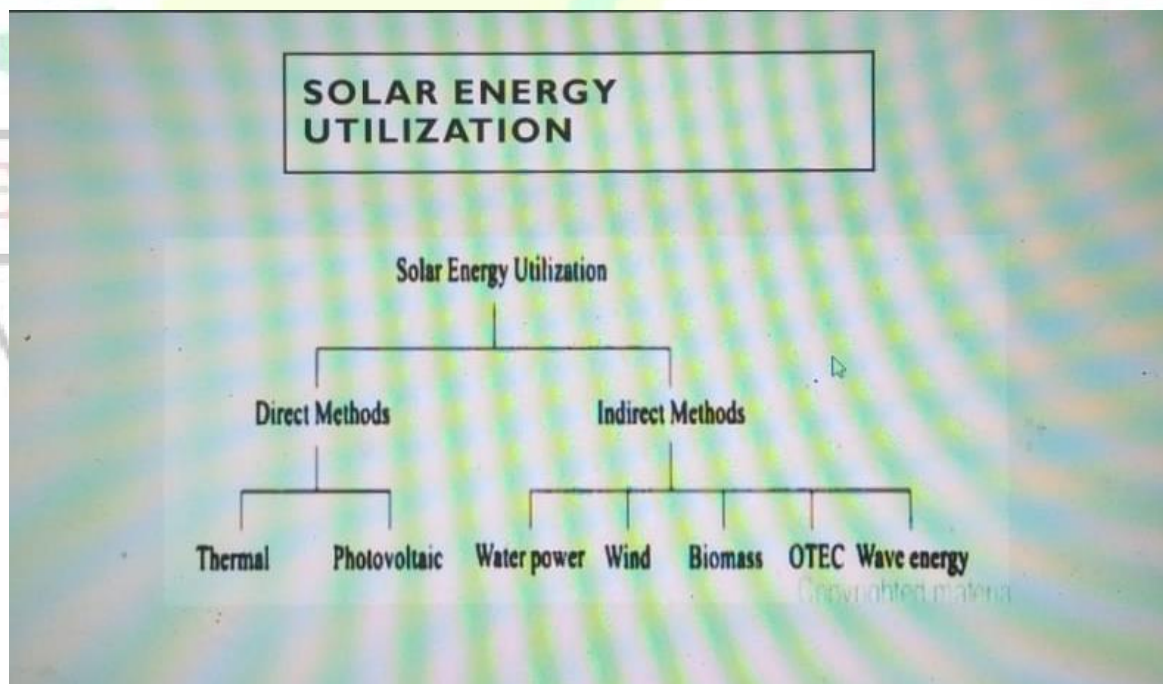
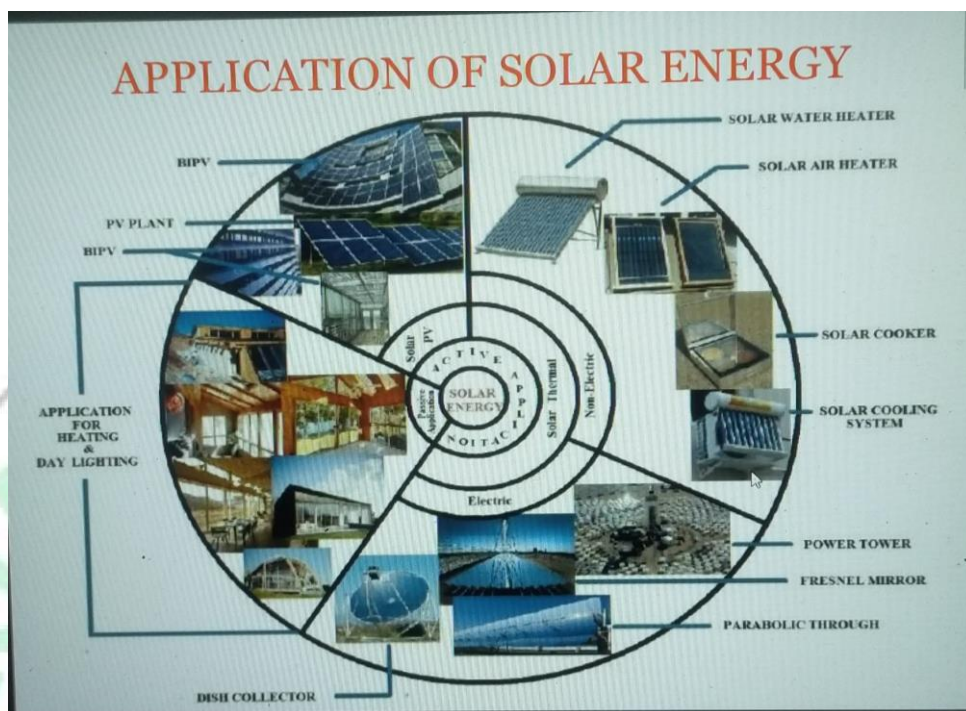

### Solar Thermal Energy

Solar collectors are the main component of most of solar energy systems. The collector absorbs the sun's energy and converts it into heat energy. This energy is then transferred to a fluid or air which is used to heat water, generate electricity, dry materials, distil water or cook food. When used for heating purpose, solar thermal system can partially or fully replace the conventional fuels such as coal, oil and electricity.

**Various applications of solar thermal energy discussed are**

- **Solar Water Heating System** (Flat-plate collector & Evacuated tube collector)

- **Solar Thermal Power Systems** (Power tower, parabolic trough collector)

**Solar Water Heating System**

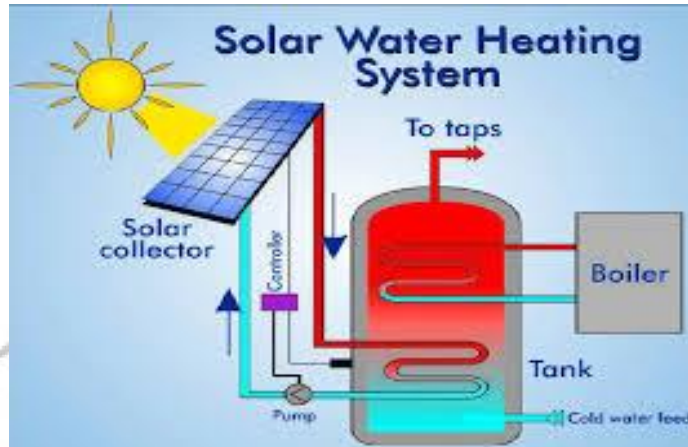

A solar water heating system consists of a flat plate or evacuated tube solar collector, a storage tank and connecting pipes. The system is generally installed on the roof or on open ground, with the collector facing the sun and connected to a continuous water supply. The collectors are generally mounted on a north-facing roof (in southern hemisphere). Water stored in the tank remains hot overnight as the storage tank is insulated and heat losses are small.

**Solar Flat Plate Collector**

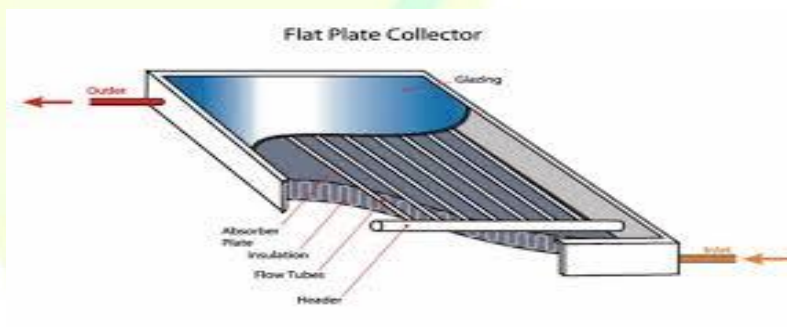

The most common collector is called a flat-plate collector. Flat-plate collectors heat the circulating fluid to a temperature of about 40-60°C. Flat plate collector is highly dependent upon ambient temperatures. It has good efficiency if ambient temperature is high. Consequently, heat output is higher during summer months than winter months in a flat plate collector.

The flat plate collector usually comprises of copper tubes welded to copper sheets (both coated with a highly absorbing black coatings) with toughened glass sheet on top for cover and insulating material at the bottom.

**Evacuated Tube Collector**





## ENERGY CONSERVATION AND MANAGEMENT

For higher temperatures, evacuated tube collectors are used. Evacuated tube collector is less dependent upon ambient temperature unlike flat plate collector and its efficiency does not drop with ambient temperature.

In this type of solar collector, evacuated glass tubes are used instead of copper in which case a separate cover sheet and insulating box are not required. Water flows through the tubes, absorbs solar heat and is stored in a tank. This type of solar collector can reach high temperatures up to 150°C. Evacuated tube collector is shown in Figure

### Solar Electrical Energy

There are broadly two ways of generating electrical energy from solar power, the thermal route and direct conversion route through photovoltaic. There are two basic types of solar thermal power stations: power tower and parabolic trough collector.

#### Power Towers

A typical power tower (see Figure) operation is described as follows:

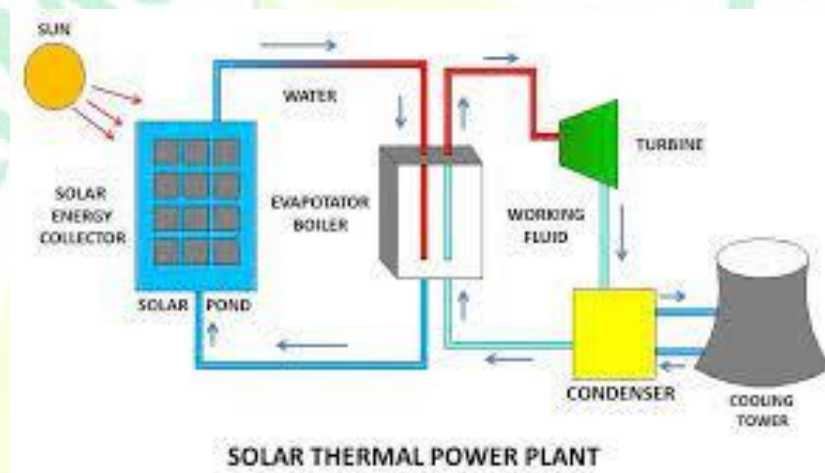

1. Sunlight is concentrated and directed from a large field of heliostats (mirrors) to a receiver on a tall tower.
2. Molten salt (for example liquid sodium) from the cold salt tank is pumped through the central receiver where it is heated to 566°C).
3. The heated salt from the receiver is stored in the hot salt thermal storage tank.
4. Molten salt is pumped from the hot salt tank through a steam generator that creates steam, which drives a steam turbine, generating electricity
5. Cold salt at 288°C flows back to cold salt thermal storage tank and re-used

### BIOMASS ENERGY

- Biomass means living organisms and those that recently died.
- In energy generation, it refers to waste plants that are utilized to generate energy by combustion.
- The methods of conversion to bio-fuel are numerous and largely classified as chemical, thermal and biochemical.
- This is the oldest as well as the most widely spread source of renewable energy.
- Direct combustion was traditionally practiced using wood fuel.
- Advanced processes such as pyrolysis, fermentation and anaerobic digestion converts these sources to a denser and easy to transport forms such as oil and ethanol.
- Biomass energy is energy generated or produced by living or once-living organisms.
- The most common biomass materials used for energy are plants, such as corn and soy.



## ENERGY CONSERVATION AND MANAGEMENT

- The energy from these organisms can be burned to create heat or converted into electricity
- People have used biomass energy—energy from living things—since the earliest “cave men” first made wood fires for cooking or keeping warm.
- Biomass is organic, meaning it is made of material that comes from living organisms, such as plants and animals
- The most common biomass materials used for energy are plants, wood, and waste. These are called biomass feed stocks.
- Biomass contains energy first derived from the sun: Plants absorb the sun’s energy through photosynthesis, and convert carbon dioxide and water into nutrients (carbohydrates).
- The energy from these organisms can be transformed into usable energy through direct and indirect means
- Biomass can be burned to create heat (direct), converted into electricity (direct), or processed into biofuel (indirect).



## ADVANTAGES OF BIOMASS ENERGY

- Abundant and Renewable
- Reduction in deforestation
- Reduction in indoor air pollution and hence smoke related diseases
- Reduce Landfills
- Improvement in soil fertility because of the use of slurry from biogas plant as fertilizer.
- Reduction in green gas emissions.
- Contribution to local economy, through better utilization of local resources.

## DISADVANTAGES OF BIOMASS ENERGY

- Expensive: Living things are expensive to care for, feed and house and all of that has to be considered when trying to use waste products from animals for fuel.
- Harmful to the Environment: Making biomass energy increase methane gases, which are harmful to the Earth’s ozone layer.
- Require more land.
- **The different methods used to generate energy from biomass are:**

### 1. Direct Combustion of Biomass

Biomass energy used to generate heat and electricity through direct combustion in modern devices, ranging from very small-scale domestic boiler to multi megawatt Laze power plant electricity.

Direct combustion is the combustion of biomass in a grate, stoked or fluidized bed with excess air followed by capturing the release of energy, which can then be used to provide steam or hot water for process heating and/or for providing electricity. Solid biomasses include coconut shells, rice husks, bagasse, wood waste, oil seed cakes such as de-oiled

## ENERGY CONSERVATION AND MANAGEMENT

bran (DOB) etc. Biomasses of low bulk density are processed into pellets or briquettes. A typical pelleted fuel is shown in Figure

### 2. Gasification of Biomass

Biomass contains carbon, hydrogen and oxygen molecules. Complete combustion would produce carbon dioxide ( $\text{CO}_2$ ) and water vapour ( $\text{H}_2\text{O}$ ) whereas combustion under controlled conditions i.e. partial combustion produces carbon monoxide ( $\text{CO}$ ) and hydrogen ( $\text{H}_2$ ), which are combustible gases. The biogas produced through gasification is called as producer gas. The producer gas has relatively low calorific value, ranging from 1000 to 1200 kcal/ $\text{Nm}^3$ . The conversion efficiency of the gasification process is the range of 60-70%. It can be used for combustion in a reciprocating engine. When gas is used in dual fuel DG set, it can result in 65-85% diesel savings.

### 3. Bio methanation of Biomass (Anaerobic Process)

Biomass can also be converted into bio-methane gas which is composed mainly of methane and carbon dioxide. The process is based on biological digestion/ anaerobic digestion (bio methanation) of biomass. This is the only process giving additional advantage of high-grade manure as the by-product. The raw materials for bio methanation process include manure, sewage sludge, municipal solid waste, fruit and vegetable waste, food waste, distillery wastes and other biodegradable wastes. Bio-methane can completely replace natural gas for applications using natural gas such as boilers, furnaces, IC engines etc.

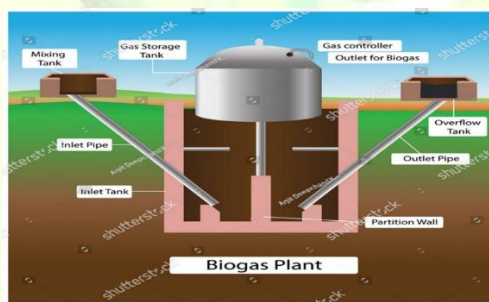

### SOLAR TH4. Biofuels from Biomass

Biomass can be converted into liquid fuels such as Ethanol and Biodiesel to partially replace the conventional petroleum fuels.

Ethanol is commonly produced by the fermentation of molasses, a by-product in sugar manufacture.

It is also produced by fermenting any biomass feedstock rich in carbohydrates (starch, sugar or cellulose). e.g.: Sugar beet, Sweet com and Lingo-cellulosic materials (straw and wood waste), which are much cheaper than molasses, are now being considered for manufacturing ethanol. Ethanol is used as a fuel additive to cut down vehicle's carbon monoxide and other smog causing emissions. Flexible fuel vehicles, which run on mixture of gasoline, use up to 85% ethanol.

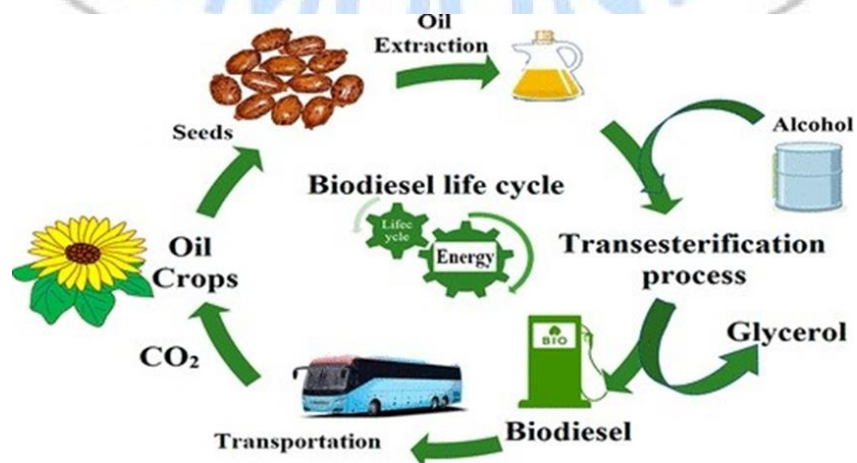



## **ENERGY CONSERVATION AND MANAGEMENT**

### **THERMAL CONVERSION**

- Biomass can be burned by thermal conversion and used for energy
- Thermal conversion involves heating the biomass feedstock in order to burn, dehydrate, or stabilize it
- The most familiar biomass feed stocks for thermal conversion are raw materials such as municipal solid waste (MSW) and scraps from paper or lumber mills.

### **BIOFUEL**

- Biomass is the only renewable energy source that can be converted into liquid biofuels such as ethanol and biodiesel
- Biofuel is used to power vehicles, and is being produced by gasification in countries such as Sweden, Austria, and the United States.
- Ethanol is made by fermenting biomass that is high in carbohydrates, such as sugar cane, wheat, or corn
- Biodiesel is made from combining ethanol with animal fat, recycled cooking fat, or vegetable oil

### **BIOCHAR**

- Biochar, produced during pyrolysis, is valuable in agricultural and environmental use.
- When biomass rots or burns (naturally or by human activity), it releases high amounts of methane and carbon dioxide into the atmosphere
- However, when biomass is charred, it sequesters, or stores, its carbon content
- When biochar is added back to the soil, it can continue to absorb carbon and form large underground stores of sequestered carbon—carbon sinks—that can lead to negative carbon emissions and healthier soil.
- Biochar also helps enrich the soil. It is porous. When added back to the soil, biochar absorbs and retains water and nutrients.

### **HYDROGEN FUEL CELLS**

- Biomass is rich in hydrogen, which can be chemically extracted and used to generate power and to fuel vehicles
- Stationary fuel cells are used to generate electricity in remote locations, such as spacecraft and wilderness areas
- Yosemite National Park in the U.S. state of California, for example, uses hydrogen fuel cells to provide electricity and hot water to its administration building

## **TERMAL AND PHOTO-VOLTAIC ENERGY OPTIONS FOR FOOD PROCESSING INDUSTRIES**

### **SOLAR ENERGY IN FOOD INDUSTRY**

- Application of solar energy in food processing industry was mainly limited to drying operations.
- Solar vegetable-fruit dryers, operating below 55 degree centigrade, are used for the purpose.
- But in recent years, many solar technologies have been developed for variety of applications.
- Different solar concentrators can provide excellent boiling, steaming, blanching and roasting capabilities while Solar Air Dryers/ Heaters can effectively remove moisture.
- There is a vast potential for use of solar energy devices / systems in industries for process heat and other thermal applications.



## ENERGY CONSERVATION AND MANAGEMENT

- Energy for these applications were being met mainly through fuel oil which is not only import dependent but is also creating huge GHG emissions in atmosphere resulting threat to our planet.
- Solar food processing is an emerging technology that provides good quality foods at low or no additional fuel costs.
- A number of solar dryers, collectors and concentrators are currently being used for various steps in food processing and value addition.
- With the help of concentrators, higher temperatures can be achieved and solar heating systems with concentrators can be effectively used in this particular industry.
- This basic principle is very simple but the development of such systems in India for this particular area of application has so far been overlooked by the solar energy technologists

### **THERMAL ENERGY IN FOOD INDUSTRY**

- The thermal energy generated can be stored to supply energy requirements during evening and night.
- The unit is best suited for the industrial applications using thermal energy from electricity or liquid fossil fuels.
- The thermal medium can be high- or low-pressure process steam, water, air, thermic fluid or oil.
- It can be used for providing process heat for a wide range of applications using boilers or heaters.

### **THERMAL ENERGY EFFICIENCY OPTIONS IN FOOD PROCESSING**

- A. Waste heat recovery
- B. Novel thermodynamics cycles
  - 1) heat pumps
  - 2) novel refrigeration cycles
  - 3) heat pipes
  - 4) hybrid heating systems

### **PHOTOVOLTAIC ENERGY**

- Photovoltaics (PV) is the conversion of light into electricity using semiconducting materials that exhibit the photovoltaic effect, a phenomenon studied in physics, photochemistry, and electrochemistry.
- The photovoltaic effect is commercially utilized for electricity generation and as photosensors.

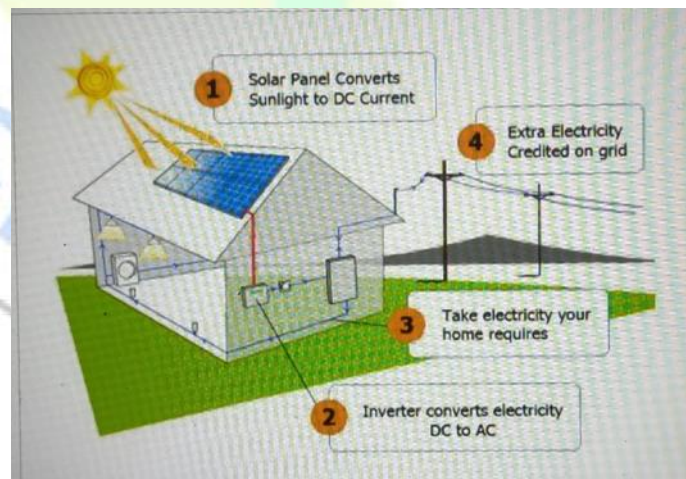

## WIND ENERGY

- Wind is a plentiful source of clean energy
- To harness electricity from wind energy, turbines are used to drive generators which then feed electricity into the National Grid
- Although domestic or 'off-grid' generation systems are available, not every property is suitable for a domestic wind turbine

## ENERGY CONSERVATION AND MANAGEMENT

- The use of wind energy is not new and has been used for thousands of years for applications such as water pumping, milling grains, mechanical power, sailing etc.
- However, it is the use of wind energy for electricity generation that is receiving most attention today.
- Modern windmills are normally called as wind turbines as their functions are similar to gas and steam turbines.
- They are also called as wind energy conversion systems (WECS), and those used to generate electricity are described as wind generators.

### How Wind is Created?

As the earth orbits the sun daily, it receives light and heat. The majority of the heat from the sun is received at the equator and it gradually reduces towards both poles. Across the earth these heat differences help create wind. In warmer regions of the earth the air is hot and is therefore at a high pressure, compared to colder regions, where the air is at a low pressure. Wind is the movement of air from areas of high pressure to low pressure. Ideally, wind should flow from equator to the direction of either pole if earth is not rotating.

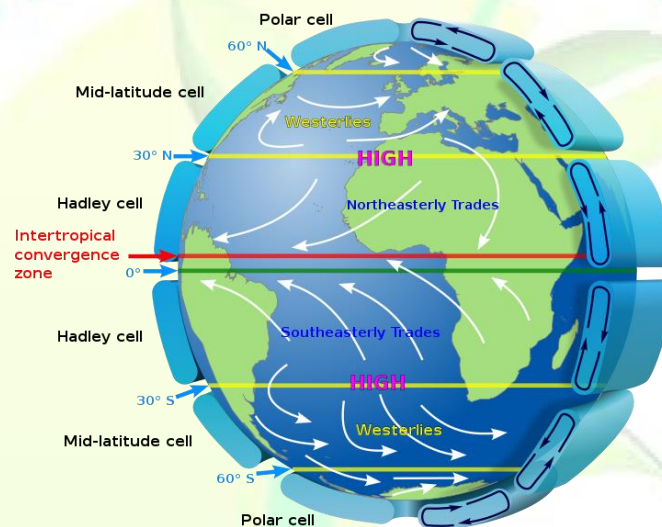

Figure Global Wind Flow

## CARBON CREDITS AND CARBON TRADE

### CARBON CREDIT

- It is a tradable permit or certificate that provides the holder of the credit the right to emit one ton of carbon dioxide or an equivalent of another greenhouse gas.
- The main goal for the creation of carbon credits is the reduction of emissions of carbon dioxide and other greenhouse gases from industrial activities to reduce the effects of global warming.
- For some companies, the immediate reduction of the emission is not economically viable. Therefore, they can purchase carbon credits to comply with the emission cap.
- Companies that achieve the carbon offsets are usually rewarded with additional carbon credits.
- A carbon credit (often called a carbon offset) is a financial instrument or permit representing the right to emit one tonne of CO<sub>2</sub> (carbon dioxide) or CO<sub>2</sub> eg: (carbon dioxide equivalent gases) into the atmosphere
- It represents the amount of GHG s removed or reduced from the atmosphere from an emission reduction project
- This carbon credit can be used by governments, industry or private individuals to offset damaging carbon emissions that they are generating



## ENERGY CONSERVATION AND MANAGEMENT

- Thus, carbon credits are used as a permit to emit certain amount of CO<sub>2</sub> into the atmosphere
- One carbon credit corresponds to one tonne of CO<sub>2</sub>
- Carbon credits are acquired through:

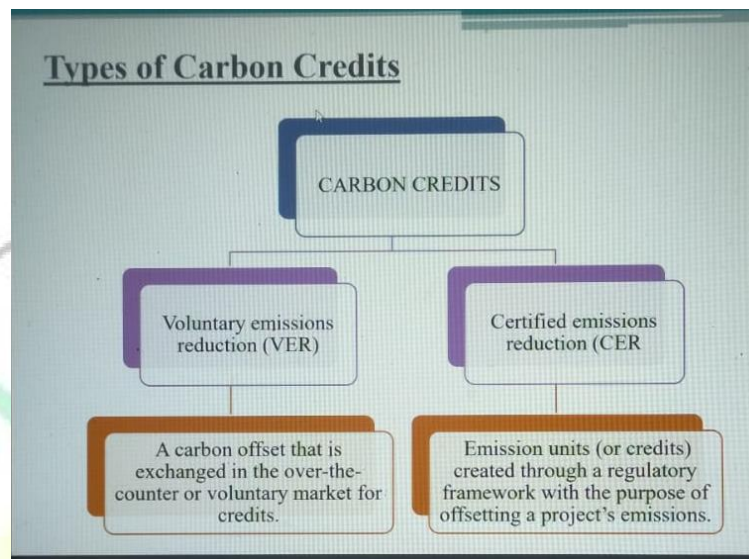

## THE KYOTO PROTOCOL

- A protocol to the United Nations Framework Convention on Climate Change (UNFCCC or FCCC), aimed at fighting global warming.
- Sets binding targets for 37 industrialized countries and the European community to reduce their Greenhouse Gas (GHG) emissions.
- Binding countries to meet their targets primarily through national markets
- Additional means of meeting targets through three market based mechanisms:
- Emissions trading - known as the carbon market Joint implementation (JI) and Clean development mechanism

(CDM)

- First two mechanisms relevant to Annex I / Annex II countries and the third is relevant to developing countries.

### Parties to UNFCCC are classified as:

- Annex I countries - industrialized countries and economies in transition
- Annex II countries - developed countries which pay for costs of developing countries

## CARBON TRADING

- It refers to buying and selling of carbon credits that have been either distributed by a regulatory authority or generated by GHG emissions reduction projects.



## ENERGY CONSERVATION AND MANAGEMENT

- In cap & trade mechanism, a regulatory authority limits (cap) the amount of GHG to be released over a period of time. If organizations have a shortfall or surplus in GHG allowances, they can engage in trade with each other
- . It is the buying and selling of permits to emit carbon dioxide, with the goal of gradually reducing carbon emissions and mitigating its contribution to climate change.
- Carbon trading is generally conducted between nations.
- The European Union Emissions Trading System is the world's largest carbon trade market.
- Carbon trading is also referred to as carbon emissions trading.

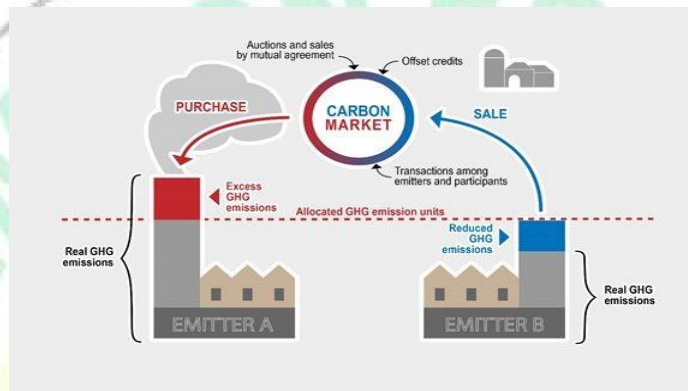

## CLEAN DEVELOPMENT MECHANISM (CDM)

### The Kyoto Mechanism

- Adopted by UNFCCC in Dec 11 1997
- Enforced in 2005
- Joint Implementation (JI)
- International Emission Trading (IET)
- Clean Development Mechanism (CDM)

### The Project Cycle in CDM

1) **Project design:** the first step is the preparation of a project design document by the project participant detailing the project, the baseline and methodology and other details relevant to the project

2) **National Approval:** the second step is securing the letter of approval from the Designated National Entity of the host party;

3) **Validation:** the project is independently evaluated by a

designated operating entity on whether it meets the requirements of CDM.

4) **Registration:** validated projects are submitted to the CDM executive board for formal approval, which is called registration

5) **Monitoring:** Measurement of actual emissions is done by the project participant according to the approved methodology

6) **Verification:** Is the independent review of the emission reductions claimed by the project participant by a designated operating entity

## ENERGY CONSERVATION AND MANAGEMENT

**7) CER issuance:** Once the verification of the claimed emission reduction is done, the designated operating entity submits the verification report to the CDM board for the issuance of CERs

- **What is Clean Development mechanism?**

Article 12

“CDM allows a country with an emission reduction or emission limitation commitment under the Kyoto Protocol to implement an emission reduction project in developing countries”



- Allows emission-reduction projects in developing countries to earn certified emission reduction (CER) credits
- CERs can be traded and sold, and used by industrialized countries to meet a part of their emission reduction targets under the Kyoto Protocol

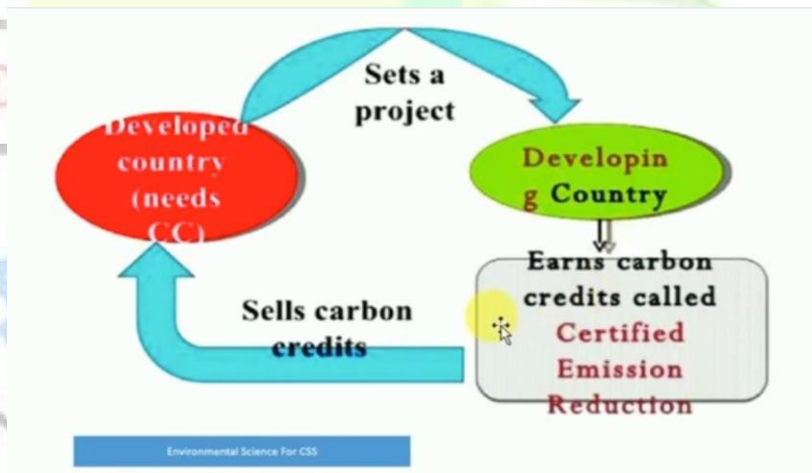

## CDM

### Objectives

- To help developed countries fulfill their commitments to reduce emissions
- To assist developing countries in achieving sustainable development
- Help slow and prevent climate change

### Goals

- Guide developing nations to develop sustainable methods

## ENERGY CONSERVATION AND MANAGEMENT

- Assist the developed nations to reduce their emissions
- Help countries to find new methods to reduce emissions

### Benefits

- Reduction in overall emission mitigation costs
- Flexibility in meeting emission reduction commitments
- Investment Opportunities
- Additional financing for sustainable development projects
- Technology transfer and development
- Mitigates local environment pollution
- Helps to earn tradable, saleable certified emission reduction (CER) credits that can be used by industrialised countries to meet a part of their emission reduction targets under the Kyoto Protocol
- Investment in climate change mitigation projects in developing countries
- Transfer or diffusion of technology in the host countries
- Improvement in the livelihood of communities through the creation of employment or increased economic activity





## Lesson 12

### Fuel & oil conservation

#### What is fuel?

- A substance that produces useful energy when it undergoes some chemical or nuclear reactions
- E.g. Fuel such as wood, coal , oil or gas provides energy when burnt



#### classification

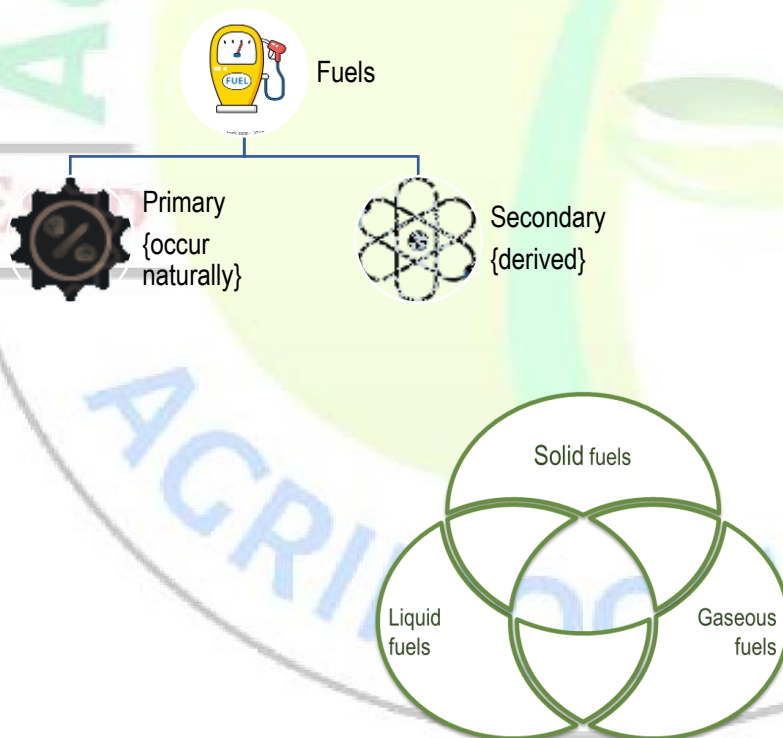

#### Primary fuel

- Occur naturally
- Coal, crude petroleum, natural gas

#### Secondary fuel

- Derived from primary fuel
- Coke, gasoline, coal gas

## ENERGY CONSERVATION AND MANAGEMENT

### FUEL & OIL CONSERVATION

- Use DG set within the rated power
- Two layers of silk cloth can be added to fuel tank filter to increase combustion rate by reducing the impurity
- Necessary to increase the temperature of cooling water during startup of heat engine  
Installing the driving wheel to increase the speed of pump
- Installation of inertial supercharger and fuel –saving smoke reducer to increase the power
- Adding a layer of foam plastic with good air permeability to the filter screen of the air filter improves filtration

### ENERGY SAVING OPPORTUNITIES IN DG SETS

- Ensure steady load conditions on the DG set, and provide cold, dust free air at intake (use of air washers for large sets, in case of dry, hot weather, can be considered).
- Improve air filtration.
- Ensure fuel oil storage, handling and preparation as per manufacturers' guidelines/oil company data.
- Consider fuel oil additives in case they benefit fuel oil properties for DG set usage.
- Calibrate fuel injection pumps frequently.
- Ensure compliance with maintenance checklist.
- Ensure steady load conditions, avoiding fluctuations, imbalance in phases, harmonic loads.
- In case of a base load operation, consider waste heat recovery system adoption for steam generation or refrigeration chiller unit incorporation.
- Even the Jacket Cooling Water is amenable for heat recovery, vapour absorption system adoption.
- In terms of fuel cost economy, consider partial use of biomass gas for generation. Ensure tar removal from the gas for improving availability of the engine in the long run.
- Consider parallel operation among the DG sets for improved loading and fuel economy thereof.
- Carryout regular field trials to monitor DG set performance, and maintenance planning as per requirements

### Maintenance of DG Sets

- **Operating Generator:** If it is manually operated generator, whenever power goes off, before starting the generator, keep the changeover in '0' position. Then manually switch on the generator. Leave the generator for few seconds to withstand the rated voltage. Change over to the generator supply.
- **Generator room:** first Aid box and fire extinguisher and sand container should be available. A safety chart should be displayed. Operator should wear shockproof grousse Periodical earthing /maintenance is required.
- **Automatic Generator:** For automatic generator, it will switch on automatically with the help of contactor. Periodical maintenance is required for contactor and the timer. Fuel level should be maintained.
- **Routine General Inspection:** During the running of the diesel generator, few parts have to be monitored for safety. It includes the exhaust system, fuel system, DC electrical system and engine. Any leaks in fuel tank or pipes, if present, must be fixed immediately to prevent any hazardous occurrences.
- **Lubrication Service;** The engine oil must be checked while shutting down the generator at regular intervals. The oil and filter must also be changed at the recommended time intervals. The disposal is also to be done appropriately so as to prevent any environmental hazards. Periodical B check is to be got done.

## ENERGY CONSERVATION AND MANAGEMENT

- **Cooling System:** The coolant levels must be regularly checked. After shutting down the engine, leave for half an hour. Remove the radiator cap for the engine to cool down. The exterior of the coolant must be inspected for any kind of obstruction, dirt or grime
- **Fuel System:** The fuel in the diesel generator is best used up within a year; before it starts degrading or getting contaminated. The fuel filter is also to be drained at frequent intervals to allow the water vapour and accumulated dust to be drained off from the reservoir.
- **Testing Batteries:** The battery must be kept fully charged and well maintained to avoid deterioration. Regular testing and inspection are essential to know the current status of the battery and avoid any start-up problems of the diesel generator. They must also be cleaned; and the specific gravity and electrolyte levels of the battery checked often. If it is maintenance battery, regular check of the distilled water to be checked.
- **Routine Engine Exercise:** The engine parts may be under intense stress owing to the load. Routine exercise is necessary to keep them lubricated, preventing the oxidation of the electrical parts as well as use of the fuel without letting it deteriorate. On the whole, the engine exercise ensures prompt starting of the engine without any hitches. Proper preventive maintenance tips help to keep the engine working efficiently for longer times and cut down costs on the running or repairs of the equipment. It is thus mandatory to utilize the diesel generator as a reliable standby power supply source. If any additional connections are to be fixed to existing the generator capacity, it should be ensured that the load capacity should not be more than 80% of the generator capacity.

### Fossil fuels

- Fossil fuel is a generic term for non-renewable energy sources such as coal, coal products, natural gas, derived gas, crude oil, petroleum products and non-renewable wastes.
- Formed from organic matter many million years ago



### Alternative fuels

- Any substances that can be used as fuels other than fossil fuels.
- Advanced fuels/ non- convectional fuels
- E.g. biodiesel, bio alcohol, etc.



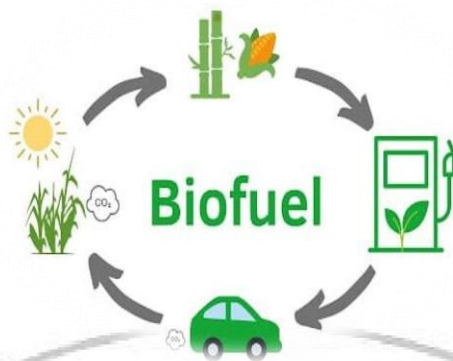

**India total energy consumption**

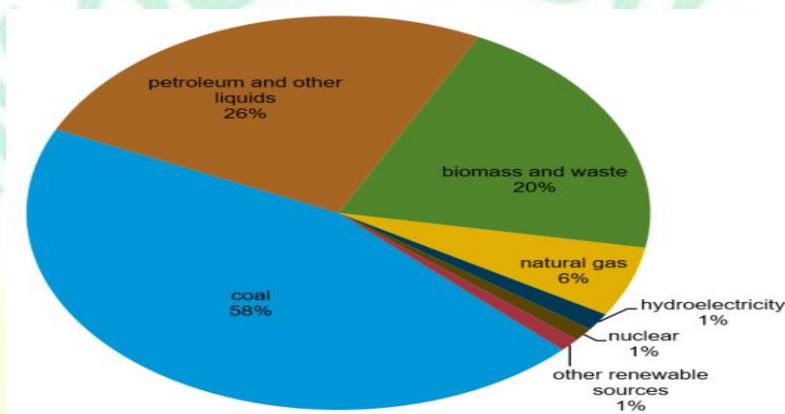

**1. Conservation of fuels in vehicles**

- 2. Turn off vehicle in slow traffic
- 3. Use A/C sparingly
- 4. Use electric powered cars
- 5. Drive less
- 6. Use public transport

**Ways of conservation**

- Use Ac or heaters when required
- Use alternative resources
- Use energy saving bulbs
- Use of biofuels
- Creating awareness about the impacts

**DIESEL GENERATING SETS**

**Diesel Generator**

## ENERGY CONSERVATION AND MANAGEMENT

- DG set is a kind of power generation equipment with diesel fuel as the main fuel, which uses diesel engine as the primary power to drive the generator to generate electricity and convert kinetic energy into electric energy and heat energy.
- Diesel Engine is a **compression ignition engine with diesel fuel**.
- Usually, a diesel generator set is composed of **three parts**: diesel engine, AC synchronous generator and control panel.
  
- The working principle of diesel engine is that the air is compressed in the cylinder which causes the temperature to rise. The diesel oil sprayed into the cylinder self-burns, produce high temperature and high-pressure gas. The fuel gasses expansion forces the piston to work, the heat energy is converted into mechanical energy.
- As a matter of fact, the diesel engine working is done by **four processes**: **intake, compression, combustion expansion, and exhaust, which forms a working cycle.**

### Four process

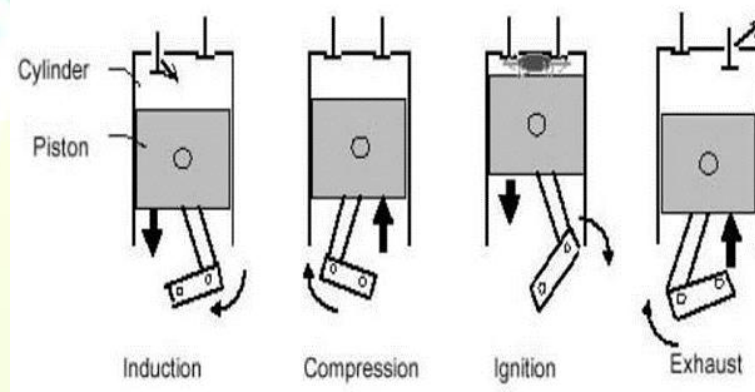

### WORKING

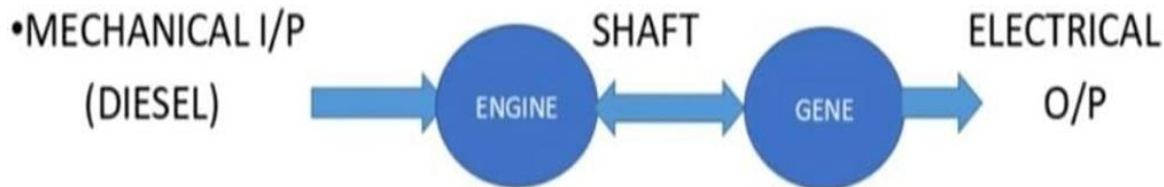

- DG is working in the principle of faradays law of electromagnetic induction. whenever the current carrying conductor placed in the magnetic field that conductor cut the magnetic flux and produced the emf in the conductor.

Activate Windows

### DG set system

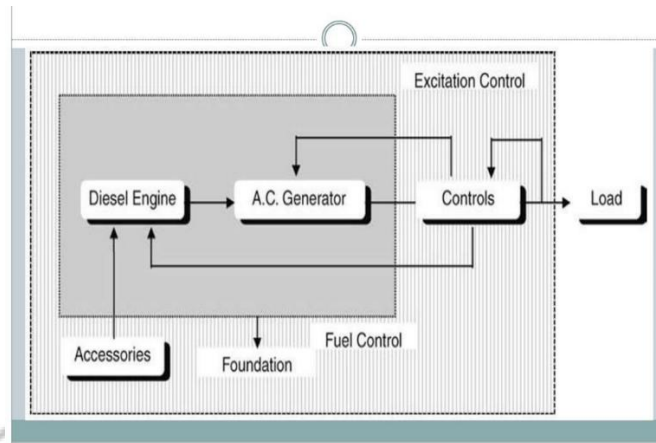

## THERMAL ENERGY STORAGE

### INTRODUCTION

- The thermal energy storage become integral to most renewable energy devices.
- TES systems store thermal energy during off-peak hours when demand is low and release it when needed.
- This can be achieved through various technologies, such as ice storage, phase change materials, and molten salts.
- TES systems offer an eco-friendly alternative by storing excess thermal energy during periods of low demand and utilizing it during the drying process, ensuring a consistent supply of energy without relying on non-renewable sources.
- Thermal energy storage (TES) allows the storage of heat and cold to be used later. TES is also known as heat or cold storage. TES can aid in the efficient use and provision of thermal energy whenever there is a mismatch between energy generation and use.
  - Heating or cooling a medium to use the energy when needed later
  - Thermal energy storage classified into 3
    1. Sensible
    2. Latent
    3. Thermochemical reaction

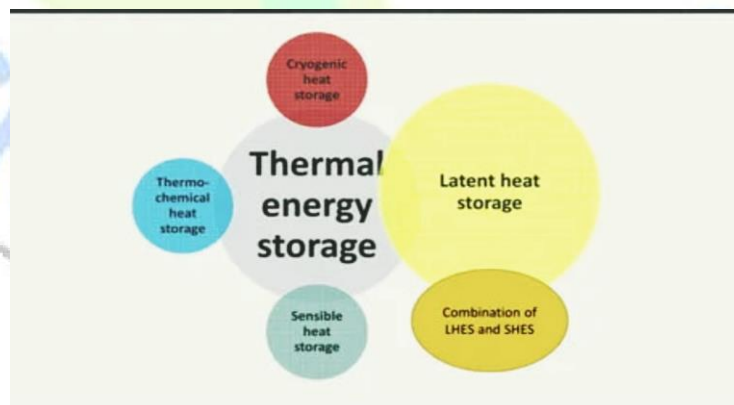

### 1. SENSIBLE THERMAL ENERGY STORAGE

- Use water or rock for storing and releasing heat energy
- Most viable method to reduce energy consumption and CO2 emission
- Amount of energy stored depend upon
- Specific heat of Medium
- Temperature change



## ENERGY CONSERVATION AND MANAGEMENT

- Amount of storage material

$$Q = \int_{T_i}^{T_f} mC_p dT$$
$$= mC_{ap}(T_f - T_i)$$

### 2. Latent heat storage system

- System store energy without changing temperature
- Change in state occur
- Material store heat in their mass as Latent heat – called phase change materials (PCM)
- Most commonly used in food industry

**3. Thermochemical storage** uses reversible chemical reactions and sorption systems.

- The Latent Heat Storage material is preferred when a constant heat supply is required, while Sensible Heat Storage material is preferred for a wide range of temperature application.
- LHS is used where higher energy storage capacity is required, while for the lower energy storage cap, SHS is preferred.

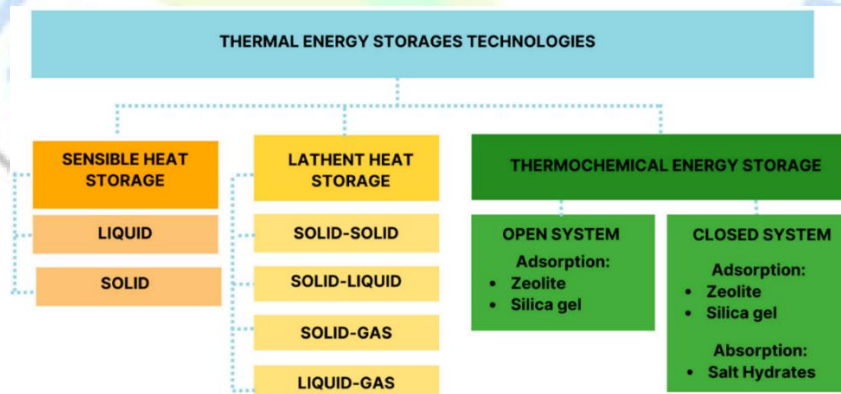

### Applications of thermal energy storage in food facilities

Refrigeration: Storing chilled water for cooling equipment and products.

Cooking: Preheating water for cooking processes, reducing reliance on boilers.

Cleaning: Storing hot water for cleaning and sanitation.

Pasteurization: Preheating water for pasteurization processes.



### Benefits of TES for Food Facilities

- **Cost savings:** By shifting energy use to off-peak hours, TES can significantly reduce energy bills.
- **Reduced carbon footprint:** TES contributes to sustainability by minimizing reliance on peak grid power and integrating renewable energy.: Reduce greenhouse gas emissions and dependence on fossil fuels
- **Enhanced process control:** TES allows for more precise temperature control, leading to better product quality and consistency.
- **Increased equipment lifespan:** Reduced peak demand on equipment extends its lifespan and lowers maintenance costs.
- **Reduced energy consumption:** Generate electricity from waste heat, lowering reliance on grid power.

### CONCLUSION

- WHR and TES offer significant potential for food facilities to reduce their environmental impact and operational costs
- By capturing and storing waste heat, facilities can achieve greater energy efficiency and sustainability
- Investing in WHR and TES technologies can lead to a more competitive and responsible food production industry
- By reducing energy consumption, cutting costs, and minimizing environmental impact, successful integration of TES systems has emerged as a beacon of hope for food processing industry worldwide.

### Commercial Waste Heat Recovery Devices

- a) Recuperators
- b) Regenerators
- c) Economisers
- d) Heat wheels
- e) Passive air preheater
- f) Waste heat boilers

#### RECUPERATORS

- a) Heat exchange takes place between the flue gases and the air through metallic or ceramic walls
- b) Duct or tubes carry the air for combustion to be pre-heated, the other side contains the waste heat stream.
- c) Types of Recuperators are:
  - Metallic
  - Convective

## ENERGY CONSERVATION AND MANAGEMENT

- Radiation
- Ceramic

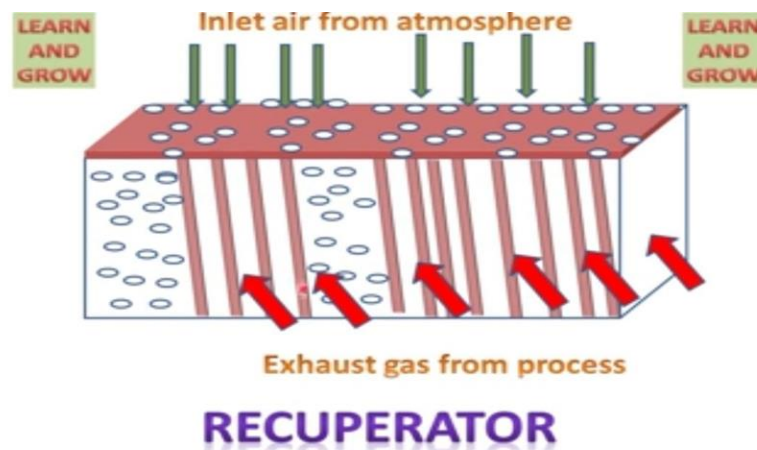

### Metallic Recuperators

- The simplest configuration for a Recuperators, which consists of two concentric lengths of metal tubing.
- The inner tube carries the hot exhaust gases while the external annulus carries the combustion air from the atmosphere to the air inlets of the furnace burners.
- the use of parallel flow is that Recuperators frequently serve the additional function of cooling the duct carrying away the exhaust gases and consequently extending its service life
- The hot gases are cooled by the incoming combustion air which now carries additional energy into the combustion chamber
- The saving in fuel also means a decrease in combustion air and therefore stack losses are decreased not only by lowering the stack gas temperatures but also by discharging smaller quantities of exhaust gas

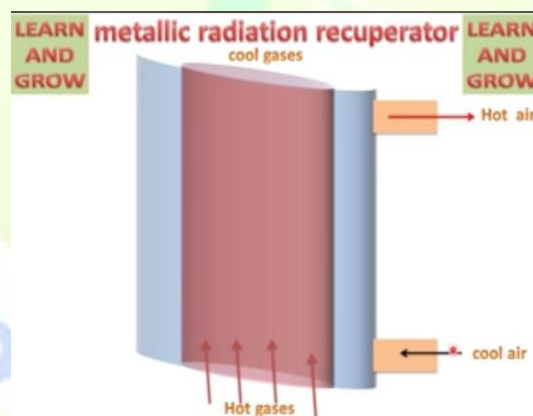

### Convective Recuperators

- The hot gases are carried through a number of parallel small diameter tubes, the incoming air to be heated enters a shell surrounding the tubes and passes over the hot tubes one or more times in a direction normal to their axes.
- If the tubes are baffled to allow the gas to pass over them twice, the heat exchanger is termed a two-pass Recuperators; if two baffles are used, a three-pass Recuperators, etc.
- Although baffling increases both the cost of the exchanger and the pressure drop in the combustion air path, it increases the effectiveness of heat exchange.
- Shell and tube type Recuperators are generally more compact and have a higher effectiveness than radiation Recuperators, because of the larger heat transfer area.



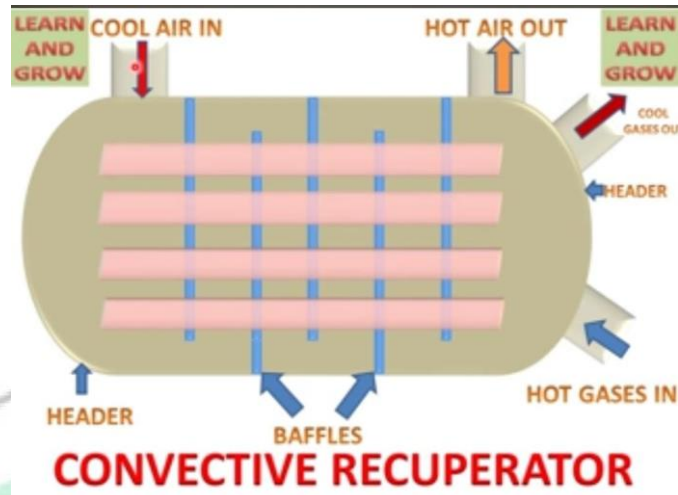

### Radiation/Hybrid Recuperators

- For maximum effectiveness of heat transfer, combinations of radiation and convective designs are used, with the high-temperature radiation Recuperators being first followed by convection type.
- more expensive than simple metallic radiation Recuperators, but are less bulky
- The radiation Recuperators gets its name from the fact that a substantial portion of the heat transfer from the hot gases to the surface of the inner tube takes place by radiative heat transfer.
- The cold air in the annuals, however, is almost transparent to infrared radiation so that only convection heat transfer takes place to the incoming air.

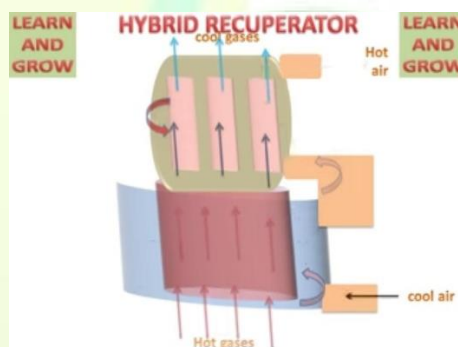

### Ceramic Recuperators

- They are developed whose materials allow operation on the gas side to 1550°C and on the preheated air side to 815°C on a more or less practical basis.
- Early ceramic Recuperators were built of tile and joined with furnace cement, and thermal cycling caused cracking of joints and rapid deterioration of the tubes.
- Later developments introduced various kinds of short silicon carbide tubes which can be joined by flexible seals located in the air headers. Earlier designs had experienced leakage rates from 8 to 60 percent.
- The new designs are reported to last two years with air preheat temperatures as high as 700°C, with much

### REGENERATORS

- Widely used in glass and steel melting furnaces
- The time between the reversals is an important aspect. Long periods would mean higher thermal storage and hence higher cost.

## ENERGY CONSERVATION AND MANAGEMENT

- Accumulation of dust and slagging on the surfaces reduce efficiency of the heat transfer as the furnace becomes old.
- Heat losses from the walls of the regenerator and air in leaks during the gas period and out leaks during air period also reduces the heat transfer

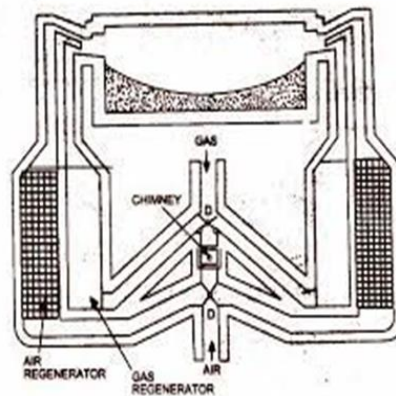

### Heat wheels

- increasing applications in low to medium temperature waste heat recovery systems
- It is a sizable porous disk, fabricated with material having a fairly high heat capacity, which rotates between two side-by-side ducts: one a cold gas duct, the other a hot gas duct
- The axis of the disk is located parallel to, and on the partition between, the two ducts.

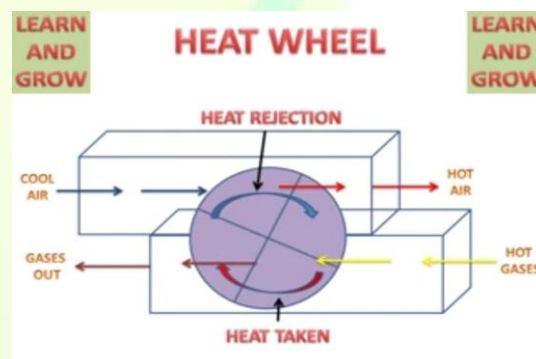

- As the disk slowly rotates, sensible heat (moisture that contains latent heat) is transferred to the disk by the hot air and, as the disk rotates, from the disk to the cold air.
- The overall efficiency of sensible heat transfer for this kind of regenerator can be as high as 85 percent
- A variation of the Heat Wheel is the rotary regenerator where the matrix is in a cylinder rotating across the waste gas and air streams
- An area of application is where heat exchange between large masses of air having small temperature differences is required.

### Heat pipe

- A thermal energy absorbing and transferring system and have no moving parts and hence require minimum maintenance.
- Can transfer up to 100 times more thermal energy than copper
- three elements - a sealed container, a capillary wick structure and a working fluid.
- The heat pipe exchanger (HPHE) is a lightweight compact heat recovery system
- It does not need input power for its operation and is free from cooling water and lubrication systems

## ENERGY CONSERVATION AND MANAGEMENT

- It also lowers the fan horsepower requirement and increases the overall thermal efficiency of the system
- The heat pipe heat recovery systems are capable of operating at 315°C. with 60% to 80% heat recovery capability

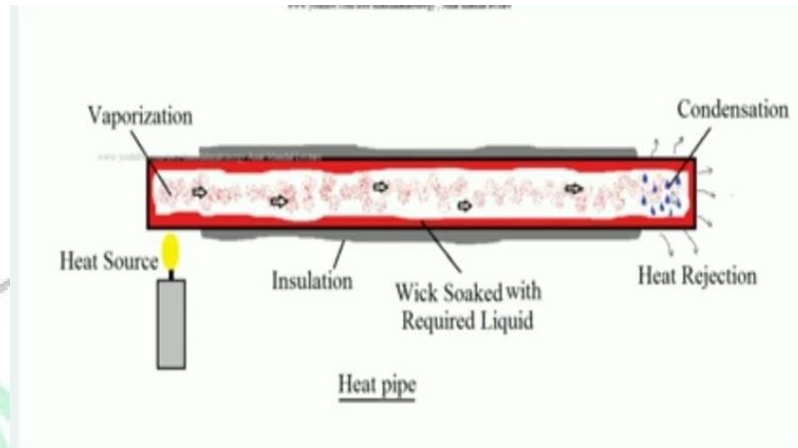

### Waste heat boilers

- Water tube boilers in which the hot exhaust gases from gas turbines, incinerators, etc., pass over a number of parallel tubes containing water
- The water is vaporized in the tubes and collected in a steam drum from which it is drawn off for use as heating or processing steam
- If waste heat in the exhaust gases is insufficient for generating the required amount of process steam, auxiliary burners are added.

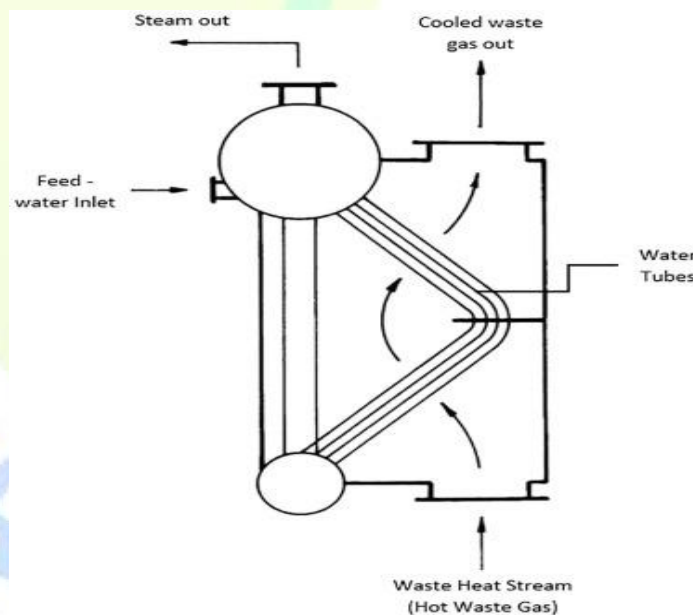

### Work on the principle of the vapour compression cycle

- The circulating substance is physically separated from the source (waste heat) and user (heat to be used in the process) streams, and is re-used in a cyclical fashion, therefore called 'closed cycle'
- The heat pumps have the ability to upgrade heat to a value more than twice that of the energy consumed by the device
- Heat pump applications are most promising when both the heating and cooling capabilities can be used in combination.

## THERMOCOMPRESSOR



**ENERGY CONSERVATION AND MANAGEMENT**

- very low pressure steam are reused as water after condensation for and In many cases it becomes feasible to compress this low pressure steam by very high pressure steam and reuse it as a medium pressure steam
- It is a simple equipment with a nozzle where HP steam is accelerated into a high velocity fluid
- This entrains the LP steam by momentum transfer and then recompresses in a divergent venture
- used in evaporators where the boiling steam is recompressed and used as heating steam

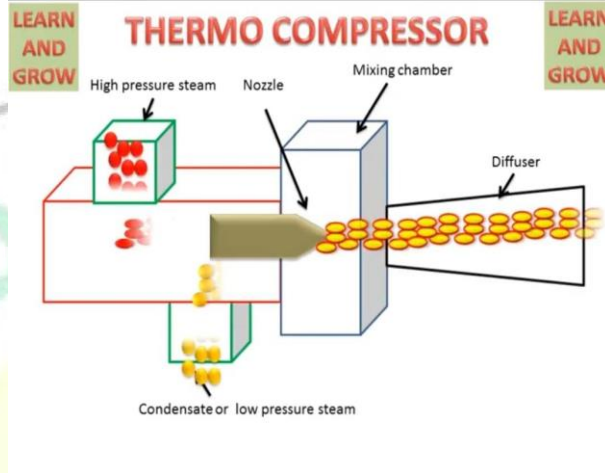

**PCM encapsulation**

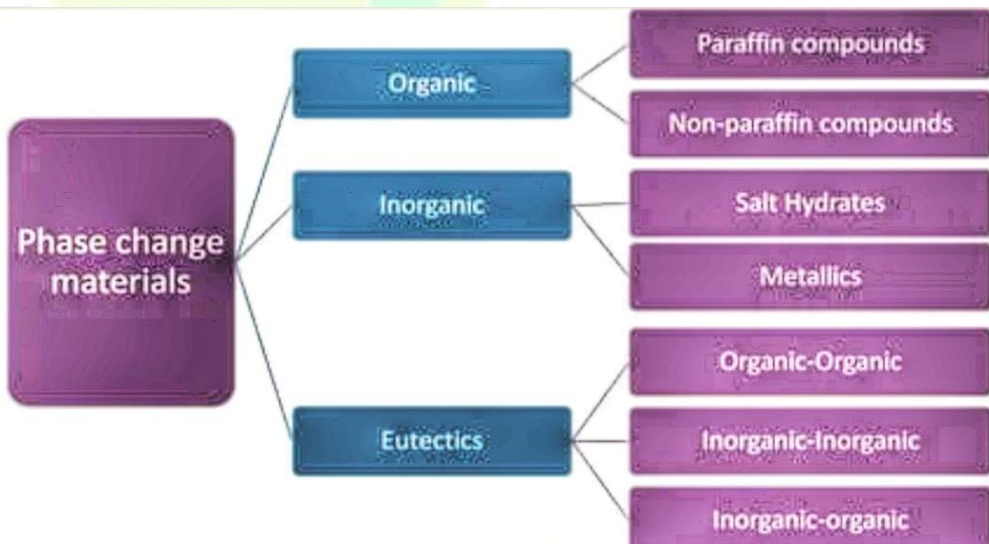
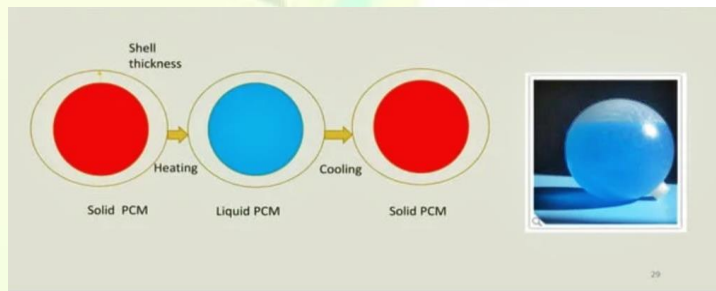

**Selection criteria for pcm**

- Ozone depleting potential
- Fire hazards
- Cost
- Corrosiveness
- Heat transfer characteristics

## ENERGY CONSERVATION AND MANAGEMENT

- Thermal & mechanical stability

### PCM IN TRANSPORTATION –COLD CHAIN

- PCM used to stabilize temperature during transportation
- It improves frozen goods transportation
- It replaces water for stabilizing heat



### MAJOR COMPANIES PROVIDING TES SYSTEMS

- TESSOL
- Cool Electrical
- Cristopia energy
- Clique solar
- Plus



### APPLICATION OF TES IN FOOD INDUSTRY

- Mainly used in canning section
- Used in transportation
- Used in cold storage
- A large part of energy demand met by hot water and steam

### ADVANTAGES

- Increase the shelf life of product
- Reduce the heat loss
- Reduce the cost of processing
- Save storage space

## Lesson 13

## ROLE OF AUTOMATION IN CONSERVATION OF ENERGY IN DAIRY AND FOOD PROCESSING: INCORPORATION OF ENHANCED PLC BASED COMPUTER CONTROLS AND SCADA

### Introduction

- Dairy and other food processing industries adopts many new technologies to improve productivity, use of new automation, manufacture of value-added products and **conservation of energy**
- Dairy and other food processing industry uses high amount of energy in processing, manufacture and storage of various products
- Energy in dairy plants directly refers to the utility's generation and consumption **such as steam, refrigeration, electricity and water**
- **Energy conservation technologies can reduce the total energy consumption of a food process and thus reduces the total cost**
- **A PROGRAMMABLE LOGIC CONTROLLER (PLC)** is an industrial computer
- control system that continuously monitors the state of input devices and makes decisions based upon a custom program to control the state of output devices

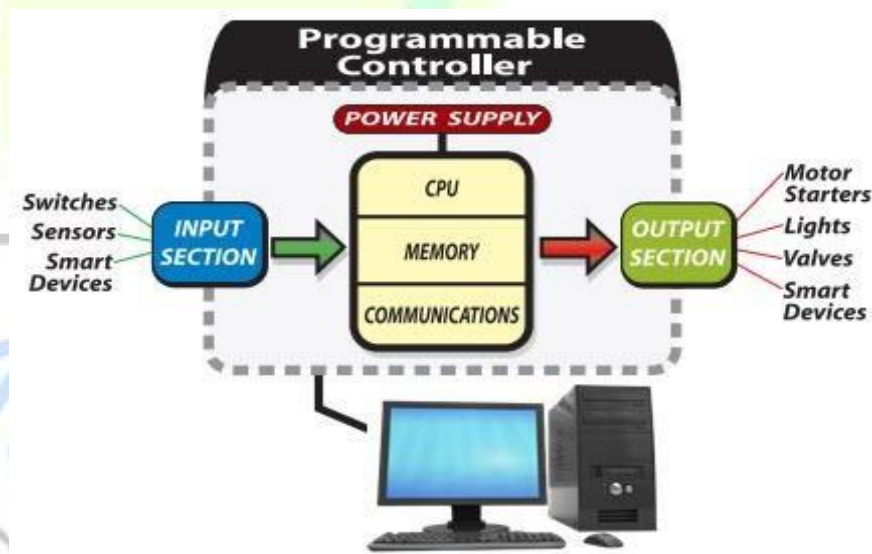

- **PLC**
- Monitors parameter
- Promptly executes the predefined subroutine
- Takes necessary action if any parameter triggers a set point

### Used for

- automation of electromechanical processes
- Long life system Ease of programming
- Microprocessor-based device
- Old concept

### COMPONENTS OF PLC



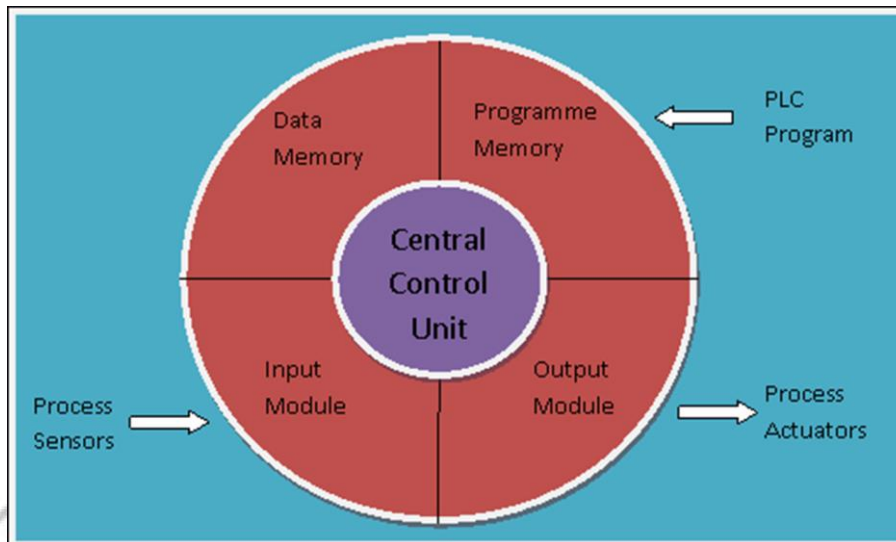

**Advantages**

1. Cost effective for controlling complex systems
2. Flexible and can be reapplied to control other systems quickly and easily
3. Computational abilities allow more sophisticated control
4. Trouble shooting aids make programming easier and reduce downtime
5. Long Life
6. Reduced space
7. Energy saving

**Application of plc in energy conservation**

1. Controlling locally the electricity production in each source
2. Easily guarantee a long-life system
3. Measuring, in a real time base the power consumption and production
4. Reduce the overall unnecessary load on the Utility provider
5. Controlling highly complex systems like Heating, Ventilation and Cooling (HVAC) systems, escalators, firefighting systems etc.

**Different sensors and their functions**

Sensor	Function
Infra Red (IR) Transmitter & Receiver	Monitoring the Entry and/or Exit of a person
Pyro electric Infra Red (PIR) Motion Sensor	Monitoring activity in different portions of the room
Light Dependent resistor (LDR)	Monitoring the lighting conditions of the room
K type Thermocouple	Monitoring the temperature of the room

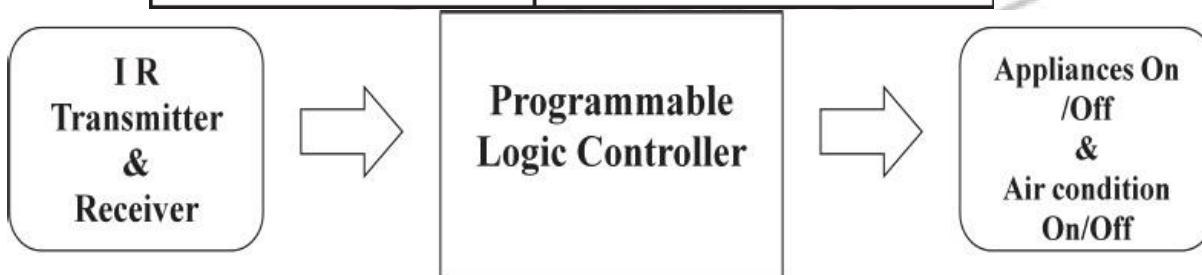

**PLC in food and dairy industry**

1. Provide functions, such as analog monitoring, high speed motion control as well as share data over communication networks

## ENERGY CONSERVATION AND MANAGEMENT

2. Designed to work for multiple inputs and output arrangements
3. Not affected by extreme temperature ranges, electrical noise, and resistance to vibration and impact
4. Inactivation of biological components of food systems ensures a stable quality of food
5. Production of consistent quality goods
6. Flexibility to meet market demands
7. Ensures high and consistent product quality
8. Reduction in production costs
9. Adoption to constantly changing legal demands
10. Ensures manpower savings
11. Increases production
12. Reduces losses

## SCADA

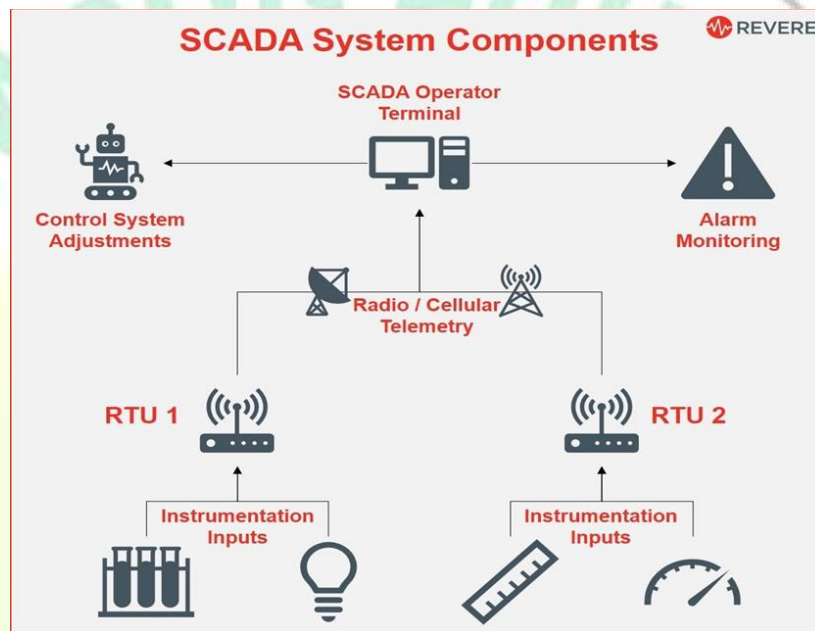

- SCADA consist of hardware and software components
  - Hardware collects and feed data into the computer with SCADA software
  - The data is then processed by the computer before presenting it in a timely manner
  - Typical use of SCADA is data collection and control at supervisory level
  - Supervisory Control and Data Acquisition
  - System that allows an operator to make set point changes from a location central to a widely distributed process.
  - Combines power data and process data (analog and digital)
- Application
- Groups of small hydroelectric generating stations that are turned on and off in response to customer demand usually in remote locations
  - Oils or gas production facilities spread over a large area, require simple controls such as turning motors on and off
  - Pipelines of gas, oil, chemicals, located at varying distance to control opening and closing of valves
  - Irrigation systems

**Elements of SCADA**

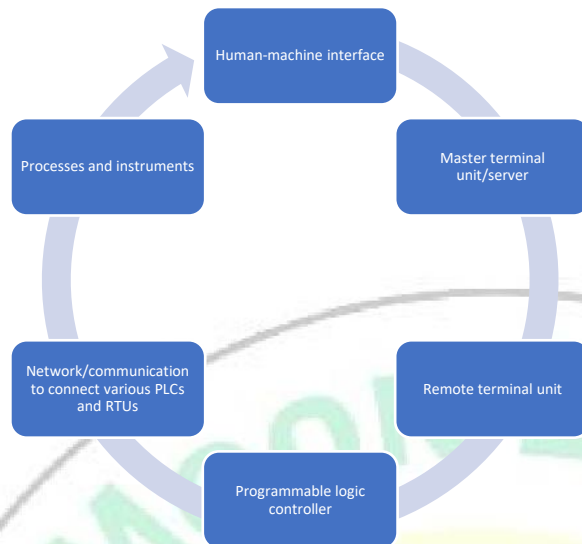

**Some important features of SCADA systems are;**

1. Dynamic process graphic
2. Device connectivity
3. Alarm summary and history
4. Real time trend
5. Security
6. Data base connectivity
7. Recipe management

**SCADA FOR ENERGY MANAGEMENT**

**1. Implementation**

- An intranet/ internet and SCADA system interconnection based on industry accepted communication standards are established
- It employs a wide range of computer and communication technologies- essential parts of energy management system (EMS)

**2. Network programming**

- Enables the program to retrieve information stored in computers located anywhere in the world
- There is ease of access and has low investment as there is no special hardware installation required.

**3. System design**

- The system is based on PLC- Cyborg, which is used to measure consumption of electrical energy, gas, weather and SCADA system for controlling and monitoring
- Web SCADA is web software which provides monitoring and changing variables in real time, storing in database, displaying graphs and alarms and sending reports by email
- In case of an unknown variable, an error occurs, application does not operate in the background, main screen is closed, memory is released and all activity ceases

**4. Read/ write timing**

- All variables of a single page are read with a single command
- When 'OK' is pressed, write will be performed immediately, i.e., value displayed

**Advantages**

1. Collected data of energy sources consumption can be compared on hours, daily, weekly, monthly or yearly basis
2. If there is more than one object, there is no problem adding additional and monitoring consumption comparing to m<sup>2</sup> or per person
3. Deviation in system can be easily found, after detailed analysis



## ENERGY CONSERVATION AND MANAGEMENT

### Role of SCADA in Food Industry

1. Better alarming capabilities- help reduce downtime and product waste
2. Predictive and preventive maintenance- SCADA can collect real- time performance data of all machines in operation, allowing informed decisions to be made.
3. Improved integration- it can provide system flexibility according to production requirements with disparate hardware and systems.
4. Automatic update of temperature set points rather than manual adjustment
5. Control utilities operation- a good fit where products are physically moved and control the movement of power and gas

### CONCLUSION

- SCADA system applications that support strategic energy management include modelling and forecasting, benchmarking, energy use and cost analysis and measurement and verification
- This application can be combined to form powerful information tools that allow organizations to gain a comprehensive understanding of:
  1. Current energy performance
  2. Plan and select cost effective energy conservation measures
  3. Track performance of measures that have been implemented
  4. Verify the saving realized

### References

1. Bureau of Energy Efficiency
2. [www.ktunotes.in](http://www.ktunotes.in)
3. Kay Khaing Hnin, Min Zhang, Arun Mujumdar, Yuelin Zhu; Emerging food drying technologies with energy-saving characteristics: A review; December 2018; Drying Technology 37(12):1-16
4. Taha Hijazi; Non-thermal hybrid drying of fruits and vegetables; Yildiz teknin universitesi
5. <https://www.coolingindia.in/energy-conservation-in-refrigeration-hvac-system/>
6. [http://lrf.fe.uni-lj.si/e\\_sv\\_tehnika/EN/i\\_LightSources.pdf](http://lrf.fe.uni-lj.si/e_sv_tehnika/EN/i_LightSources.pdf)
7. <https://www.ese.iitb.ac.in/~suryad/Lighting-CEP.pdf>